



TSF Fire Equipment

TSF Fire Equipment

Product Spotlight Binder



***“A Service-Disabled, Veteran
Owned Small Business”***





TSF Fire Equipment

TSF Fire Equipment Company

FY20 Equipment Needs Worksheet

Email: TSF@tsfequip.com

Website: www.tsfequip.com

Phone: (813) 434-4900

Toll Free (877) 841-3984



TSF Fire Equipment

Item Description (Product)	Info (X)	Quote (X)	Item Description (Product)	Info (X)	Quote (X)
Firefighter Protective Clothing (Multiple)			Firefighter Gloves (Multiple)		
- Structural Turnout Gear (LION®)			- Structural Firefighter Gloves		
- Proximity Turnout Gear (LION®)			- Proximity Firefighter Gloves		
- Tech Rescue/EMS PPE (LION®)			- Rescue / Extrication Gloves		
- Wildland Clothing PPE (Multiple)			- Nomex (Flyers) Gloves		
- Coveralls (FR, Nomex or otherwise)			- Wildland / Work Gloves		
- PPE Extractor/Dryer Equipment			- Glove Straps		
- Navy2K Firefighting-Coverall Gear			- EMS/Medical/BBP, other Gloves		
Firefighter Uniforms / Station Wear (Multiple)			Firefighter Protective Hoods (Multiple)		
- NFPA Compliant ABU'S (Closeout)			- Particulate Resistant Hoods		
- Firefighter Uniform Shirts (Multiple)			- Firefighter Nomex Hoods		
- Firefighter Uniform Trouser (Multiple)			- Firefighter Hoods (Designs)		
- Firefighter Uniform Shorts (Multiple)			Chemical/Biological/Radiological/Nuclear (Multiple)		
- Firefighter Undergarments (Multiple)			- LION Extended Response Suit (ERS)		
- Firefighter Thermal Wear (Multiple)			- LION MT94 (Multi-Threat)		
- Firefighter Jackets/Coats (Multiple)			- CBRN Masks (Avon)		
Firefighter Helmets (Multiple)			- CBRN Gloves/Liners		
- Structural Helmets (Traditional)			- CBRN Boots/Liners		
- Structural Helmets (Modern)			- Decon Bag (True North)		
- Structural Helmets (Leather)			Firefighter HAZMAT PPE (Multiple)		
- Proximity Helmets (LION)			- Level-A Entry Suits		
- USAR/Confined Space Helmets			- Level-B Entry/Decon Suits		
- Eye Protection (ESS Goggles)			- Tyvek Disposable Suits		
- Eye Protection (4", 6" Face Shields)			- Flash Fire Entry HazMat Suits		
- Helmet Fronts/Shields (multiple)			- Kappler Chem Tape (Suit Tape)		
- Helmet Accessories (Decals, etc)			- HazMat Suit Testing Equipment		
Firefighter Boots (Multiple)			Firefighter/EMS Ballistic Protection (Covert Armor***)		
- Tri/Quad certified Fire Boots			- Fire/EMS Body Armor (Carrier Vest)		
- Dual-certified Fire Boots			- Light Duty Concealment Carriers		
- Structural Boots			- Ballistic Armor Panels (Level IIIA)		
- Wildland Firefighter Boots			- Rifle Plates (High-Threat, III, III+ IV)		
- USAR / Tactical Boots			- Ballistic Helmets (Level IIIA)		
- Station Wear /Uniform (Boots)			- Pouches, Pockets, IFAKs, etc.		
NFPA 1851 PPE Cleaning/Insp/Mx/Repair Program			- Carrying Cases/Bags for Armor		
- LION Stay Safe (New Purchases)			- Ballistic Shields, Blankets		
- LION Total Care (Any/All – NFPA 1851)			- NFPA 3000 ASHER Product Info		

Firefighter Training Eqpt (LION, formerly BullEx)			Firefighter Gear Bags and Cases (Multiple)		
- LION Attack™ Digital Fire Training			- Wheeled Firefighter Gear Bags		
- LION HLTS Live Fire Training System			- EMS/Medical Equipment Bags/Kits		
• 19 Modular Props to Use With			- Hard Case Storage/Trans (Explorer)		
- LION Magnum Enhanced Trng Sys			- Lightning X Gear Bags (PPE/SCBA/etc.)		
- LION Bullseye™ Digital Training			Firefighting Ladders (Multiple)		
- LION ITS/ITS Extreme™ Fire Training			- Ground, Extension and Attic/MP		
- LION R.A.C.E Station (Pub Training)			- Ladder Light™ Illumination		
- Fire Safety Trailers / SmartProps			- Ladder LockDown™		
• Smartstove™, Trashcan/ Micro			Powered Rescue/Vent Equipment (Multiple)		
- SmartDummy™, & Thermal Mannequin			- Mechanical/Powered/Battery/Air (We Have All!)		
- Smoke Machines / Fluid			- Spreaders, Cutters, Combos, RAMS, Struts, Breaching, Bags (High or Low Pressure) Ventilation (PPV or Extract), Confined Space, Saws (Rescue/Chain/etc)		
- Custom Builds (Containers/ARFF)			- Lighting Equipment/Systems		
Fire Hose (Multiple)			- Tech Equip (USAR/CSR/Collapse)		
- Fire Attack Hose (1"-3")			- Thermal Imaging Camera (TIC)		
- Supply Line (2 ½" – 4" Hose)			Firefighting / Rescue Hand Tools		
- Large Diameter Hose (LDH)			Striking, Prying, Cutting, Spreading (We've got 'em)		
- Wildland/Forestry/Booster Reel			Hydrant Wrenches/Spanners		
- Hard Suction Hose / Strainers			Wildland Fire Tools, Axes, Hammers, Cribbing/Stabilization		
- Hose Cleaning/Drying/Storage Eqpt			Technical Rope Rescue Equipment		
- Hose Testing Equipment			- ALL (Including Water Rescue)		
Fire Pumps (CET Pumps)			Vehicle Mounted Equipment (Multiple)		
- Floating Fire Pumps (<= 360 gpm)			- IMMI™ SmartDock SCBA Bracket		
- Large Fire Pumps (stationary)			- IMMI™ ReadyReach Seatbelt		
- SKID mounted Fire Pumps			- EZ Spanner™ Mounting Sys		
Water Management (Multiple)			- Compartment Storage Sys (PAC Tools)		
- Portable Water Tanks (EWS)			Incident Command/Mgmt Systems (Multiple)		
- LDH Gated Manifolds			- Command Vests / Signs		
- Floating or LDH Strainers			- IC Boards, Pads and Documents		
- Intake Relief Valves (Vehicles)			- Accountability Systems		
- Hydrant and/or Vehicle Couplings			HazMat Response Equipment (Multiple)		
- Clamp Systems (H2O)			- Showers, Hoses, Pools, Manifolds,		
Firefighting Nozzles & Appliances (Multiple)			- Tarps, Grates (elevated), Benches		
- Handline Nozzles (Adjustable)			- Vacuums (HEPA), Brushes, Wands		
- Handline Attack Tips (Smooth)			- Decon Solution, Sprayers, Bladders,		
- Portable Monitors (Lg GPM)			- Containment (OverPacks, etc.)		
- Removeable Monitors (Vehicles)			Small Equipment (Multiple)		
- Deck Guns			- SOG® Knives/Multi-Tools		
- Gated Siamese & Wyes			- Flashlights / Illumination (MN8)		
- Coupling Reducers			Facility Equipment (Multiple)		
- Hose Straps			Ready Rack® PPE Storage Systems		
- High-Rise / RIT Packs			Eye Wash Stations, Decon/Safety		
- High-Rise (Hotel) Straps					
Firefighting Agent (Multiple)					
- Portable Fire Extinguishers					
- Wheeled Fire Extinguishers					
- Extinguisher Maintenance (Parts)					

WHERE THERE'S SMOKE... THERE ARE SOLUTIONS.



CALL 1.800.421.2926



CONTAMINANT CONTROL

YOU'RE NOW ENTERING THE

REDZONE™

Contaminant Control Package

When you arrive on the scene of a fire, your personal protective equipment (PPE) is immediately exposed to a number of toxic chemicals – exposure that can result in serious health problems. That includes cancer, which is currently the leading cause of U.S. firefighter deaths. With that fact in mind, LION has developed **RedZone™**, our exclusive, **NFPA 1971-certified** contaminant control package.

Developed in partnership with the **U.S. Department of Homeland Security (DHS)** and **North Carolina State University's Textile Protection and Comfort Center**, RedZone features five particulate-blocking zones designed to help reduce your exposure to the dangers lurking in fireground smoke, keeping you ready for action.

ZONE 1: **PARTICULATE-BLOCKING HOOD**

A breathable, ultra-soft hood with **StedAir® PREVENT** protects the head and neck from particulates, while also providing excellent mobility and unrestricted hearing during firefighting activities.

ZONE 2: **ARM GUARD**

Elasticized wrist shields and enhanced **IsoDri®** knit wristlets with **Nomex® Nano Flex** help block particulates at the coat-to-glove interface.

ZONE 3: **CORE GUARD**

A **Nomex® Nano** multi-layered composite with an elasticized band helps reduce particulate ingress at the coat-to-pant interface.

ZONE 4: **CLOSURE GUARD**

Engages with just one zip. No extra steps to don the gear. Red hook and loop indicates when turnout coat is properly closed.

ZONE 5: **LEG GUARD**

Together, the elasticized ankle shield and **Nomex® Nano Flex** calf protector help block particulate exposure at the pant-to-boot interface.

featuring

DuPont™
Nomex. Nano

DuPont™
Nomex Nano Flex

StedAIR®
PREVENT



CONTAMINANT CONTROL



Particulate-Blocking Hood

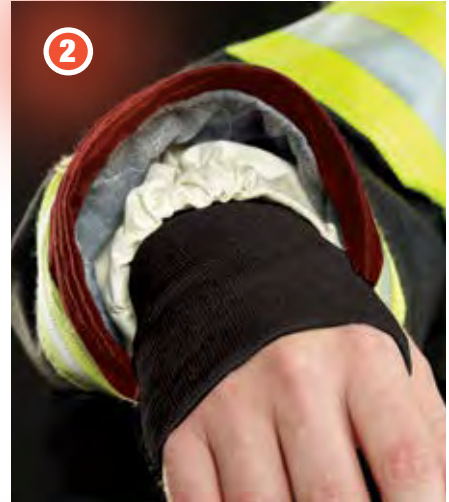

Arm Guard



Closure Guard



Leg Guard (Interior Detail)

OTHER CONTAMINANT CONTROL NETWORK OFFERINGS

See pages 40 and 41 for more details about LION TotalCare PPE maintenance services and state-of-the-art fire training products.



LION TotalCare PPE Decon & Ozone Cleaning



LION Digital Fire Training Tools

CONTAMINANT CONTROL

YOU'RE NOW ENTERING THE

REDZONE™

Particulate-Blocking Hood

featuring

StedAIR®
PREVENT

FEATURES & BENEFITS

- ▶ Certified to meet NFPA 1971, 2018 Edition optional particulate-blocking hood requirements
- ▶ Total particulate protection throughout
- ▶ Air-permeable to help manage core temperature and heat stress
- ▶ Streamlined, two-layer construction for easy movement, flexibility and unobstructed hearing
- ▶ Extended bib design provides optimal shoulder and neck coverage that stays in place
- ▶ Ultra-soft, flame-resistant (FR) material for maximum comfort and fire protection
- ▶ Extreme durability that maintains its particulate-blocking effectiveness even after 100 washes
- ▶ Universal sizing that comfortably fits all heads

AVAILABLE IN TWO
COLOR COMBINATIONS

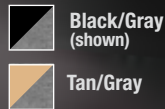

Streamlined, Two-Layer
Construction

Durable Flatlock
Nomex® Thread
Stitching



Extended, Full-Coverage
Bib Design

INSIDE LAYER:
STEDAIR® PREVENT
PARTICULATE BLOCKER

OUTSIDE LAYER:
KERMEL/VISCOSE 9 OZ.
INTERLOCK KNIT

VISIT LIONPROTECTS.COM



Cutting Edge Turnout Gear That
Combines Combat and Sports Technology
For Outstanding Performance & Fit

V-FORCE[®]



LION[®]
ready for action

A Cut Above The Rest

LION's V-Force turnout gear features an innovative **cut-in-motion design** for a more ergonomic garment that moves the way you do, while still offering unparalleled protection. Professional sport and military technology combine to create turnout gear that provides the mobility and comfort to do your job every day with the toughness and durability you expect from LION. V-Force comes standard with LION's patented **IsoDri® Moisture Management System**. IsoDri turnouts absorb less water, helping protect against compression burns, while keeping gear drier and lighter during use. In wet conditions, LION IsoDri gear remains more breathable and comfortable, reducing fatigue and heat stress. It also dries faster between runs.

Key V-Force Comfort & Mobility Benefits & Features

V-Force Turnout Coats

COMFORT COLLAR

Ergonomically shaped to improve comfort, interface better with other PPE elements and deliver continuous thermal and moisture protection.

V-FIT™ ELBOWS

Elbows include cutouts, shaped pieces and darts to allow natural arm movement without restrictions or tugging.

SUPERIOR CUT

Cut-in-motion design includes contoured coat sides, for a fit that moves with your body during firefighting activities. This innovative cut evenly distributes the weight of your turnout and positions seams to reduce conflicts with SCBA straps that can cause irritation and discomfort.

RAGLAN SLEEVES

Shaped like your arm to promote free, unrestricted movement and reduce turnout coat hem rise.

OPTIONAL BI-SWING BACK

Features inverted pleats in both the outer shell and liner system that expand as your arms move forward. The result is no tugging, binding or bunching of material.

LION VENTILATED TRIM™

Provides a conduit for the release of vapor and guards against the potential hazards of trapped moisture. It's also more flexible than traditional reflective trim.

Cutting Edge Turnout Gear That Combines Combat and Sports Technology
For Outstanding Performance & Fit



V-Fit
Contoured
Sides



Contoured
Raglan Sleeves



Cutting Edge Turnout Gear That Combines Combat and Sports Technology
For Outstanding Performance & Fit



COMFORT & MOBILITY



Radial
inseam &
Banded Crotch

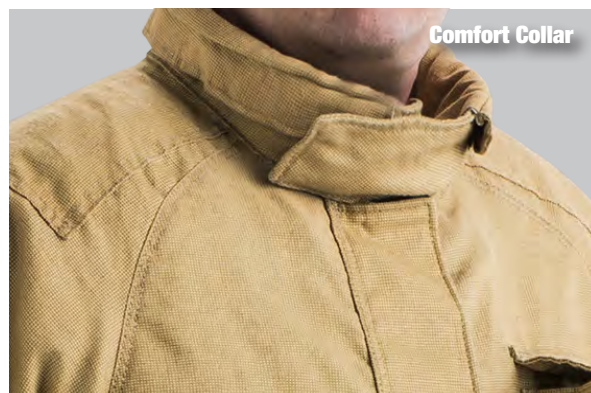

Comfort Collar



V-Fit Legs
& Knees



V-Fit
Elbows



Streamlined
Storm Flap



Optional
Bi-Swing Back

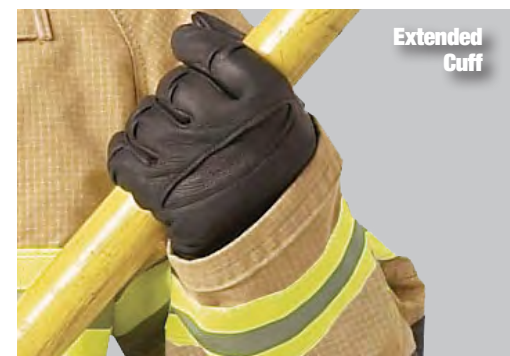

Extended
Cuff



V-Force® Turnout Pants

LION V-Force pants are available in multiple styles to fit various body types and meet your comfort needs, without sacrificing mobility, durability, or safety. Individuals can choose from a variety of styles within a department and all will still be uniform.

All V-Force Pant Designs feature the following:

- V-Fit™ legs and knees are contoured and feature cutouts, shaped pieces and darts to enable free, easy movement (optional additional knee padding available)
- Radial Inseam and banded crotch reduce tension to add comfort and increase wear life of your pants
- Nine inches of SemperDri™ in the lower legs repel water to keep your pants dry and reduce working weight, also reducing firefighter heat stress

V-FORCE BELTED PANTS

V-force belted pants offer a low-rise waist with belt loops; a two-inch Kevlar® belt with a quick-release, thermoplastic buckle and suspender buttons to give you the option of using the belt alone or adding suspenders.



V-FORCE ULTRA LOW-RISE PANTS

The V-Force Ultra Low-Rise Pant features a reduced front rise, which sits comfortably on the hips like a pair of jeans, without sacrificing thermal protection. The widened crotch gusset allows enhanced mobility and the waist height reduces bunching and wear and tear from wearing pants too low.



V-FORCE LUMBAR PANTS

V-Force Lumbar Pants have a traditional waist and feature the LION Lumbar Support System. This system is integrated into the V-Force pant and is orthopedically designed to provide adjustable mechanical support when you're lifting, bending forward, standing or performing emergency rescues.



V-FORCE HIGH-BACK PANTS

V-Force High-Back Pants provide the ultimate in thermal protection. A five-inch back panel extends above the waist. A unique hook and loop support pad attaches LION's V-Back™ Suspenders to the pants. Snap tabs fasten the suspenders to the front (V-Back™ High-Back Suspenders are required).

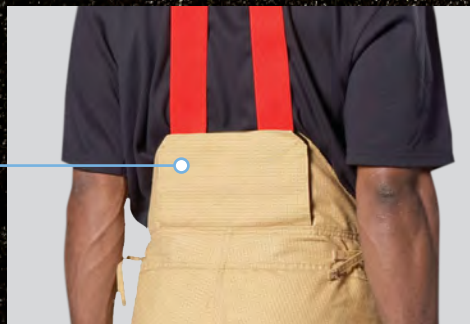



CUTTING EDGE

Natural

Black

COMFORT COLLAR

STREAMLINED
STORM FLAP

LION
VENTILATED TRIM™

V-FIT ELBOW

EVER-DRY™ REACH
SYSTEM WITH
WRIST SHIELD SYSTEM™

RADIAL
INSEAM

V-FIT KNEE

SEMPER DRI™
SYSTEM

■ Standard Features

A variety of materials, pockets,
and accessory options are available

For more information about LION V-Force, contact your
LION sales representative or visit us online at www.lionprotects.com



LION®
ready for action

LION V-Force, V-Fit, V-Back, Ventilated Trim, SemperDri, and IsoDri Moisture Management System,
are trademarks of LION. Kevlar is a tradename of E.I. du Pont de Nemours and Company.

SUPER-DELUXE®

LION Super-Deluxe gear features our patented **Freedom® Design**, which reduces firefighter body stress through a series of innovative, ergonomic features that help deliver exceptional mobility and comfort.



What you see here ▶▶

A. COMFORT COLLAR

Comfort collar and optional throat tab deliver continuous thermal and moisture protection while providing exceptional interface to SCBA mask

B. FREEDOM™ ELBOWS

Enable the arm to bend freely while keeping the wrists protected by reducing sleeve travel

C. FREEDOM™ KNEES

Provide gussets that the knee can fit into when crawling, climbing, bending and kneeling, resulting in unrestricted movement

D. STREAMLINED STORM FLAP

Reduces thermal build up, bulk and working weight

E. HOOK & DEE RING CLOSURES (OPTIONAL)

Includes a hook and loop closure strip under the storm flap

F. OVER-THE-HAND WRISTLETS

8" KEVLAR®/ Spandex® thumb hole knit wristlets that provide added thermal hand protection and stay securely in place

G. EVER-DRY™ REACH SYSTEM

A unique attachment system allows turnout sleeve wristlets and the moisture barrier to move with your wrist when your arms are outstretched, minimizing exposure to water, steam and flame.

H. LEATHER REINFORCEMENTS

Reinforced knees, cuffs, kick shields, shoulders and elbows offer added thermal protection and extended wear life.

I. LION VENTILATED TRIM™

Provides a conduit for the release of vapor and guards against the potential hazards of trapped moisture.

CUSTOMIZABLE!

SUPER-DELUXE TURNOUTS PROVIDE CUSTOM SIZING AND ARE AVAILABLE IN A VARIETY OF MATERIAL COMBINATIONS WITH YOUR CHOICE OF ADDITIONAL GEAR OPTIONS.



Kevlar | Nomex

SUPER-DELUXE® DETAILS



A. Comfort Collar

Ergonomically-shaped to improve comfort, interface better with other PPE elements and deliver continuous thermal and moisture protection. An optional throat tab is available.

B. Underarm Bellows Sleeves

Arm bellows compress and expand to reduce hem rise and sleeve travel, resulting in added protection.

C. Drag Rescue Device (DRD)

Extremely durable and easy-to-access, yet designed to be unobtrusive and out of your way. The only time you'll feel it is when it's deployed.

D. Ever-Dry™ Reach System

Reduces vulnerability to water, steam and flame. When you reach, full protection stays on your wrist.

E. Thermoplastic Zipper Closure

Thermoplastic zipper coat and pants closure

with hook and loop. Pants also have a snap storm fly closure.

F. Reinforcements

Reinforced knees, cuffs, kick shields, shoulders and elbows for thermal protection and added wear life.

G. Ventilated Trim™

Provides a conduit for the release of vapor and guards against the potential hazards of trapped moisture.

H. Breathable Moisture Barrier Closures

Storm flap, waterwells and fly facing are all lined with breathable moisture barrier material for dryness and protection.

I. Zip-In Coat Liner

Coat liner zips into outer shell for reliable attachment, reduced bulk and outstanding comfort.

J. Semper Dri™

Reduces water absorption in pants

legs, coat cuffs and yoke to keep your working weight lighter.

K. Lite-N-Dri™ Knees

Knees with water-resistant FR Lite-N-Dri cushioning between the moisture barrier and thermal liner to enhance thermal protection. Includes another layer of Lite-N-Dri between the outer shell and the knee reinforcement.

L. Adjustable Fit Take-Up Straps

Pants have waistband and external take-up straps for a comfortable fit.

M. Liner Inspection System

Opening allows you to easily examine film side of moisture barrier and inside of thermal liner. Makes Complete Liner Inspections easier and faster.

N. Yoke Extra Thermal Protection

Yoke of coat employs Semper Dri™ System to reduce water absorption and enhance thermal protection.



A firefighter in full gear, including a yellow helmet and tan turnout coat with reflective stripes, is using a hydraulic rescue tool (Jaws of Life) on a red car. The scene is outdoors on a paved surface, with a fire truck visible in the background under a clear blue sky.

MULTI-PURPOSE RESCUE WEAR FOR EXTRICATION, EMS & WILDLAND



CALL 1.800.421.2926

3M Scotchlite
Reflective Material



USAR/TECH RESCUE

VersaPro® Rescue Wear

LION created the VersaPro and VersaPro Plus to meet the wide variety of situations that first responders encounter. This dual-certified NFPA 1951 Utility/1977 Wildland garment is perfect for extrication, technical rescue and scene investigation. It offers more protection than a station uniform, but it's less cumbersome than structural turnouts. It can also help reduce wear and tear on your turnout gear.

VersaPro features include:

- Extremely durable, yet very comfortable Sigma™ fabric
- A bi-swing back for added mobility and comfort
- Radio and cargo pockets offer the space to keep you prepared
- Lite-N-Dri™ knee cushioning offers additional padding and knee protection

In addition to all the same great features as Versa Pro, Versa Pro Plus offers:

- Additional Hi-visibility trim
- PCA elbow and knee reinforcements
- Two layers of Lite-N-Dri knee padding
- A flashlight strap

TR51™ Rescue Wear

The LION TR51 is an extremely versatile technical rescue garment. Certified to meet NFPA 1999 as well as 1951 Rescue and Recovery, you can use it for both EMS duty and technical rescue tasks. The TR51 is offered in various outer shells for tough and durable extended wear life. The CROSSTECH® SR removable barrier provides liquid penetration resistance to water, blood, and bodily fluids. This barrier can also be removed for technical rescue utility scenarios.

Other TR51 features include:

- Technical Rescue NFPA 1951 and EMS NFPA 1999 certification
- Ergonomic-design for optimal rescue and recovery performance
- 3M™ Scotchlite™ Reflective Material makes sure you're seen in low-light and daylight conditions
- Adjustable coat and pant features for a more personalized fit
- Durable, high-quality construction
- Additionally, there are plenty of task-specific pockets for the tools of the trade
- Available in male and female models



MEDICAL RESPONSE

MedPro™ Emergency Medical Rescue Wear

Designed specifically to meet the demanding needs of today's EMS professionals, LION's MedPro EMS coat and pant combination features advanced construction and optional enhancements that ensure on-the-job comfort, safety and mobility.

MedPro features include:

- NFPA 1999-certified for advanced protection (Also available in Hi-Vis Yellow certified to meet ANSI 107)
- High-performance, Westex® DH fire-resistant outer shell with a Hydropel Premier finish for comfortable, durable protection against flash fires
- CROSSTECH® EMS moisture barrier protects against blood, bodily fluids and water, while remaining breathable

- Superior mobility thanks to a banded crotch, a bi-swing back and underarm bellows
- PCA-reinforced elbows and knees with Lite-N-Dri cushioning for added durability
- Numeric sizing, take-up straps and zippered legs for a custom fit that's easy to don and doff
- Available in male and female models

MedPro also offers the following options:

- A detachable lined hood for additional head protection
- Self-fabric cuffs, knees and elbows
- Belt and belt loops or suspenders offer a secure, comfortable custom fit
- A removable winter liner provides added protection against cold temperatures
- Custom lettering for department and personal identification

MedPro™
Hi-Vis Yellow



MedPro™
Navy

INTRODUCING FIRE BOOTS THAT DON'T QUIT UNTIL YOU DO

GORE
CROSSTECH

Propper



CALL 1.800.421.2926

GORE®
CROSSTECH®
PRODUCTS

FIRE & EMS BOOTS

INTRODUCING:

LION Fire Boots by Thorogood®

From structural fire to wildland to EMS responses, LION has teamed up with Thorogood to provide you with high-performance, high-quality fire boots that keep you ready for action and don't quit until you do.

KnockDown Elite 14" Leather Structural Fire

Featuring our exclusive Vibram® Fire & Ice All-Terrain sole, these waterproof, cut-resistant leather upper boots go on with ease and hold you firmly in place until you use the handy heel kick plate to take them off. They also include a removable dual-density polyurethane insole.

QR14 14" Leather Structural Fire

Our slip-resistant QR14 boots are built for comfort, durability and safety. The flex gussets allow the boot to move with you. 3M™ Scotchlite™ Hi-Vis piping in these waterproof, flame- and cut-resisting leather boots creates a high-visibility look when exposed to direct light.

U.S.A. Oblique 14" Leather Structural Fire

These made in the U.S.A. leather structural fire boots offer a roomier, more comfortable oblique toe. The waterproof, breathable membrane keeps dangerous fluids out when you waded into hazardous situations. The Aztec lining wicks away moisture, while the removable contoured

cushion insole maintains comfort no matter how long you're on your feet.

HellFire 14" Rubber Fire Boot Series

These waterproof, heat-resisting, and shock absorbing rubber boots feature a lug sole and stainless steel, puncture-resisting bottom plate. They also include an oversized steel toe and durable Vulcanized construction. They're available in two options:

KEVLAR-INSULATED

A Kevlar® yellow knit one-piece liner that's five times stronger than steel.

FELT-INSULATED

A 3.5mm polyester needled felt liner with heel reinforcement.

Station 1 9" EMS/Wildland Fire

With their exclusive Vibram® All-Terrain Sole and GORE® CROSSTECH® moisture barrier, these boots provide exceptional traction and waterproofing. Safety features also include cut-resistant leather, a flexible Lenzi L-Protection® puncture-resistant insole, a steel triple-rib ladder shank and a composite safety toe.

QR14

KnockDown Elite

U.S.A. Oblique

HellFire (Felt-Insulated)

HellFire (Kevlar-Insulated)

Station 1





HELMETS MAXIMIZING SAFETY, FIT & FUNCTION



CALL 1.800.421.2926

DU PONT
Kevlar. | Nomex.

3M Scotchlite[®]
Reflective Material



LEATHER HELMET

American Heritage™

This traditional fire helmet combines time-honored styling and craftsmanship with state-of-the-art advancements in design, leather tanning and composites. The result is a low-profile leather helmet that is attractive, durable and comfortable.

EXCLUSIVE FEATURES

Leather Shell

State-of-the-art chromium tanning process to seal protective qualities and color and to deflect heat. Won't chip or bubble like painted leather helmets.

LeatherGlas™ One-Piece Construction

Process bonds fiberglass composite between the outer and inner layers of the leather shell for superior strength and durability during extreme conditions.

Suspension

Patented Center of Gravity™ adjustment system lets you set the center of gravity to your liking and keeps it positioned in place.

Height Adjusters

Provide three different headband height positions.

Ratcheting Headband

Adjusts from size 5½ to 8¾. Headband is cushioned with foam and covered with leather for comfort and secure fit.

Eye Protection

Choose from three options:

- High-Temperature 4" APEC Faceshield (with thumbwheel adjustments)
- ESS Goggles
- Flip-Downs with Goggles (can be purchased without goggles, but will not be NFPA-compliant)

Edge Binding

Aluminum core edge binding is durable, but light.

Chin Strap

Easy-to-adjust, quick-release chin strap with postman's slide.

Ear & Neck Protection

Black DuPont™ Nomex® brand fiber/flannel ear covers for added neck/ear protection. Other materials/colors available upon request as replacement parts.

Shield Holder

Hand-carved brass eagle leather shield holder.

Added Visibility

3M™ Scotchlite™ Reflective Material (2" x 2½" lime-yellow trapezoids) offers excellent heat resistance and maintains brightness and color after heat exposure.

Shell Colors

Available in Yellow, Black, White, Red, Blue, Orange or Natural.



FIBERGLASS HELMETS

American Legend™ Fire Helmet Series

These lightweight, traditional fiberglass fire helmets provide outstanding head, eye, ear and neck protection, while also offering additional head room for on-the-job comfort and mobility.

Weight

American Legend: 59 oz.
American Legend X:
53 to 59* oz.

Durable Fiberglass Shell

Sheet moulding composite (SMC) fiberglass shell features a powder coat, impact-resistant finish

Suspension

Patented Center of Gravity™ adjustment system lets you set the center of gravity to your liking and keeps it positioned in place. The suspension system is removable for easy inspection, cleaning or maintenance.

Height Adjusters

Provide three different headband height positions.

Ratcheting Headband

The American Legend adjusts from 5.5 to 9, while the American Legend X adjusts from 5.5 to 9.5. Headband is cushioned with foam and covered with black knit DuPont™ Nomex® brand fiber for comfort and secure fit. Other materials available upon request.

Eye Protection

American Legend: Retractable eye guard
American Legend X: Faceshield, flip-downs, goggles or goggles and flip-downs

Edge Binding

Aluminum core edge binding is durable, but light.



American
Legend

Chin Strap

Easy-to-adjust, quick-release chin strap with postman's slide.

Ear & Neck Protection

Black DuPont™ Nomex® brand fiber/flannel ear covers for added neck/ear protection. Other materials/colors available upon request as replacement parts.

Shield Holder

Hand-carved brass eagle leather shield holder.

Added Visibility

3M™ Scotchlite™ Reflective Material (2" x 2½" lime-yellow trapezoids) offers excellent heat resistance and maintains brightness and color after heat exposure.

American
Legend X

Shell Colors

Available in Yellow, Black, White, or Red.

* Weight varies depending on configuration



CALL 1.800.421.2926

•DUPONT•
Kevlar | Nomex

3M Scotchlite™
Reflective Material

FIBERGLASS HELMETS

American Classic™ & Legacy™ 5

LION's American Classic™ and Legacy™ 5 durable fiberglass helmets balance safety and comfort, while also giving you a choice of Traditional or Modern style.

Durable Shell

Fiberglass shell employs exclusive patented TherMax™ composite technology to ensure thermal protection and structural integrity of the entire shell. RTM molding provides color pigmentation throughout for lasting good looks.

Ratcheting Headband

Adjusts from size 5½ to 8¾. Headband is cushioned with foam and covered with black knit DuPont™ Nomex® fiber for comfort and secure fit. Other materials available upon request.

Suspension

Patented Center of Gravity™ adjustment system lets you set the center of gravity to your liking and keeps it positioned in place. The suspension system is removable for easy inspection, cleaning or maintenance.

Height Adjusters

Provide three different headband height positions.

Eye Protection

Choose from two options:

- High temperature 4" APEC Faceshield
- ESS Goggles

Ear & Neck Protection

DuPont™ Nomex fiber/flannel covers. The American Classic standard cover color is Black and the Legacy 5's standard cover is Yellow. Other cover

materials/colors are available upon request.

Chin Strap

Easy-to-adjust, quick-release chin strap with postman's slide.

Edge Binding

Aluminum core edge binding is durable, but light.

Shell Colors

Available in Yellow, Black, White, Red, Blue, Orange or Green. Custom colors available upon request with a minimum order of 50 helmets.

AMERICAN CLASSIC

Style: Traditional

Eye Protection

In addition to faceshield or goggles, flip-downs with goggles is an additional American Classic option. Flip-downs can be purchased without goggles, but will not be NFPA compliant.

Added Thermal Protection

Additional thermal protection is provided by the American Classic's removable thermal insulator and thermoplastic liner.

Added Visibility

3M™ Scotchlite™ Reflective Material (2" x 2½" lime-yellow trapezoids)

Shield Holder

Hand-carved brass eagle leather shield holder.

LEGACY 5

Style: Modern, Low-Profile

Impact Cap

Lexan®/ABS dome encapsulated with urethane foam for outstanding thermal resistance.

Added Visibility

3M™ Scotchlite™ Reflective Material (1" x 4" lime-yellow bars)





CROSSTECH
Glove Institute

LION
PRIMUS™

LION
PRIMUS™

FIRE & WORK GLOVES KEEPING YOUR HANDS IN GEAR



CALL 1.800.421.2926

DUPONT

Kevlar | Nomex

GORE®
CROSSTECH®

PRODUCTS

STRUCTURAL FIRE



PRIMUS® 3D Structural Fire Glove

- State-of the art 3D design provides maximum dexterity and comfort with fingertip control, flexibility and grip
- Heat-resistant, flexible and durable leather outer shell provides protection against thermal assaults, cuts and sharp objects
- CROSSTECH® insert and Kovenex® lining offer lightweight, flexible, and comfortable liquid and thermal protection
- Sewn-in liner stays easy to don and doff, and won't pull out while doffing – even when wet
- Lite-N-Dri™ back-of-hand knuckle pad increases thermal and impact protection in high-heat, high-abrasion areas
- Enhanced gauntlet cuff for greater comfort and quicker donning and doffing
- Color: Black/Gray
- Sizes: 2XS - 4XL, Regular & Cadet

Commander™ ACE Gunn Cut Structural Fire Glove

- Enhanced gunn-cut pattern provides increased comfort and better wear
- 100% Eversoft side-split cowhide leather shell provides outstanding, long-lasting water repellency, superior softness and peak thermal insulation performance in high-heat conditions
- Breathable in wet conditions and stays soft and stays pliable when air-dried
- CROSSTECH Insert glove moisture barrier for better flexibility, less bulk in the palm and improved dexterity
- Lite-N-Dri back-of-hand padding for advanced thermal protection
- Shorter leather gauntlet cuff with better interface for easier donning and doffing
- Color: Black
- Sizes: 2XS - 4XL, Regular & Cadet

Commander™ Gunn Cut Structural Fire Glove

- Enhanced gunn-cut pattern provides increased comfort and better wear
- 100% Eversoft side-split cowhide leather shell provides outstanding, long-lasting water repellency, superior softness and peak thermal insulation performance in high-heat conditions
- Breathable in wet conditions and stays soft and pliable when air-dried
- CROSSTECH Insert glove moisture barrier for better flexibility, less bulk in the palm and improved dexterity
- Kevlar® wristlet or leather gauntlet cuff
- Colors: Gold/Black
- Sizes: 2XS - 4XL, Regular & Cadet



TAKING PROTECTIVE SOLUTIONS TO ANOTHER LEVEL.



CHEM-BIO & UNIFORMS

CBRN

Chem-Bio incidents don't have to mean hot and muggy disposable suits. LION CBRN offers several NFPA-certified chem-bio ensembles to provide mission-specific protection. Each is lightweight and comfortable, and can be reused as long as you're not exposed or contaminated.

MT94™

Delivers NFPA 1994 Class 2 vapor, liquid and FR protection for chem-bio incidents (TICs, TIMs and CWAs). Certified to meet NFPA 1994 Class 2 and NFPA 1992 requirements. Available in front and rear entry configurations.

ERS™

The Extended Response Suit (ERS) is designed for protection against NFPA 1994, Class 3 vapor and liquid challenges (TICs, TIMs and CWAs). Certified to meet NFPA 1994 Class 3 and NFPA 1992.

Commando®

This chem-bio under-layer garment for "warm zone" operations is certified to NFPA 1994, Class 3 requirements. Easily integrates with a variety of equipment and outer garments. The Commando delivers exceptional mobility and comfort in demanding situations.

StationWear™

Durable, high-quality uniforms designed especially for first responders

Identity & Performance

Your appearance must communicate authority and professionalism. That's why LION StationWear is available in deep, rich navy; vibrant medium blue and crisp white. LION's station uniforms are engineered for easy care and maintenance.

Your job is unpredictable and requires a uniform with the strength and performance to stand up to the rigors of the job.

With LION StationWear you get:

- Designs with features that facilitate job performance
- Uniform pants and shirts that are available in female as well as men's cuts
- Construction that meet the challenges of your job head-on
- Wicking fabrics that transport sweat away from the body and toward the bunker gear's breathable moisture barrier

NFPA 1975-Compliant

The underlying purpose of NFPA 1975 is "to provide uniforms that will not contribute to burn injury severity". Our NFPA 1975-compliant uniforms are made with fabrics, pocketing, labels, waistbands, zipper tape and sewn with thread all certified to meet this requirement.



CALL 1.800.421.2926

GORE™ CHEMPAK™
PRODUCTS

3M Scotchlite™
Reflective Material

DuPont™
Nomex.



PPE MAINTENANCE



LION TOTALCARE® Keeping You Safer, Longer

Turnouts and other PPE represent a major investment for your department. With dwindling budget dollars, you want maximum return out of your investment, while maintaining optimum levels of safety.

LION TotalCare, a leader in PPE maintenance and repair, can help save you money and keep your gear safer, longer.

Part of our **Contaminant Control Network** of products and services, TotalCare is a NFPA 1851-verified ISP

recognized by all PPE manufacturers. TotalCare provides professional maintenance services that help enhance firefighter safety, extend the life of your PPE and save you money.

TotalCare services include:

- **Advanced Inspection**
- **Advanced Cleaning**
- **Decontamination & Disinfection**
- **Repairs**
- **Retrofits & Alterations**
- **Rental Gear**
- **Emergency Back-Up Gear**
- **NFPA 1851 Recordkeeping**
- **Customized Programs**
- **Flat-Rate Programs**



FIRE TRAINING TOOLS



(Car Training Prop)

Creating Realistic, Repeatable Fire Training



LION FIRE TRAINING PRODUCTS INCLUDE:

- Live-Fire Training Props
- Digital Fire Training
- Gas-Based Fire Training
- Smart Class A Fire Training
- Fire Trailers
- Containerized Training
- Fire Training Facilities
- And More Solutions

LION fire safety training tools allow you to safely train your team in various environments. From our **digital training props** that provide realistic, yet controlled scenarios to our gas-based props that evaluate the training situation with real fire to our **fully-customizable carbonaceous fire situations**, LION provides you with the right tools, situations and structures to train based on fire crew experience levels and training goals. Additionally, depending on the system, fire instructors can run repeatable and variable evolutions at the push of a button. Our realistic training tools simulate fire growth and behavior. Thermal sensors, along with self-generating digital flames and sound effects, provide an interactive training experience.



CALL 1.800.421.2926



Smoke and flames where live fire isn't possible

QUICKLY RUN REPEATABLE AND VARIABLE EVOLUTIONS WITH THE SIMPLE PUSH OF A BUTTON

ATTACK™ DIGITAL FIRE TRAINING SYSTEM

The ATTACK™ Digital Fire Training System combines digital flames, sound and smoke to create a range of fire conditions that respond directly to hose line application. Train with a seat of fire in acquired structures, training towers or any other location where live fire isn't possible or practical.

SPEND MORE TIME TRAINING.

The portable panel weighs just 35 lbs. (15.9 kg) which makes it easy to set up or change the location and characteristics of the fire between evolutions. Attach the weighted base to keep the panel stable and upright during your most intense training scenarios. Quickly run repeatable and variable evolutions with the simple push of a button.

SAFETY MATTERS.

Create the seat of fire in acquired structures and old burn buildings where live-fire isn't possible. Train new firefighters on fundamentals before introducing live-fire

and change up the training scenario to challenge veteran firefighters.

DIAL UP THE REALISM FOR EVERY TRAINING SESSION.

The ATTACK panel is tough enough to handle any hose line in your training arsenal. The ATTACK system is designed to work with the LION SG4000™ (ETNA) Smoke Generator, capable of producing over 4,000 cubic feet (630 m³) of smoke per minute. The watertight panel's integrated thermal sensors detect water application and the fire and smoke respond automatically. Our Steam Conversion Technology™ recreates the low visibility conditions present when water is first applied to an actual fire. Add additional ATTACK panels that connected wirelessly to create fire extension scenarios, like flashovers.

AVAILABLE PRODUCTS: A. ATTACK Panel B. Weighted Base with Refillable Water Tank C. Infrared Set-up Remote D. Power Supply for SG4000 (ETNA) Water Resistant Case E. Smoke Generator SG4000 (ETNA) F. Smoke Liquid G. Water Resistant Case for SG4000 H. SmartDummy Rescue I. SmartDummy Nomex Suit J. Industrial Remote K. Smart Dummy Adjustable Talk Voice Box L. Weighted Hose Line M. Digital Nozzle

(Not Shown: ATTACK Transport Case, Cleaning Solution, Flexible Smoke Duct Set, Funnel and ATTACK Digital Nozzle Transport Case)



NOTE: Product availability and design may differ based on market location.

ATTACK™ DIGITAL FIRE TRAINING SYSTEM

Specifications

FEATURES

- Class A, B and C fire settings
- 10 difficulty level settings
- Customizable audio and smoke settings

PANEL DIMENSIONS

- 28" x 22" x 6"
(71 cm x 56 cm x 15 cm)
- **Weight:** 35 lbs. (16 kg.)

WEIGHTED BASE

- **Weight:** 33 lbs. (15 kg.) empty
400 lbs. (181 kg.) filled with water

ELECTRICAL

- **Air Pressure Connection:**
110/240 AC @50/60 HZ 2 amps

POWER CABLE

- Standard power cable,
50 ft. (15 m)

OPTIONAL ACCESSORIES

- **Industrial Remote:**
This waterproof remote allows the instructor to be present during the evolution without worrying about damaging the controls.
- **Wall-Mounting Brackets:**
Affix the ATTACK panel to any wall in your training facility.

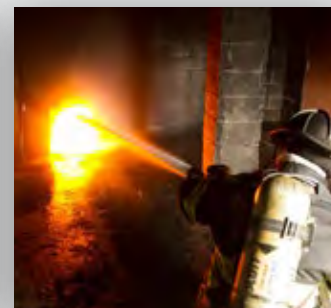

CLASSES OF FIRE (BY COUNTRY)

FUEL SOURCE	EN (US)	EN (UK)	DE	ES	FR	NL
Combustible Materials	Class A	Class A	Klasse A	Clase A	Classe A	Klasse A
Flammable Liquids	Class B	Class B	Klasse B	Clase B	Classe B	Klasse B
Flammable Gas	-	Class C	Klasse C	Gas Inflamable	Classe C	Klasse C
Electrical	Class C	Electrical	Elektrik	Clase C	Risques Electriques	Elektrisch

AVAILABLE PRODUCTS:

A. ATTACK Panel B. Weighted Base with Refillable Water Tank C. Infrared Set-up Remote D. Power Supply for SG4000 (ETNA) Water Resistant Case E. Smoke Generator SG4000 (ETNA) F. Smoke Liquid G. Water Resistant Case for SG4000 H. SmartDummy Rescue I. SmartDummy Nomex Suit J. Industrial Remote K. Smart Dummy Adjustable Talk Voice Box L. Weighted Hose Line M. Digital Nozzle

(Not Shown: ATTACK Transport Case, Cleaning Solution, Flexible Duct Set, Funnel and ATTACK Digital Nozzle Transport Case)



NOTE: Product availability and design may differ based on market location.

Popular Packages

COMPONENT	BASIC	PLUS	TRAINER'S	ULTIMATE
ATTACK™ Digital Fire Training Panel	1	1	1	1
Setup Remote	1	1	1	1
Weighted Base with Refillable Water Tank	1	1	1	1
ATTACK™ Transport Case	1	1	1	1
ATTACK™ Industrial Remote		1	1	1
SG4000 (ETNA) Smoke Generator		1	1	1
SG4000 (ETNA) Smoke Generator Waterproof Case, V2 (WiFi Enabled)		1	1	1
Smoke Liquid (20 Liter)		1	1	1
5 Liter Cleaning Solution for Smoke Generators		1	1	1
Flexible Smoke Duct Set for Smoke Generators		1	1	1
ATTACK™ Digital Nozzle			1	1
Transport Case for ATTACK™ Digital Nozzle			1	1
50 ft. (15 m.) Weighted Hose Line			1	1
SmartDummy™ Rescue (55 lbs./24 kg.)				1
SmartDummy™ Nomex Suit				1
SmartDummy™ Adjustable Call Voice Box				1



Realistic, hands-on fire extinguisher training

LASERS SIMULATE THE DISCHARGE OF
ACTUAL EXTINGUISHERS FOR A COMPLETELY
CLEAN, SAFE TRAINING EXPERIENCE

BULLSEYE™ DIGITAL FIRE EXTINGUISHER TRAINING SYSTEM

Don't let the first time they handle an extinguisher be during a real fire. Prepare them to successfully put out a fire using the BullsEye Digital Fire Extinguisher Training System.

TRAIN ANYWHERE.

The BullsEye allows you to train in places where emergencies may really occur, like schools, workplaces or the home. Training can now take place completely indoors, allowing you to train anywhere, anytime. With the BullsEye's quick connects, one person can plug the system in, set it up and be ready to train in just one minute. Quickly relocate the system during training to change up the evolution and test your trainees' skills.

TEST THEIR SKILLS.

Make sure they're prepared for a real fire by testing their skills – sensors allow the BullsEye to sense trainees' actions and respond like a real fire. The flames

will only subside and go out if the trainee uses the proper **P.A.S.S.** (Pull the extinguisher pin. Aim the nozzle low at the base of the fire. Squeeze the lever above the handle. Sweep the nozzle from side to side.) method. BullsEye extinguishers are set to discharge for the same amount of time as a real extinguisher, and are weighted accordingly 5lb (2.5kg), 10lb (6kg) or 20lb (9kg) to closely simulate actual extinguishers. Smoke generators emit the proper amount of smoke based on the size of the fire and time since ignition to further enhance the realism of the evolution.

SPEND MORE TIME TRAINING, LESS TIME CLEANING UP.

The BullsEye uses lasers to simulate the discharge of actual extinguishers for a completely clean and safe training experience. Similarly, our training smoke does not leave a residue, so your trainees can enjoy effective training without the hazards of conventional extinguisher training.

AVAILABLE PRODUCTS: A. R.A.C.E. Station Case B. R.A.C.E. Station C. BullsEye Extinguisher Carrying Case D. BullsEye Laser Extinguishers E. NFPA "Fire Extinguishers at Work" DVD F. Power Supply G. BullsEye Panel H. Standard Remote I. BullsEye Transport Case J. iPad & Tablet Control K. SG1000/VICO Smoke Generator (with battery)

(Not Shown: 7X SmartExtinguishers, Recharge Accessories and Extingisher Carrying Case)



NOTE: Product availability and design may differ based on market location.

BULLSEYE™ DIGITAL FIRE EXTINGUISHER TRAINING SYSTEM

Specifications

PATENTED FEATURES

- **Extinguishers:** Air/Water SmartExtinguishers® or waterless laser extinguishers interact with sensors embedded in the panel
- **Extinguisher Sensing Control System:** Varies flames automatically based on SmartExtinguisher or BullsEye extinguisher input
- Combustible materials, flammable liquids, flammable gas and electrical fire class settings
- Difficulty level settings (Levels 0 -10)
- Custom training scenarios
- Electronic training records

PHYSICAL SPECIFICATIONS

- **Overall Base Unit Dimensions:** 28 ½" x 26" x 4 ¾" (72 cm x 66 cm x 12 cm)

- **Base Unit:** Stainless Steel
- **Base Unit Weight:** 31 lbs. (14kg.)

CONTROLS

- Wireless IR remote
- Optional wireless touch screen tablet

SMARTEXTINGUISHER

- **Air Pressure Connection:** Schrader Valve
- **Recommended Pressure:** 100 PSI (690 kPa)
- **Maximum Pressure:** 110 PSI (758 kPa)
- **Minumum Pressure:** 90 PSI (620 kPa)
- **Fill Volume:** 5X: 4 liters, 7X: 6 liters
- **Volume/Trainee:** 5X: 0.80 liters, 7X: 0.85 liters

BULLSEYE EXTINGUISHER

- Infrared signal with green laser display
- **Maximum Output:** 5mW
- **Wave Length:** 532nm
- Class 3R laser product
- Speaker simulating extinguisher discharge

- Ultrasonic emitter for extinguisher distance detection
- Extinguisher type detection
- Rechargeable NiMH 7.2 V

BULLSEYE EXTINGUISHER CHARGER

100-240V AC, 50/60Hz, 0.6A input, 12V DC, 1.5A output

CLASSES OF FIRE (BY COUNTRY)

FUEL SOURCE	EN (US)	EN (UK)	DE	ES	FR	NL
Combustible Materials	Class A	Class A	Klasse A	Clase A	Classe A	Klasse A
Flammable Liquids	Class B	Class B	Klasse B	Clase B	Classe B	Klasse B
Flammable Gas	-	Class C	Klasse C	Gas Inflamable	Classe C	Klasse C
Electrical	Class C	Electrical	Elektrik	Clase C	Risques Electriques	Elektrisch

AVAILABLE PRODUCTS:

A. R.A.C.E. Station Case B. R.A.C.E. Station C. BullsEye Extinguisher Carrying Case D. BullsEye Laser Extinguishers E. NFPA "Fire Extinguishers at Work" DVD F. Power Supply G. BullsEye Panel H. Standard Remote I. BullsEye Transport Case J. iPad & Tablet Control K. SG1000/VICO Smoke Generator (with battery)

(Not Shown: 7X SmartExtinguishers, Recharge Accessories and Extingisher Carrying Case)



NOTE: Product availability and design may differ based on market location.

Popular Packages

COMPONENT	BASIC	PLUS	TRAINER'S	ULTIMATE
BullsEye™ Digital Simulation Panel (Water-enabled option also available)	1	1	1	1
BullsEye™ Transport Case	1	1	1	1
Setup Remote	1	1	1	1
BullsEye™ 2 kg/5 lb Dry Chemical Digital Laser Extinguisher	1	2	2	2
Industrial Grade Extinguisher Carrying Case *	1	1	1	1
5X SmartExtinguisher **	1	2	2	2
Air Compressor with Accessories **	1	1	1	1
iPad Mini with iPad control		1	1	1
NFPA Fire Extinguishers at Work DVD		1	1	1
Training Record Management Software			1	1
Scenario Customization Software			1	1
R.A.C.E.™ Station			1	1
Transport Case for R.A.C.E.™ Station			1	1
SG1000/Vico™ Smoke Generator with Wall Power Base				1
NiMH Battery Base for SG1000/Vico™ Smoke Generator				1
Smoke Liquid (1 Liter)				1
Smoke Liquid (5 Liter)				1

* Extra carrying case is added when water-enabled BullsEye is selected

** Only available with water-enabled BullsEye™

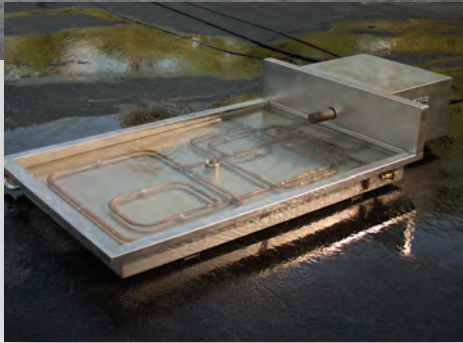

The first step to transforming your training

ONCE YOU OWN THE BASE SYSTEM, ADD ANY OF THE MODULAR FIRE TRAINING PROPS TO EXPAND YOUR TRAINING ARSENAL FOR A FRACTION OF THE COST

ADVANCED HOSE LINE TRAINING SYSTEM

The LION Hose Line Training System is a heavy-duty fire training tool designed to handle the requirements of advanced fire suppression training. The system's stainless steel construction and rugged components mean you can run evolution after evolution for years to come. Hit the system with virtually anything in your firefighting arsenal for intense hands-on training.

FOCUS ON SKILLS WHILE KEEPING THEM SAFE

The instructor operates the system via a remote control unit with emergency controls, so you can focus on your trainees' skills while keeping them safe. Start and stop technology lets you pause the evolution to review technique and correct mistakes when they're made, not after. Don't forget to add the wireless remote to teach proper tactics up close — not yards away.

Challenge your firefighters to fight the Hose Line Training System with extinguishers or water streams for full-scale hands-on training. With high intensity output, your trainees feel the heat and learn how to respond. Create fire and change the intensity of the flames with the push of a button. Create fixed fires or set them to spread them across multiple zones.

INTERCHANGEABLE PROPS FOR EFFECTIVE TRAINING

The Hose Line Training System combines with our exclusive network of live-fire training props to grow with you and your department. Now that you have our burn tray and console system, easily add on the props for a fraction of the cost. Available props include the Vehicle Fire Prop, Pressure Vessel Fire Prop, Helicopter Fire Prop, and more.



AVAILABLE PRODUCTS: A. Barbeque Grill B. Dumpster C. Electric Motor D. Gas Meter E. Paint Locker F. Pipe and Valve Assembly (Christmas Tree) G. Split Pipe Flange H. Propane Cylinder I. Stove J. Trashcan K. Helicopter L. Pressure Vessel M. Vehicle

ADVANCED HOSE LINE TRAINING SYSTEM

Specifications

BURN TRAY

- **Length:** 72" (183 cm)
- **Width:** 8" (122 cm)
- **Construction:** Stainless steel
- **Fuel:** Liquid propane
- **Weight:** 170 lbs. (77 kg.)
- **Control:** Wire remote with dead-man button, optional wireless remote
- Continuous pilot operation with four burn zones
- Removable pilot module for use with additional props

PILOT BOX

- **Weight:** 108 lbs. (49 kg.)
- Stainless steels housing, brass, copper and aluminum plumbing and fittings

- **Propane Usage:** Average of 6 gallons (22.7 liters) per minute; Maximum of 10 gallons (37.9 liters) per minute at full burn rate

WHAT'S INCLUDED

- **Pilot Module:** The industrial grade forced-air pilot guarantees reliable ignition, even under the most demanding circumstances.
- **Burn Tray:** Multiple burners create four distinct burn zones that can be ignited individually or in any combination. The water bath design ensures even fuel distribution and protects burners from intense heat.
- **Mobile Control Console & Wired Remote:** Easily start, stop, and control all aspects of the evolution.

OPTIONAL TRANSPORT TRAILER*

- Move skid-mount and caster-mount props from site to site with the transport and supply trailer. In addition to a built-in winch, the trailer houses the propane supply system complete with storage tanks and supply lines.

WIRELESS REMOTE OPTION

- The industrial grade hand-held wireless remote controls all aspects of the evolution and includes a safety stop button.



* Transport Trailer not available in all locations.



Prop Specifications

	HEIGHT		WIDTH		DEPTH		WEIGHT	
	IN.	M.	IN.	M.	IN.	M.	LBS.	KG.
Burn Tray	17.00	0.43	72.00	1.83	48.00	1.22	170	77.1
Pilot Box	17.08	0.43	34.93	0.89	22.05	0.56	108	49.0
Vehicle	53.41	1.36	152.55	3.87	68.20	1.73	1,800	816.5
Boil Over	94.06	2.39	89.00	2.26	64.00	1.63	1,600	725.7
Pipe and Valve Assembly	73.68	1.87	39.22	1.00	39.79	1.01	70	31.8
Dumpster	45.72	1.16	80.21	2.04	44.45	1.13	700	317.5
Split Pipe Flange	13.48	0.34	76.88	1.95	30.88	0.78	130	59.0
Gas Meter	36.20	0.92	29.40	0.75	20.21	0.51	110	49.9
Barbeque Grill	38.63	0.98	64.00	1.63	22.24	0.56	380	172.4
Helicopter	102.25	2.60	291.75	7.41	262.75	6.67	4,600	2,086.5
MegaTray	16.91	0.43	152.00	3.86	101.00	2.57	560	254.0
Electric Motor	26.32	0.67	48.38	1.23	19.68	0.50	120	54.4
Paint Locker	60.05	1.53	36.00	0.91	36.95	0.94	290	131.5
Pressure Vessel	63.05	1.60	90.31	2.29	27.56	0.70	700	317.5
Propane Tank	46.00	1.17	52.50	1.33	25.06	0.64	190	86.2
Stove	35.94	0.91	35.21	0.89	30.65	0.78	300	136.1
Trashcan	38.35	0.97	48.74	1.24	25.83	0.66	300	136.1

AVAILABLE PRODUCTS:

- A. Barbeque Grill
- B. Dumpster
- C. Electric Motor
- D. Gas Meter
- E. Paint Locker
- F. Pipe and Valve Assembly (Christmas Tree)
- G. Split Pipe Flange
- H. Propane Cylinder
- I. Stove
- J. Trashcan
- K. Helicopter
- L. Pressure Vessel
- M. Vehicle



The car fire that provides up to 10 years of training

A REALISTIC VEHICLE FIRE TRAINING PROP THAT CAN BE REPEATED AND CUSTOMIZED TO FIT THE NEEDS OF YOUR TRAINEES

VEHICLE FIRE TRAINING PROP

Forget spending countless hours to burn a car just once – our vehicle is built to handle the toughest training, for years to come. The LION Vehicle Fire Prop is a heavy-duty training tool with intense flames, real heat and smart controls. Four distinct burn zones allow you to create engine, passenger compartment, fuel spill and tire fires to challenge trainees. The smashable lights, pry-able hood, integrated smoke and sound effects combine to create a scenario so real your trainees' palms will sweat. Create fixed fires or set them to spread them across multiple zones to focus on specific skill sets.

BUILT TO LAST

The prop's working doors, hood and trunk are built tough to take evolution after evolution of live-fire training. In fact, all of our props are rated to burn for at least ten years, thanks to ¼ inch (0.64 cm) military grade steel and an integrated cooling system.

ESCALATE YOUR TRAINING AS YOUR DEPARTMENT GROWS

LION's exclusive network of live-fire training props grows with you and your department. Now that you have our control system, pile on the props for a fraction of the cost.

GET THE MOST OUT OF YOUR TRAINING TIME

Ignite the propane-based flames and have full command of each evolution with the instructor's controller. Quick connects mean you'll be ready to train in minutes. Create engine, passenger compartment, fuel spill, and tire fires with the push of a button. Plus, the wireless remote means you can teach the proper tactics up close – not yards away.



AVAILABLE PRODUCTS:

A. Control Console **B.** Pilot Module **C.** Transport Trailer* **D.** Burn Tray **E.** Integrated Smoke and Sound **F.** Pry-able Hood and Knock Out lights with replaceable panels

VEHICLE FIRE TRAINING PROP

Specifications

WHAT'S INCLUDED

The vehicle fire prop's working doors, hood and trunk are built tough to take evolution after evolution of live-fire training. The LION prop platform is based on the following three components:

- **Pilot Module:** An industrial grade forced-air pilot that guarantees reliable ignition, even under the most demanding circumstances.
- **Burner Tray:** Multiple burners configured to create four distinct burn zones that can be ignited individually or in any combination. Waterbath design ensures even fuel distribution and protects burners from intense heat.
- **Cooling System:** The integrated cooling system keeps steel cool to

prolong the life of the prop and allows for long duration, heavy fire exercises. Cooling system components are hidden to maintain the realistic look and feel of the props.

VEHICLE PROP

- **Length:** 152.5" (367.5 cm)
- **Width:** 69" (175 cm)
- **Height:** 53.5" (136 cm)
- Galvanized Steel Frame, 11 gauge (5mm) cold rolled steel with fire-proof paint or optional stainless steel
- **Weight:** 1800 lbs. (816.5 kg.)

PILOT BOX

- **Weight:** 108 lbs. (49 kg.)
- **Base Unit:** Stainless Steel

- Stainless steels housing, brass, copper and aluminum plumbing and fittings
- Average of 6 gallons (22.7 liters) per minute; Maximum of 10 gallons (37.9 liters) per minute at full burn rate.

VEHICLE FIRE PROP OPTIONS

- **Stainless Steel Construction:** Choose between standard heat resistant carbon steel or stainless steel prop construction.
- **Sound Effects:** Heat shielded components create fire and engine noise effects as well as the sound of tires popping and gas shocks exploding. Additional sound effects may be added based on your specific training objectives.

- **Smoke:** Add smoke to create visibility restriction and help teach trainees to attack the fire from upwind and uphill. LION Smoke Generators can be integrated into the prop and are controlled with the standard instructor's controller. Because continuous operation smoke generators are included, you get smoke whenever you want it.



* Transport Trailer not available in all locations.



Mannequins made for even the toughest environments

RUGGED, INTERACTIVE MANNEQUINS THAT PROVIDE REALISTIC RESCUE SITUATIONS YEAR AFTER YEAR

SMARTDUMMY™ RESCUE & EXTRICATION MANNEQUINS

LION's SmartDummy rescue mannequin is tough enough to take on intense fire training and smart enough to interact with rescuers.

Built with rugged, "firefighter-proof" materials, the SmartDummy rescue mannequin can handle your toughest training requirements. Internal weighted padding and a flexible design provide uniform weight distribution and realistic feel.

The interactive built-in VoiceBox makes it easy to record messages in between evolutions. Choose between continuous or sound activated playback. The SmartDummy rescue mannequin can cough, call out for help, or direct rescuers to find additional victims.

RESCUE MANNEQUIN

The SmartDummy is designed to withstand your toughest training evolutions. In addition to crush-resistant materials, the mannequin comes with a rugged uni-shell covering, removable boots and a Drag Rescue Device (DRD strap).

The SmartDummy's internal weighted padding provides even weight distribution so that it feels like a real victim. Flexible joints enable a full range of mobility without pinch points. The programmable VoiceBox is located in the head for ease of access.

EXTRICATION MANNEQUIN

Create victim removal scenarios with the extrication SmartDummy. Simulate a variety of serious bodily injuries including torso impalement or a severed arm or leg. The built-in VoiceBox gives your victim a voice and adds intense interactivity to the scenario.



Accident & Entrapment Training



AVAILABLE PRODUCTS: A. SmartDummy Rescue Mannequin B. SmartDummy Extrication Mannequin C. NOMEX® Suit D. Weighted Vest

SMARTDUMMY™ RESCUE & EXTRICATION MANNEQUINS

Specifications



Interactive VoiceBox Programming

VOICEBOX

Bring the LION SmartDummy to life with the interactive VoiceBox.

- **Integrated Microphone:** Press and hold the record button to capture a message or sound effect.
- **Continuous/Sound-Activated Mode:** Set the VoiceBox to play messages continuously or

respond only when noise is detected.

- **Volume Control:** Turn up the volume to train how to stay cool with frantic victims. Turn down the volume for extrication victim breathing or moaning sounds.
- **Reaction Sensitivity:** Adjust the minimum noise level required to activate the VoiceBox in Sound-Activated Mode.

TRAINING OPPORTUNITIES

The SmartDummy was built to be a better rescue mannequin for a full range of training scenarios. The SmartDummy moves, feels and sounds like a real victim for training scenarios including:

- F.A.S.T.
- Building Collapse
- Vehicle Extrication
- Confined Space
- Wall Breach Extrication
- Entrapment

ADDITIONAL DETAILS

Mannequin Body:

- **Weight:** 55 lbs. or 110 lbs. standard (24.95 kg or 49.89 kg)
- **Height:** 5' 10" (177.8 cm)

VoiceBox:

- **Power:** Four AA batteries power the VoiceBox for up to 9 hours in

Continuous Mode or 15 hours in Sound-Activated Mode

- **Volume:** 0-80 dB at 3 ft. (91.44 cm)

OTHER ACCESSORIES

- **Weighted Vest:** Constructed of rugged reinforced nylon – conforms to the dimensions of the SmartDummy. Features four durable Velcro straps and is fully adjustable up to 60 pounds (27.21 kg).
- **NOMEX Suit:** Flame-resistant suit designed to fit the SmartDummy with or without the optional Weighted Vest. Suit is machine washable and safe for use in live-fire training evolutions.



Take realistic interactive fire safety training on the road

EXPAND YOUR COMMUNITY FIRE SAFETY EDUCATION REACH WITH MOBILE TRAINING CENTERS

FIRE SAFETY TRAILER

LION Fire Safety Trailers are interactive and highly realistic fire prevention training aids that can be tailored to both children and adults.

Train adults with simulated fire situations that are intense, realistic, and completely safe. Features include digital flames, smoke, heat, and integrated sound effects that simulate emergencies in the home or at the workplace.

Provide children with important fire safety lessons including EDITH drills and hazard recognition. Add a severe weather package to train everyone in your community how to respond to a weather emergency.

COMPREHENSIVE TRAINING

Comprehensive response training should include multiple elements involving environmental assessment, decision making, action, and reaction. The combination of these elements in LION Fire Safety Trailers are designed to incorporate each of these key elements:

- **SITUATIONAL SIMULATION:** mimic appropriate environment/props
- **DECISION-MAKING SIMULATION:** size-up environment assess multiple options
- **COMMUNICATION SIMULATION:** when and how to share information
- **EMOTIONAL SIMULATION:** create stress and uncertainty
- **PHYSICAL SIMULATION:** develop required physical skills



FIRE SAFETY TRAILER FEATURES



KITCHEN FIRE SCENARIO

The Kitchen Fire Scenario begins as an oven fire and spreads to a pan on top of the stove. If left unchecked, the fire can spread to the trash can next to the stove. Heat and smoke intensify, triggering smoke alarms and requiring the appropriate action of the trainee to call 911, extinguish the flames or evacuate if necessary.

The optional kitchen hazard recognition package adds a smoking toaster, smoking outlet, chemical cabinet and a mounted TV/DVD player for safety videos.



BEDROOM FIRE SCENARIO

In the Bedroom Fire Scenario, teach how to feel for heat and stop smoke from coming into the room with the heated, smoking door. Show children how to find a second way out with the EDITH (Exit Drills In The Home) map and escape window.

For adult learning, the Interactive Bedroom Fire package adds a smoldering trashcan and interactive 911 phone. Trainees must call 911 and use a BullsEye laser extinguisher to put out the flames before the fire grows too large, forcing evacuation.

Intense infrared heaters, smoke effects, sound effects, and LION's Digital Flames create a realistic, yet completely safe training environment. A briefing room, embedded video cameras and wireless video transmission that depicts live interior action enable robust education and training opportunities for your community.



INDUSTRIAL FIRE SCENARIO

The Industrial Fire Scenario begins as an electrical box shorts causing sparks to ignite the adjacent parts washer. The parts washer creates a hot, smoky fire which then ignites the nearby trash can resulting in a full scale industrial emergency.

As smoke, heat and digital flames intensify, trainees must pull down the alarm, call 911, shut-down the power and use an extinguisher to successfully control the emergency. The optional paint locker fire prop with integrated flames, smoke and sound effects can be added to further challenge trainees.

The industrial hazard recognition package option adds interchangeable placard and chemical drum prop, gas leak prop, lock-out tag-out prop, smoking outlet and a mounted TV/DVD player for safety videos.

BEST SELLING FIRE SAFETY TRAILERS

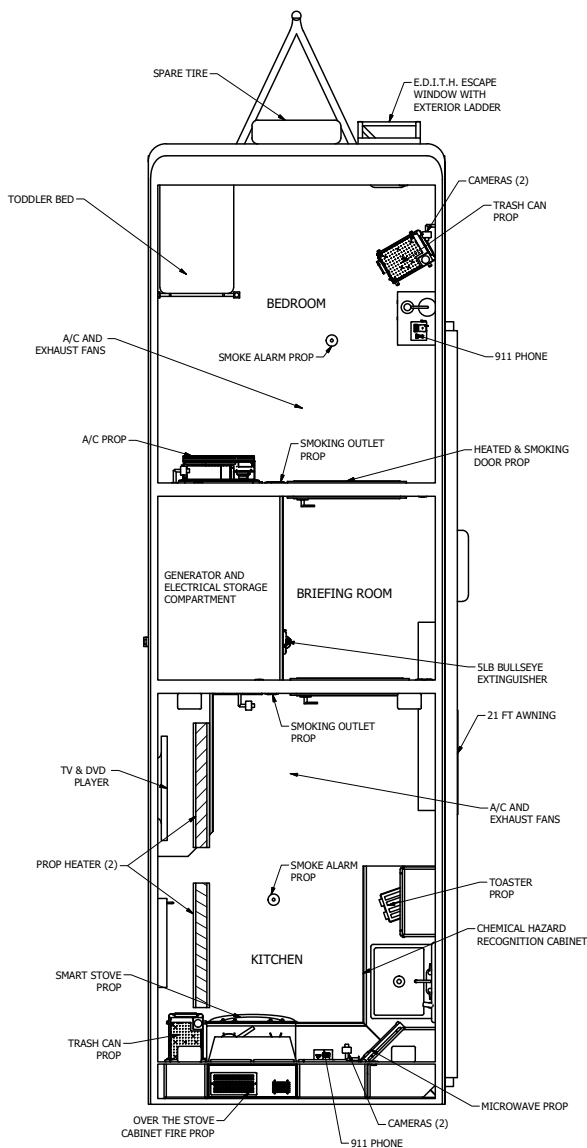
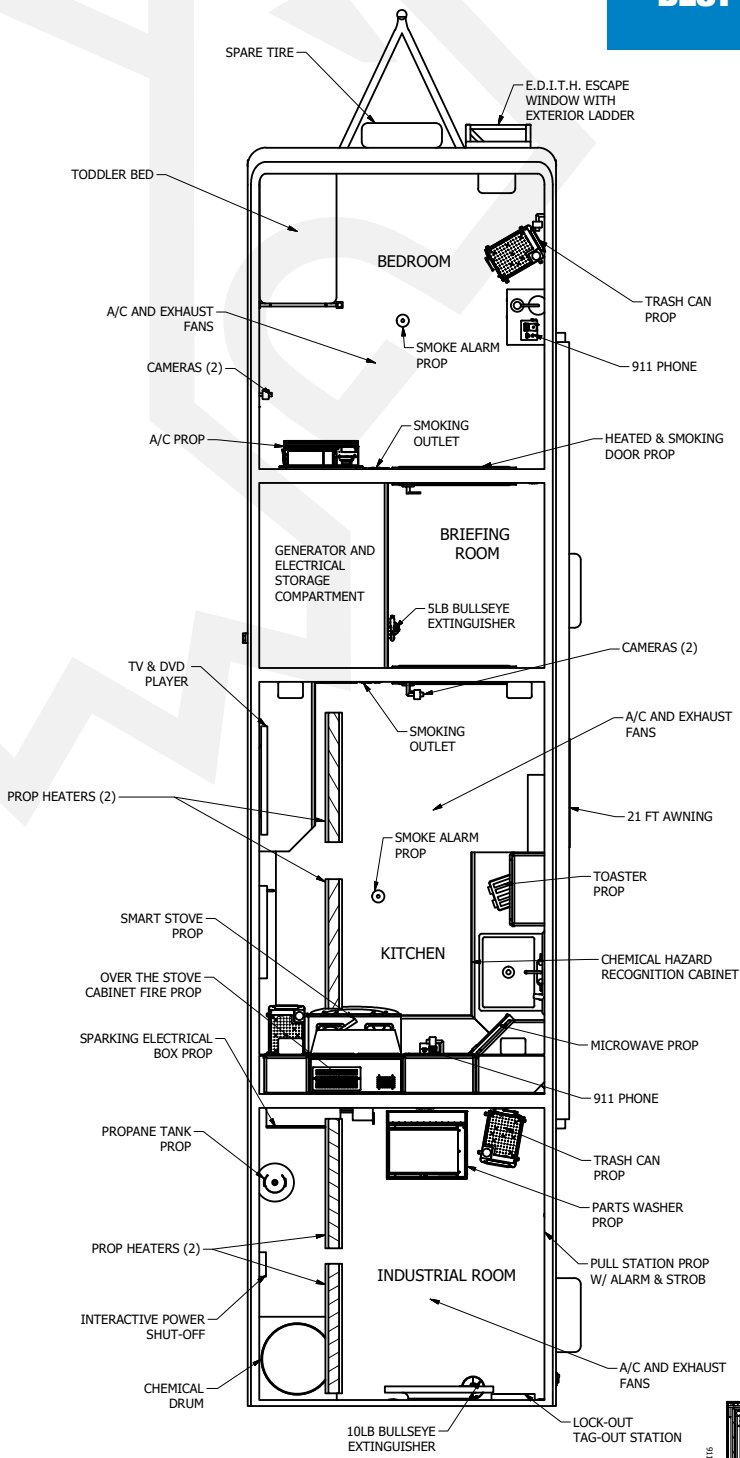

**21 FT FIRE SAFETY TRAILER
BEDROOM & KITCHEN**

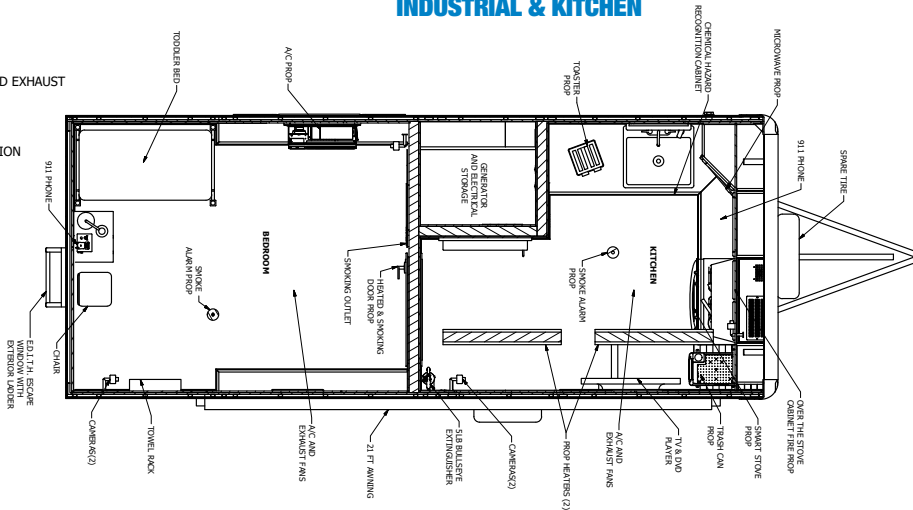

The background of the advertisement features a stylized American flag with a dark field of white stars and a red and white striped field. The bottom portion of the image is dominated by bright, intense orange and yellow flames. The word "COVERT" is prominently displayed in the center, rendered in a bold, metallic, 3D-style font with a green-to-yellow gradient. Below it, the word "ARMOR" is presented in a simpler, green, blocky font within a white rectangular box.

COVERT

A R M O R

**DESIGNED FOR FIREFIGHTERS & MEETS THE
NEW NFPA 3000 STANDARD**

F1-Universal Fire Carrier

The F1-Universal Fire Carrier, designed specifically for Fire and EMS personnel as a 1 size fits all, alleviating the need to have multiple sized vests or make time consuming size adjustments when lives are at stake. The F1 comes standard with our NIJ certified Level IIIA soft armor panels and 10"x12" hard armor rifle plate pockets front and rear. The F1 design and colors were based on Firefighter needs so there is no confusion in the field.



Features:

- Fully adjustable and padded shoulder strap for maximum comfort and adjustability.
- Front & rear plate pocket accommodates both full size and shooters cut rifle armor plates
- Large Front Utility pocket with hook & loop closure for I.F.A.K. and/or Radio
- One size fits with 360° of 3M™ Scotchlite™ reflective tape to make you more identifiable
- Reinforced drag handle
- Large loop area on front/back for ID placards
- Colors Available: Black (BLK), Red (RED) Yellow (YEL) Tan (TAN) Navy (NVY)



C3-Emergency Response Carrier

The C5-E.R.C. is a custom or standard sized vest available for First Responders with optional ballistic inserts or as a replacement carrier for your ballistic panels. The MOLLE load carrying system enables the user to attach various pouches for user needs.



Features:

- 3M™ Scotchlite™ reflective tape for high visibility
- Hi-Vis front and rear identification
- Front & rear pocket accommodates both full size and shooters cut Level III or IV hard armor plates
- Custom & Standard sizes available for maximum comfort
- Fully adjustable waist and shoulders
- Available in NIJ 0101.06 Threat Level II or IIIA
- Colors: Black (BLK), Red (RED), Navy (Nvy), and Tan (CT)



CAI offers a complete line of NIJ 0101.06 Certified soft and hard body armor and can be found on the NIJ Compliant Product List (https://justnet.org/compliant/ballistic_cpl.html). Please contact us to assist in putting together the right package based on your agency needs.

F2-Universal Plate Carrier

The F2-Universal Plate Carrier, designed for Fire/EMS Rescue Task Force and SWAT Medics as a scalable vest able to hold all types and sizes of soft and hard armor to offer better coverage for different body types.

Features:

- Fully adjustable and padded shoulder for maximum comfort and adjustability.
- Front & rear accommodates all size and shape Level III or IV hard armor plates available
- Large Front Utility pocket with hook & loop closure for IFAK and Kangaroo pocket for storage or specialty inserts
- One size fits most with optional 360° of 3M™ Scotchlite™ reflective tape to make you more identifiable
- Reinforced contrasting drag handle
- Large loop area on front/back for ID placards
- Colors: Black (BLK), Red (RED), Tan (TAN) and Navy(NVY)



P1-Plate Carrier

The P1-plate carrier was designed for Firefighters and EMS personnel who need the upgraded protection of a ballistic carrier system with expandable load carrying capacity. On the body side the P1 uses closed cell foam and has a 4 point adjustment. Our P1 is listed as one size fits most.

Features:

- Fully adjustable shoulder straps and closed cell foam padding to protect the upper body for maximum comfort
- Optional Cummerbund Systems(Velcro or buckle front closure and rear size adjustment)
- Optional NIJ Level IIIA ballistic inserts available for Cummerbund Armor Panels (6"x6", 6"x8" and 6"x12")
- Reinforced drag handle
- 4" x 6" MOLLE ID placards available
- Kangaroo pouch with snap & Velcro closure
- Available in Red(RED) & Black (BLK)



Body armor carry bag holds two complete ballistic kits including plates with a large front pocket. Available with or without reflective trim. Available in Black, Navy, Red, or Coyote Tan.

H1-ACH IIIA Helmet

The H1-ACH IIIA Helmet is designed according to the latest US Military requirements, utilizing the most advanced ballistic protection against handgun threats. The shell is composed of multi-layered Kevlar based advanced composite. The harness assembly consists of the ACH Comfort suspension system and a four point harness with a leather lined chin strap. The reduced profile enables a wider peripheral and upward field of view, for better situational awareness and unrestricted movement, and also accommodates various options: ratched dial suspension system for universal sizing, rails for mounting optional accessories, NVG shroud mount, velcro & bungee system.



Design:

- Protection Level IIIA Stand Alone
- Multi-hit capability
- Kevlar based Advanced Ballistic Matrix Materials
- Threat Protection: .357 SIG FMJ, 44 MAG SJHP.
- Also provides protection against handgun threats in NIJ types I, IIA and II
- Built in 7 Pad Interior for impact protection
- Standard 4 point harness
- Available in Small, Medium, Large and X-Large
- Available in 3 colors: Black, Tan, OD Green



Covert Armor International
1101 Clare Avenue, Unit #2
West Palm Beach FL, 33401

(844) COVERT1
(844) 268-3781
www.COVERTARMOR.com

THE COLD TRUTH

ABOUT WARM ZONE RESCUE



**“Police stop the killers.
Firefighters stop the dying.”**

- Dr. Denis Oniel
Deputy U.S. Fire Administrator
December 2017

During Active Shooter / Hostile Event Response (ASHER) situations, Ballistic Protection is the key to Safety for All.

Our Staff of Retired Fire Chiefs and Experienced Sales Personnel are standing by to help you select the right High-Performance, Industry-Leading Equipment for your Team.



LION MEDPRO

Advanced construction and optional enhancements for comfort, safety and mobility with Bloodborne Pathogen resistant liner to prevent liquid penetration. *Certified to meet NFPA 1999 standards for EMS Duty.*

LION TR51

For rescue and recovery, tough and durable with reflective materials and removable, Bloodborne Pathogen resistant liner to prevent liquid penetration. *Certified to meet NFPA 1999 and 1951 standards, for both EMS Duty and Technical Rescue (TR) tasks*

LION VERSAPRO

More protection than a station uniform, strong and durable for non-fire calls. *Certified to meet NFPA 1951 and 1977 standards for both Technical Rescue and Wildland Firefighting*

TSF Fire Equipment is a Service Disabled, Veteran-Owned Small Business (SDVOSB) Distributor, committed to providing outstanding service and the best deals on the Highest-Quality Firefighter Gear and Personal Protective Equipment (PPE).

TSF Fire Equipment stands ready to facilitate your Active Shooter Hostile Events Response Program (ASHER). Contact us for options and Best Pricing!



TSF Fire Equipment is Now Offering Covert Armor!
In Support of Your NFPA 3000 Active Shooter/Hostile Event Response (ASHER) Program



“Universal Fit”

- Multiple Carrier Designs
- Level II or IIIA Ballistic Panels (IAW NFPA 3000 Requirements)
- Up-Armor to Level III or IV with Inserted Rifle Plates



TSF Fire Equipment

For Best Pricing and Assistance, Contact Us at:

877-841-3984
<http://www.tsfequip.com>



Find the best prices on the personal protective equipment used by every branch of the military.

FIREFIGHTING BATTERY-POWERED BLOWERS

VS-1.2 BATTERY POWER BLOWER



10,887 CFM

Our Tech Series is an innovative line of positive pressure blowers featuring ergonomic design features and leading-edge motor technology and performance. Engineered for performance, durability, versatility, and ease of use. The VS-1.2 includes a tall fold down handle to make deployment and storage easier.



Dimensions (W x D x H)
22.88" X 11" X 26"

Model No.	Part No.	Size	HP	CFM	Description	Weight
VS1.2	910-1825	18"	0.9	10887	VS-1.2 Standard Plus <i>INCLUDES 1 Battery / 1 Charger</i>	53 lbs.
VS1.2	910-1827	18"	0.9	10887	VS-1.2 Deluxe <i>INCLUDES 2 Batteries / 1 Charger</i>	53 lbs.

VS-1.2D DEWALT BATTERY POWER BLOWER



10,887 CFM

The newest addition to our innovative line of Tech Series positive pressure blowers, the VS-1.2D DeWalt FLEXVOLT battery-driven blower features a taller fold down handle to make deployment and storage easier.



Conversion kits are available!

Model No.	Part No.	Size	HP	CFM	Dimensions (W x D x H)	Weight
VS1.2D	910-1861	18"	0.9	10887	22.88" X 11" X 26"	41 lbs. <i>INCLUDES 3 - 12Ah DeWalt Batteries & 1 Single-Bay Charger</i>
VS1.2D	910-1862	18"	0.9	10887	22.88" X 11" X 26"	41 lbs. <i>INCLUDES 3 - 12Ah DeWalt Batteries & 1 4-Bay Charger</i>
VS1.2D	910-1863	18"	0.9	10887	22.88" X 11" X 26"	53 lbs. <i>INCLUDES 3 - 9Ah DeWalt Batteries & 1 Single-Bay Charger</i>

BB-16 BLOWER WITH REMOVABLE BATTERY



10,940 CFM

BB-16 is quicker to set-up than conventional fans. Thanks to its powerful battery, our IP66-Rated BB-16 is completely autonomous and can be started instantly without wasting time seeking a power outlet.

Dimensions (W x D x H)
22.88" X 11" X 26"

Model No.	Part No.	Size	HP	CFM	Description	Weight
BB-16	910-1801	16"	0.9	10940	Standard <i>1 Battery, Internal Charger Only</i>	41 lbs.
BB-16	910-1802	16"	0.9	10940	Standard Plus <i>1 Battery, Internal Charger Only, 1 Quick-Charger</i>	41 lbs.
BB-16	910-1803	16"	0.9	10940	Deluxe <i>2 Batteries, Internal Charger Only, 1 Quick-Charger</i>	41 lbs.

VS1.2 Accessories

Part No.	Description	Part No.	Description
610-1801	Shoulder Carrying Strap	585-047	Four Bay DeWalt Quick Charger
585-015	Battery 48V 5AH Battery (70 Minutes)	610-1814	Mount Kit 12V Inverter (w/ Charger)
585-030	Charger, Plug In, 110/220 VAC to 48 VDC	610-1810	Mount Kit 12V Inverter (w/ Charger, No Battery Rack)
585-040	DeWalt FLEXVOLT 12AH / 240 WH	725-070 & 725-019	18"x15" or 18"x25" Flex Tube Ducting
585-041	DeWalt FLEXVOLT 9AH / 180 WH	300-141 & 300-142	Door Bar Hanger Bracket Set
585-046	Single Bay DeWalt Quick Charger	725-200	Rehab Misting Ring

BB-16 Accessories

585-035	External Quick Charger	i63.20.025	Ducting - Suction & Ventilation
585-005	Battery 12.5 AH 585 WH, IP65-Rated	i60.20.105	High Expansion foam adapter
i63.20.030	Carrying Harness (Chest or Back Position)	725-200	Rehab Misting Ring

FIREFIGHTING ELECTRIC-POWERED BLOWERS

FIREFIGHTING GAS-POWERED BLOWERS

SINGLE-SPEED ELECTRIC BLOWERS



8,748 to 12,867 CFM

Our **Single-Speed** positive pressure fans feature some of the lightest designs available and are perfect for departments looking to go electric on a limited budget.

Available with hazardous location (*Explosion Proof, EP*) motors which are intended for Class 1, Group C&D and Class 2 Group F&G environments.

Model No.	Part No.	Size	HP	CFM	Dimensions (W x D x H)	Weight
110V/60Hz						
SS-16-S-1.5	910-1200	16"	1.5	11804	20.5" x 19.75" x 21.75"	74 lbs.
SS-18-S-1.0	910-1220	18"	1.0	8748	22" x 21" x 24.25"	76 lbs.
SS-21-S-1.0	910-1240	21"	1.0	11698	24.75" x 21" x 26.25"	81 lbs.
SS-24-S-1.0	910-1260	24"	1.0	12867	28" x 21" x 30"	90 lbs.
200V/50Hz						
SS-16-S-1.5	910-1218	16"	1.5	---	20.5" x 19.75" x 21.75"	---
SS-18-S-1.0	910-1238	18"	1.0	---	22" x 21" x 24.25"	---
SS-21-S-1.0	910-1258	21"	1.0	---	24.75" x 21" x 26.25"	---
SS-24-S-1.0	910-1278	24"	1.0	---	28" x 21" x 30"	---

VARIABLE-SPEED ELECTRIC BLOWERS



11,551 to 15,663 CFM

Our **Variable Speed** Blower is the latest innovation in our variable speed, electric offering and delivers unmatched performance, bridging the gap between gas and electric airflows.

All models feature a class leading 2.0 HP motor and simple to operate 0 to 100 variable speed control. NEMA-4 rated drive provides extra protection in wet environments.

Model No.	Part No.	Size	HP	CFM	Dimensions (W x D x H)	Weight
110V/60Hz						
VS-16-R-2.0	910-1400	16"	2.0	11551	21" x 19.75" x 23"	98 lbs.
VS-18-R-2.0	910-1420	18"	2.0	12839	23" x 21" x 24.9"	104 lbs.
VS-21-R-2.0	910-1440	21"	2.0	14836	26" x 21" x 26.25"	108 lbs.
VS-24-R-2.0	910-1460	24"	2.0	15663	29.5" x 21" x 30"	119 lbs.
200V/50Hz						
VS-16-R-2.9	921-1418	16"	2.9	---	20.5" x 19.75" x 21.75"	81 lbs.
VS-18-R-2.9	921-1438	18"	2.9	---	22" x 21" x 24.25"	86 lbs.

DIRECT DRIVE GAS BLOWERS



11,541 to 20,523 CFM

Our **Direct-Drive** offers the ideal combination of value, performance and durability. All models feature an overhead valve engine that delivers incredible reliability. Our 18" & 21" Direct-Drive Power Blowers are the most popular positive pressure ventilation (PPV) units in the world.

Model No.	Part No.	Size	HP	CFM	Dimensions (W x D x H)	Weight
DD-16-H-4.8	910-1100	16"	4.8	12008	20.5" x 19.75" x 21.75"	79 lbs.
DD-18-H-4.8	910-1120	18"	4.8	14773	22.75" x 21" x 24.25"	85 lbs.
DD-21-H-5.5	910-1140	21"	5.5	20523	25" x 21" x 26.25"	90 lbs.
DD-24-H-5.5	910-1160	24"	5.5	19606	28" x 21" x 30"	99 lbs.
DD-16-B-3.5	910-1101	16"	3.5	11541	20.5" x 19.75" x 21.75"	73 lbs.
DD-18-B-5.5	910-1121	18"	5.5	14341	23.5" x 21" x 25"	83 lbs.
DD-21-B-5.5	910-1141	21"	5.5	18025	25.5" x 21" x 26.25"	87 lbs.
DD-24-B-5.5	910-1161	24"	5.5	19232	28" x 21" x 30"	97 lbs.

SPECIAL OPERATIONS GAS BLOWERS



15,792 to 19,936 CFM

Our **Special Operations** Power Blower is designed to tackle unique fire ground ventilation scenarios, the SP's specialized air pattern is highly effective when ventilating stairwells, complex, multistory and large structures (>5000ft²). This same air pattern is also designed to be deployed 9 to 11 feet from the entry point, providing additional access for personnel.

Model No.	Part No.	Size	HP	CFM	Dimensions (W x D x H)	Weight
SP-18-H-5.5	910-1620	18"	5.5	15792	20.5" x 21.5" x 22.5"	88 lbs.
SP-21-H-8.5	910-1640	21"	8.5	19936	24.25" x 24" x 25.5"	122 lbs.
Available Electric option						
SP-18-V-2.0 (110V)	910-1720	18"	2.0	13338	21.75" x 21.5" x 25.75"	105 lbs.
SP-21-V-2.0 (220V)	910-1739	18"	2.0	13338	21.75" x 21.5" x 25.75"	105 lbs.

LEADER®: EDS230 & EVG230 NEO VARIABLE & SINGLE SPEED ELECTRIC FANS



11,625 to 12,830 CFM

The EVG230 NEO 18" Is our latest electric fan for advanced technology in PPV Fire Fighting operation with GFCI compatibility.

Model No.	Part No.	Size	HP	CFM	Dimensions (W x D x H)	Weight
EDS230	163.10.032N	18"	1.5	11625	21.6" X 22" X 19.3"	44 lbs.
EDS230-2	163.10.033N	18"	2.0	12830	21.6" X 22" X 19.3"	86 lbs.
EVG230	163.10.042N	18"	1.5	11625	21.6" X 22" X 19.3"	78 lbs.

ELECTRIC POWERED SMOKE EJECTORS



up to 11,804 CFM

Smoke Ejectors are still the go to for many departments around the world for their compact size and weight, simplicity and affordability. Perfect for ventilating in confined spaces.

Model No.	Part No.	Size	HP	CFM	Dimensions (W x D x H)	Weight
120V/60Hz						
EB-16-S-0.3	913-1000	16"	0.3	3200	18.75" x 14.25" x 19.5"	47 lbs.
EB-16-S-0.3-EP	913-1001	16"	0.3	3200	18.75" x 14.25" x 19.5"	52 lbs.
EB-16-S-1.5-HP	913-1010	16"	1.5	11804	18.75" x 14.25" x 19.5"	59 lbs.



Clip on Duct Hose Adapter PART 725-177



*Flex Tube Ducting Available 15' PART 725-029 25' PART 725-016

GAS-POWERED SMOKE EJECTORS



11,650 to 14,200 CFM

Our Gas-Powered Smoke Ejectors are perfect for ventilating in confined spaces. Lightweight and compact for convenient lifting/ carrying and storage/transport.

NOT FOR SALE IN USA

Model No.	Part No.	Size	HP	CFM	Dimensions (W x D x H)	Weight
GASOLINE						
GBS-16-S-3.5	911-1014	16"	3.5	11650	21" x 17" x 21"	60 lbs.
GBS-16-S-4.8	911-1020	16"	4.8	12616	21" x 17" x 21"	72 lbs.
GBS-18-S-5.5	911-1022	18"	5.5	14200	22" x 18" x 22"	76 lbs.
GBS-18-S-5.5	911-1023	18"	5.5	14200	22" x 18" x 22"	76 lbs.



Clip on Duct Hose Adapter PART 725-177

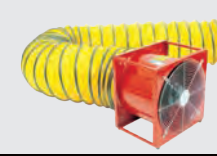

*Flex Tube Ducting Available 15' PART 725-029 25' PART 725-016

LEADER®: MT 215L, 240 & 236 NEO: GASOLINE DRIVEN FANS



13,690 to 21,355 CFM

Outstanding R&D and design have greatly increased air movement efficiency with NEO technology. Other changes in design result in greatly improved stability and ease of use. The same revolutionary concepts are used in the MT236 NEO which now returns over 30,400 CFM

Model No.	Part No.	Size	HP	CFM	Dimensions (W x D x H)	Weight
MT215L NEO	160.10.062N	18"	2.1	13690	20.9" X 20.5" X 21.9"	44 lbs.
MT236 NEO	160.10.053N	18"	4.8	19810	21.6" X 22" X 19.3"	93 lbs.
MT240 NEO	160.10.060N	18"	5.5	21355	21.6" X 22" X 19.3"	95 lbs.



The powerhouse in our mobile ventilation line, the **TEMPEST** MVU-60™ is the largest units we manufacture. The combined massive 60" (1.5 meters) seven (7) blade aluminum impeller and steel shroud are capable of generating air movement unlike any other ventilation unit around. At a calculated 400,000 nominal CFM (679,604 m³/hr), the Mobile Ventilation Unit 60 will ventilate nearly anything caught downwind.

All of the unit's mechanical actions, including the fan's blade rotation, are powered by its extremely reliable hydraulic system. The hydraulic pressure is generated by the powerful diesel or gasoline engines, mounted under the MVU™ silencer hood. With every square inch built to our unmatched standards, we're confident that there's no ventilation job outside the MVU-60™'s reach, whether it's a mile long tunnel or 50 story high-rise.

GENERAL SPECIFICATIONS

- Total Height: 107" (2.7 m)
- Total Width: 95" (2.4 m)
- Total Length: 197" (5 m)
- Total Weight: 13,200 lbs (6,000 kg)

BLOWER (FAN) OUTPUT

- Volume of Air:
- 400,000 Nominal CFM (679,604 m³/hr)
- Velocity of Air Stream:
- 78 - 100 MPH (35 - 45 m/s)
- Impeller RPM (Max.): 1,160

BLOWER (FAN) ASSEMBLY

- Shroud Diameter: 60" (1.5 m)
- Shroud Material: Steel
- Impeller: 7-Blades, Aluminum
- Drive: Hydraulic

ENGINE

- Cummins Diesel or Caterpillar
- 133 HP (99 kW)
- 55 Gallon (208 Liter) Fuel Tank 8 Hour Operating Time

Model No.	Part No.	Description
MVU-60	950-2002	Mobile Ventilation Unit with Hydraulic System, Tilt Device, with Wired Remote, with Engine
MVU-60	950-2014	Mobile Ventilation Unit with Hydraulic System, Tilt Device, with Wired Remote, without Engine - PTO Driven
MVU-60	950-2003	Hydraulic Lowering System
MVU-60	950-2004	Electric Rotation System (360°) Device
MVU-60	950-2005	Scissor Lift 9' 10" (3m)
MVU-60	950-2007	Water Misting System
MVU-60	950-2029	MVU-60™ Trailer - 20 Foot - with "Pintle" Hitch
MVU-60	950-7180	Flex Tube Ducting for Suction/Pressure - 60" x 10' Long, 4" Pitch, Yellow
MVU-60	950-7181	MVU-60™ Flex Tube Ducting Adapter

OPTIONAL FEATURES

The MVU-60™ proudly offers a number of options in addition to its standard features that are designed to help you overcome any unique challenges you may face in your specific application. From ventilator lift, to rotation, to a high volume water misting system, these options give you the power to pick and choose exactly what you need to ensure you're properly equipped to ventilate effectively and efficiently.



- FIXED PANEL CONTROLS**
- Engine/Fan RPM
 - Gauges for Temperature/Oil Pressure
 - Hydraulic Control Pressure
 - Panel Light
 - Engine Hour Meter
 - Emergency Shut-Down Switch



- WIRED OR WIRELESS (OPTIONAL) REMOTE CONTROLS**
- Fan Action (Start/Stop)
 - Fan Tilt (Up/Down)
 - Fan Rotation (Left/Right)
 - Scissor Lift (Up/Down)
 - Emergency Stop SWitch



The **TEMPEST** MVU-48™ is a slightly scaled down version of the MVU-60™, about 4,000 lbs (1,814 kg) lighter. As the name implies, it showcases a still massive 48" (1.2 meters) seven (7) blades aluminum impeller and steel shroud. With its calculated 380,000 nominal CFM (645,624 m³/hr), the 48 is able to complete any ventilation job in a few minutes saving precious time, money, resources and lives. Although it's smaller than the MVU-60™, it sacrifices almost none of the performance to achieve its reduced weight and



GENERAL SPECIFICATIONS

- Total Height: 95" (2.4 m)
- Total Width: 75" (1.9 m)
- Total Length: 177" (4.2 m)
- Total Weight: 8,800 lbs (4,000 kg)

BLOWER (FAN) OUTPUT

- Volume of Air:
- 380,000 Nominal CFM (645,624 m³/hr)
- Velocity of Air Stream:
- 78 - 94 MPH (31 - 42 m/s)
- Impeller RPM (Max.): 1,450



FIXED PANEL CONTROLS

- Engine/Fan RPM
- Gauges for Temperature/Oil Pressure
- Hydraulic Control Pressure
- Panel Light
- Engine Hour Meter
- Emergency Shut-Down Switch



WIRED OR WIRELESS (OPTIONAL) REMOTE CONTROLS

- Fan Action (Start/Stop)
- Fan Tilt (Up/Down)
- Fan Rotation (Left/Right)
- Scissor Lift (Up/Down)
- Emergency Stop Switch

more compact size.

Like the MVU-60™, all of the 48's mechanical actions, including the fan's blade rotation, are powered by a reliable hydraulic system. The hydraulic pressures are generated by its turbo charged engine, mounted under the MVU's™ silencer hood. Every MVU-48™ is custom built by our team of engineers and fabricators.



BLOWER (FAN) ASSEMBLY

- Shroud Diameter: 48" (1.2 m)
- Shroud Material: Steel
- Impeller: 7-Blades, Aluminum
- Drive: Hydraulic

ENGINE

- Cummins Diesel or Caterpillar
- 133 HP (99 kW)
- 55 Gallon (208 Liter) Fuel Tank 8 Hour Operating Time

Model No.	Part No.	Description
MVU-48	950-2001	Mobile Ventilation Unit with Hydraulic System, Tilt Device, with Wired Remote, with Engine
MVU-48	950-2013	Mobile Ventilation Unit with Hydraulic System, Tilt Device, with Wired Remote, without Engine - PTO Driven
MVU-48	950-2003	Hydraulic Lowering System
MVU-48	950-2004	Electric Rotation System (360°) Device
MVU-48	950-2005	Scissor Lift 9' 10" (3m)
MVU-48	950-2007	Water Misting System
MVU-48	950-2029	MVU-48™ Trailer - 20 Foot - with "Pintle" Hitch
MVU-48	950-7190	Flex Tube Ducting for Suction/Pressure - 48" x 10' Long, 4" Pitch, Yellow
MVU-48	950-7191	MVU-48™ Flex Tube Ducting Adapter

OPTIONAL FEATURES

The MVU-48™ proudly offers a number of options in addition to its standard features that are designed to help you overcome any unique challenges you may face in your specific application. From ventilator lift to rotation, to a high volume water misting system, these options give you the power to pick and choose exactly what you need to ensure you're properly equipped to ventilate effectively and efficiently.



LEADER® EASY 4000

MOBILE LARGE-VOLUME VENTILATION SYSTEM

The **LEADER** 4000 is a very effective solution for smoke removal and air cooling and renewal in large spaces (parking lots, large building, apartment blocks, factories, storage facilities, exhibition venues, etc.)

Very Powerful Airflow: 235,430 CFM

Very stable and extremely light for easy deployment.

Unrivalled combination of performance and maneuverability,

Large 47.2 inch diameter shroud with -10° to +20° tilt controlled from the control panel.

With water or water+additive(s) misting system:

- 65 GPM @ 100 PSI
- Range up to 197 ft.

235,430 CFM



POSSIBLE CONFIGURATIONS:

Trailer Mounted

- One person can easily position the trailer
- Total maximum weight less than 1600 lbs: Can be pulled by a light vehicle.

Skid Mounted

- For installation on bed or vehicle (pick-up, truck, railroad-going platform, etc.)

CHARACTERISTICS

MODEL	Skid EASY 4000		
Lift System	Without	23.6 inch	47.2 inch
References	I60.30.110	I60.30.111	I60.30.112
OPEN AIR FLOW	234,430 CFM		
Nominal Air Flow	108,890 CFM		
Propeller Diameter	47.2 inch		
Height - inch	63.7	70.4 to 94.1	75.7 to 122.9
Width - inch	58	58	58
Length - inch	71.2	71.2	71.2
Weight - lbs dry	820.1	1,042.8	1,142
Weight - lbs in running mode	892.9	1,115.5	1,214.7
Mounting	Steel chassis painted in black epoxy (all delivered on pallet)		

Engine control panel	Mounted on support (steel painted in red epoxy) Protective cover supplied / Ingress protection: IP55 <input type="checkbox"/> engine start and stop <input type="checkbox"/> tilt of shroud from -10° to +20° <input type="checkbox"/> airflow by adjusting the fan speed <input type="checkbox"/> raising and lowering the lifting table depending on selected option <input type="checkbox"/> emergency simultaneous engine stop, tilt and/or table rise
Misting system	For water or water+additive(s) – 65 GPM @ 100 PSI — Inlet supply 1.5 inch NST
Engine	BMW Flat Twin - 1170 cm3 with electronic control Electric start – Fuel consumption: 25 L/hour at full speed - Cooling: Air/Oil
Engine Power	115 HP – 2 cylinders – 4-stroke
Tank	11 Gallon
Fuel	unleaded gasoline 95
Runtime	1h40 min
Oil	Engine oil: 1 gal – API SL / Hydraulic oil for raising table option: 0.2 gal – ISO32
Battery	Rapid charge 12V / 15 Ah battery to power the electrical equipment
Noise level	96 dB at 23 ft
Use	PPV
Application	Ventilating underground parking lots, industrial sites, warehouses, tunnels, high rise buildings, etc.

OPTIONAL ACCESSORIES:

U.S. Trailer for Easy 2000/4000 (No Rotation)	No Rotation 84" X 120"	A6D.30.134
U.S. Trailer for Easy 2000/4000 (with Rotation)	With Rotation 84" X 120"	A6D.30.133
Wired remote control	Control from up to 42.6 ft away: <input type="checkbox"/> the tilt of the shroud from -10° to +20° <input type="checkbox"/> airflow by adjusting the fan speed <input type="checkbox"/> raising and lowering the lifting table depending on selected option <input type="checkbox"/> engine stop	I60.30.118
Manual 360° rotation system	For Skid version only. Add +6.9 inch height and +154.3 lbs	I60.30.010
Exhaust extension	L 8.2 ft / Ø 3.1 inch	I60.30.003
Adapter for exhaust extension	For connecting the exhaust extension	I60.30.017
Blowing duct	For channeling the air stream of the EASY 4000 in a straight line L 39.4 ft – Ø 5.6 ft – Outlet cross section 3.6 ft – 88.2 lbs	I60.30.016
Extraction duct	Up to 6 ducts can be interconnected on both side of the engine. 1 duct = Ø 22.6 inch / L 19.7 ft / 41.9 lbs	I60.30.019



LEADER® EASY 2000

129,400 CFM



CHARACTERISTICS

MODEL	Skid EASY 2000		
Lift System	Without	23.6 inch	47.2 inch
References	160.30.121	160.30.125	160.30.126
OPEN AIR FLOW			
		129,400 CFM	
Propeller Diameter		34.8 inch	
Height - inch	49.2	59.5	64.8
Width - inch	41.7	41.7	41.7
Length - inch	47.4	50.5	50.5
Weight - lbs dry	348.3	659.4	758.4
Weight - lbs in running mode	392.4	703.4	802.5
Mounting	Skid on red epoxy-painted steel chassis adaptable to bed of trailer, pick-up, truck, etc. (all delivered on pallet)		

Engine control panel	Mounted on the engine. Allows the operator to control: <ul style="list-style-type: none"> <input type="checkbox"/> the starter <input type="checkbox"/> electrical start/stop <input type="checkbox"/> fan flow rate via the accelerator <input type="checkbox"/> rpm and hour-run time via the hour meter <input type="checkbox"/> oil level (warning light)
Wired remote control	Control, from as far as 33 ft away: <ul style="list-style-type: none"> <input type="checkbox"/> the tilt of the shroud from -10° to +20° <input type="checkbox"/> the rise and fall of the lifting table depending on the selected option <input type="checkbox"/> engine stop <input type="checkbox"/> turn LED spotlight on/off
Misting system	For water or water+additive(s) – 65 GPM @ 100 PSI
Engine	HONDA GX630
Engine Power	20.8 HP
Tank	4.8 Gallon
Fuel	unleaded gasoline 95
Runtime	3h05 min
Oil	Engine oil: 5W-30 synthetic API SJ or later (CASTROL MAGNATEC) Hydraulic oil for lifting option: CASTROL SAF XJ 75-140
Battery	12V / 44 Ah battery to power the electrical equipment
Noise level	93.9 dB at 23 ft
Use	PPV
Application	Ventilating underground parking lots, industrial sites, warehouses, tunnels, etc.

OPTIONAL ACCESSORIES:

U.S. Trailer for Easy 2000/4000 (No Rotation)	No Rotation 84" X 120"	A6D.30.134
U.S. Trailer for Easy 2000/4000 (with Rotation)	With Rotation 84" X 120"	A6D.30.133
Manual 360° rotation system	For Skid version only. Add +10.4 inch height and +154.3 lbs	160.30.129
Exhaust extension	L 8.2 ft / Ø 2 inch Tip: use 3 exhaust extensions end to end for more efficiency	160.20.012
Adapter for exhaust extension	For connecting the exhaust extension	160.30.128
Trolley	Aluminum trolley with handle and brake system for easy movement of the Skid EASY 2000 (without lift system)	160.30.119
Blowing duct	16.4 ft / Ø 35.4 inch	160.30.122
Suction duct	up to 6 ducts can be interconnected on one side of the engine. 1 duct Ø 22.6 inch / L = 19,7 ft / 41,9 lbs	160.30.019

MOBILE LARGE-VOLUME VENTILATION SYSTEM

The **LEADER** 2000 is the most powerful large-flow ventilator in its category for smoke removal and cooling in large volumes (covered / closed parking lots, warehouses production line, exhibition halls, etc..)

Very powerful airflow: 129,400 CFM

Extremely light weight for ease of deployment.

- Less than 397 lbs for the skid version
- Less than 716 lbs for the trailer version

A motor control panel and a wired remote control for tilt, elevation and lighting according to selected options.

Two possible elevation platforms (23.6 inch or 47.2 inch) on lifting table controlled by wired remote control

Electric tilt of shroud from -10° to +20° controlled by wired remote control.

POSSIBLE CONFIGURATIONS:

Trailer Mounted

- movable and usable with forklift truck
- mounted on trolley or similar
- can be mounted on bed of vehicle, e.g. pickup truck

Skid Mounted

- For installation on bed or vehicle (pick-up, truck, railroad-going platform, etc.)

FIRE RESCUE CHAINSAWS



Our 565-HD and 572-HD fire rescue chainsaws deliver the absolute best in cutting performance, built specifically for the fire service. Using professional level Husqvarna® power heads and **TEMPEST** exclusive after-market parts, no other saw compares.

Model No.	Part No.	Description	Bar	HP	Pitch
572HD-16-DG.404	TV400-081	Chain, Depth Gauge	16"		
572HD-16.404	TV400-084	Chain, No Depth Gauge	16"	5.8	0.404
572HD-20-DG.404	TV400-080	Chain, Depth Gauge	20"		
572HD-20.404	TV400-083	Chain, No Depth Gauge	20"		
572HD-16-DG.404	TV400-086	No Chain, Depth Gauge	16"		
572HD-16.404	TV400-088	Chain, No Depth Gauge	16"	5.8	0.404
572HD-20-DG.404	TV400-085	Chain, Depth Gauge	20"		
572HD-20.404	TV400-087	Chain, No Depth Gauge	20"		
565HD-16-DG.404	TV400-031	Chain, Depth Gauge	16"		
565HD-16.404	TV400-033	Chain, No Depth Gauge	16"	5	0.404
565HD-20-DG.404	TV400-030	Chain, Depth Gauge	20"		
565HD-20.404	TV400-032	Chain, No Depth Gauge	20"		

FIRE RESCUE CUTOFF SAWS



Ventmaster® Fire Rescue Cutoff Saws provide a number of features you will only find with **TEMPEST** including a patented depth gauge and roller assembly. Built on professional grade Husqvarna® power heads, these saws deliver only the best in cutting performance.

Model No.	Part No.	Description	Dia.	HP
375K-DG (K770)	TV406-506A	with Depth Gauge	14"	5.0
375K (K770)	TV406-606A	No Depth Gauge		
397K-DG (K970)	TV406-507A	with Depth Gauge	14"	6.5
397K (K970)	TV406-607A	No Depth Gauge		
3120K-DG (K1270)	TV406-508A	with Depth Gauge	14"	7.8
3120K (K1270)	TV406-608A	No Depth Gauge		

AVAILABLE OPTIONS:

- Depth Gauge
- Optional 16" or 20" Bars
- All Cut Rescue Diamond Blade
- Ventmaster™ Diamond Blade
- Concrete Diamond Blade
- Ductile Iron Diamond Blade

BATTERY-POWERED SAWS



535i XP Battery Chainsaw



K970i Battery Concrete Chainsaw



K535i Battery Cutoff Saw

Model No.	Part No.	Diameter/Bar Size
Chain Saw Kit - Husqvarna 535iXP	TV402-025	14"
Chain Saw Kit - Husqvarna 540iXP	TV402-027	16"
Cut Off Saw Kit - Husqvarna 535iXP	TV402-075	9"

PATHMASTER® SMOKE CURTAIN

Pathmaster® from **TEMPEST** puts fire movement/growth control in a fire department's hands. Pathmaster® creates a temporary blockade, almost entirely eliminating smoke spread and movement between rooms.

PATHmaster SMOKE CURTAIN keeps escape routes such as stairwells free from blinding and suffocating smoke. Significantly helps to prevent unnecessary smoke risk/damage, saving property. Allows a firefighter to easily open and close flow paths.

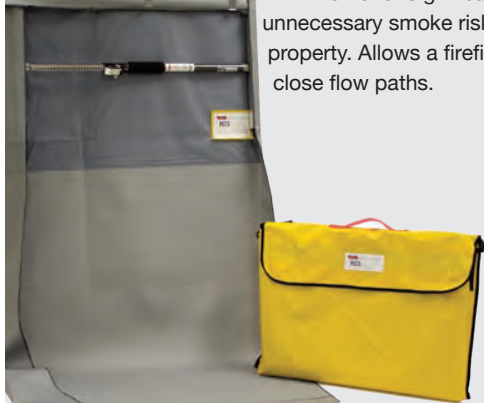

Fire resistant to 1100° F (600° C)

Model No.	Part No.	Description
Pathmaster®	715-001	Smoke Curtain Regular - 28" - 46" Width
Pathmaster®	715-002	Smoke Curtain XL - 36" - 59" Width

SMOKE MACHINES

Our smoke generators can produce dense and realistic smoke, creating ideal circumstances for training in safe conditions. They respond perfectly to different firefighting training requirements by filling small and large rooms in a few seconds.



Model No.	Part No.	Capacity
Dusk (110V)	710-401	1 liter/hr.
Dusk (220V)	710-404	1 liter/hr.
Smoke 3 (110V)	710-430	5.3 liter/hr.
Smoke 3 (220V)	710-435	5.3 liter/hr.
Smoke 5 (110V)	710-431	10.5 liter/hr.
Smoke 5 (220V)	710-436	10.5 liter/hr.

AVAILABLE OPTIONS:
Smoke Fluid available in Liter containers and drums

FIRE TRAINERS/FLAME GENERATORS

Specially designed for fire safety trainers, the **LEADER** range of fire training equipment enables you to organize realistic and dynamic exercises corresponding to different emergency situations when a fire breaks out. These stainless-steel Flame Generators run on propane gas. With or without water, they produce powerful, hot flames with controllable height from 0.5 ft to 10 ft. depending on the model.



GF42

AEROS 2

PYROS 3

COMPACT & LIGHTWEIGHT

- Easy to transport
- Quick to set up
- Simple to use

COMPACT FOR POWERFUL FLAMES

- Easy to transport
- Impressive oil-slick fire effect

AVAILABLE OPTIONS:
Screens, Bins, Oil Explosion modules, Aerosol Can modules and other realistic options available

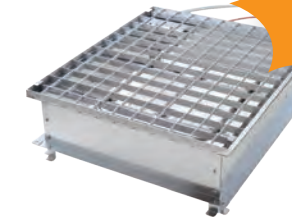

Without water
Surface area of fire: 4.5 ft²
Flame height: up to 4 ft.



Volume of water: 9 gal
Surface area of fire: 5.5 ft²
Flame height: up to 5 ft.

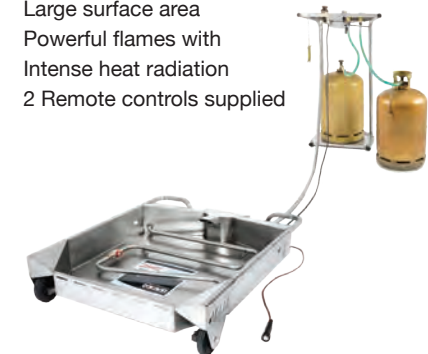

Volume of water: 16 gal
Surface area of fire: 9ft²
Flame height: up to 10ft.

Model No.	Part No.	Description
GF42	V90.00.038K	GF42 Environmentally-Friendly Flame Generator

Model No.	Part No.	Description
AEROS	V90.00.036K	Aeros2 Environmentally-Friendly Flame Generator

Model No.	Part No.	Description
PYROS3	V90.00.041K	Pyros3 Environmentally-Friendly Flame Generator

FIREFIGHTING FOAM PROPORTIONING SYSTEMS

LEADER MIX: AUTONOMOUS & AUTOMATIC FOAM PROPORTIONER

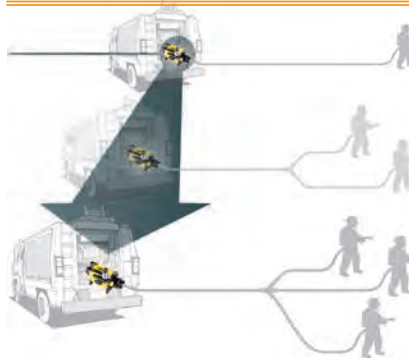

ONE INDUCTOR FOR ALL FLOWS/ CLASS A & B FOAM

AUTOMATIC, AUTONOMOUS & RELIABLE INDUCTOR:

- Require no power supply / no electronics
- Reduced maintenance

LARGE RANGE OF USE

- Replaces 4 conventional inductors (60, 95, 125, 250)
- Wide range of flow rates from 50-500 gpm (190-1892 lpm)
- Wide operating pressure range from 75 - 230 PSI (5 - 16 Bar)

ACCURATE METERING & REDUCED CONSUMPTION

- Accurate metering of foam concentrates from 0.3% to 6%
- Adapts automatically to selected flow rate at the nozzle

CREATE SUCTION EACH TIME FOAM IS REQUIRED

- Even works at 75 PSI (4 Bar)

2 VERSIONS AVAILABLE:

- Vehicle Mounted
- Portable



Model No.	Part No.	Description
Leader Mix AR - Portable	140.90.118	50 to 275 GPM from 0.3% to 3% (50 to 135 GPM at 6%) - Inlet and Outlet 2.5" NH F/M
Leader Mix AR - Vehicle Mounted Automatic Dosing System with Control Panel	140.90.119	50 to 275 GPM from 0.3% to 3% (50 to 135 GPM at 6%) - Inlet and Outlet 2.5" NH F/M
Leader Mix Class A - Vehicle Mounted Automatic Dosing System with Control Panel	140.90.121	50 to 275 GPM from 0.3% to 1% - Inlet and Outlet 2.5" NH F/M
Leader Mix AR - Portable Automatic Dosing System with Control Panel	140.90.218	80 - 500 GPM from 0.3% to 3% (80 - 250 GPM at 6%) - Inlet and Outlet 4" NPT F/F
Leader Mix AR - Vehicle Mounted Automatic Dosing System with Control Panel	140.90.208	80 - 500 GPM from 0.3% to 3% (80 - 250 GPM at 6%) - Inlet and Outlet 4" NPT F/F

ROBWEEN PUMP 125 & 180



CENTRIFUGAL PUMP DESIGNED FOR SMALL FIREFIGHTING TRUCKS, SKIDS...

2 VERSIONS AVAILABLE :

- **Model 125:** 70 gpm (265 lpm) at 100 PSI (7 Bar)
- **Model 180 :** 120 gpm (455 lpm) at 100 PSI (7 Bar)

3 CONFIGURATIONS:

- Complete: Pump + guard + belt + engine (18HP or 13HP)
- Pump + guard and belt
- Pump alone

UPRIM: PORTABLE FOAM UNIT

A COMPACT AND CONSTANTLY READY-TO USE FOAM FIRE-FIGHTING MEANS

MODELS:

- Interchangeable Low Expansion and Medium Expansion nozzles via quick connection

FLOW RATE : 15 gpm (56 lpm)

CONCENTRATION: 1%, 3% and 6%

CAPACITY: 2.6 gallon / 10 Liter



ROBWEEN FLOWMIX: BLADDER TANK INDUCTOR FOR VARIABLE FLOWS

FOR THE STORAGE AND INJECTION OF CLASS A FOAMS.

MAIN CHARACTERISTICS:

- Flow range: 5 - 500 gpm (20 - 1895 lpm)
- Dosing: 0.1 to 3%
- Service pressure: 20 - 435 PSI (1.5 - 30 Bar)
- Foam tank: 5 - 10 Gal (20 - 40 ltr)

NO ELECTRONICS

EASY MAINTENANCE



Model No.	Part No.	Description
Flowmix	ROB-500P-BSP	500P-BSP Portable Foam System
	ROB-500P-NST-A	500P-NST-A Portable Foam System
	ROB-500B-BSP-A	500B-BSP-A Built In Foam System
	ROB-500B-LFNPT	500B-LFNPT Built In Foam System
	ROB-500B-LFNST	500B-LFNST Built In Foam System
	ROB-500B-NPT	500B-NPT Built In Foam System

Essential tool in use with additives of class a fires where the concentration usage is very low (0.1 To 0.6%)

- Operations in urban and industrial fires: Wood, Paper, Carton, Plastic, Rubber, Tissues, Textiles,
- Vegetation, Brush ...
- Forest fire responses

Model No.	Part No.	Description
Flowmix	ROB-500B-VICNPT	500B-VICNPT Built In Foam System
	ROB-500B-VIC-A	500B-VIC-A Built In Foam System
	ROB-500P-LFNST	500P-LFNST Portable Foam System
	ROB-750P-BSP-A	750P-BSP-A Portable Foam System
	ROB-1000P-BSP	1000P-BSP Portable Foam System
	ROB-1000B-BSP	1000B-BSP Built In Foam System

FIREFIGHTING NOZZLES

SMOOTH BORE NOZZLE

MAIN CHARACTERISTICS:

- Tips available: 3/4", 15/16", and more.
- NPSH F Threads Available



Model No.	Part No.	Description
	SBA-60-R	Smooth Bore Aluminum Tip - 3/4" - 1.5" NH F
	SBA-61-RI	Smooth Bore Aluminum Tip - 15/16" - 1.5" NH F
	SBA-61-SI	Smooth Bore Aluminum Tip - 7/8" - 1.5" NH F
	SBA-62-RI	Smooth Bore Aluminum Tip - 1.0" - 1.5" NH F
Smooth Bore	LSBA-0502-R6R	Ball Valve for Smooth Bore - Aluminum - Inlet 1.5" NH F - Outlet 1.5" NH M
Smooth Bore	LSBA-0502-S6R	Ball Valve for Smooth Bore - Aluminum - Inlet 2.5" NH F - Outlet 1.5" NH M
Smooth Bore	LSBA-0520-RIR	Smooth Bore Nozzle - Large Body - With 15/16" Tip - Inlet 1.5" NH F
Smooth Bore	LSBA-0520-SIR	Smooth Bore Nozzle - Large Body - With 15/16" Tip - Inlet 2.5" NH F

ONEFLOW NOZZLE

MAIN CHARACTERISTICS:

- With or without turbine



Model No.	Part No.	Description
One Flow	ROFA-0529-RIR	One Flow 150GPM 1.5" NH without turbine
One Flow	ROFA-0729-RIR	One Flow 150GPM 1.5" NH with turbine

2 SERIES : ALUMINUM OR FiberTech® COMPOSITE

CHOOSE FROM OUR RANGE TO CREATE CONFIGURATIONS APPROPRIATE TO YOUR FIRE MISSIONS

MULTIFLOW NOZZLE

SELECTABLE FOAM NOZZLE

100PSI (6 BAR)

Slide valve nozzles with Slide valve nozzles with large ring for selecting flow rate and flush



Flow Rate GPM / (LPM)	Size	Nozzle Body	Pressure	Weight	Inlet
5-40 / (20-150)	Compact	Aluminum	100 PSI (7 Bar)	3.85 lbs.	1" NH F
		Aluminum		3.85 lbs.	1.5" NH F
30-125 / (115-475)	Regular	Aluminum	100 PSI (7 Bar)	4.8 lbs.	1.5" NPSH F
		FiberTech®		4.8 lbs.	1.5" NPSH F
30-150 / (570)	Large	Aluminum	100 PSI (7 Bar)	4.8 lbs.	1.5" NH F
		FiberTech®			1.5" NPSH F
		Aluminum			1.5" NPSH F
		Aluminum			1.5" NPSH F
95-200 / (360-760)	Large	Aluminum	100 PSI (7 Bar)	7.3 lbs.	1.5" NPSH F
95-200 / (360-760)				7.4 lbs.	2.5" CSA
125-250 / (475-950)					2.5" NH F

FLOWMATIC NOZZLE

AUTOMATIC FOAM NOZZLES

100PSI (6 BAR)

Slide valve nozzles with pressure regulating system. optimum jet pattern at all times optimized reach



Flow Rate GPM / (LPM)	Size	Nozzle Body	Pressure	Weight	Inlet
0-125 / (0-475)	Compact	Aluminum	100 PSI (7 Bar)	3.85 lbs.	1.5" NPSH F
		Aluminum	100 PSI (7 Bar)	3.85 lbs.	1.5" NH F
0-150 / (0-570)	Regular	FiberTech®	75 PSI (5 Bar)	4.8 lbs.	1.5" NPSH F
		Aluminum	75 PSI (5 Bar)	4.8 lbs.	1.5" NH F
0-150 / (0-570)	Regular	Aluminum	100 PSI (7 Bar)	4.4 lbs.	1.5" NPSH F
		Aluminum			1.5" NH F
		FiberTech®			1.5" NPSH F

TWIN ACTION NOZZLE



MULTIFUNCTIONAL FOAM NOZZLE

- Body made of FiberTech® composite material for anti-corrosion
- Sliding ring for selecting water / foam position
- Expansion by approximately x10 when supplied with pre-mix (outlet ring).
- Change from straight Jet to diffused jet by head rotation.
- Ball valve
- Swivel Inlet
- Flow Rate: Up to 60 gpm (227 lpm) @ 100 PSI (7 Bar)
- Weight 3.3 lbs.
- NPSH Threads Available

EXPANDER NOZZLE



LOW EXPANSION FOAM NOZZLE

- Nozzle made of FiberTech® composite
- Corrosion-proof with hard anodized aluminum polyester lined cylinder
- Ball valve
- Swivel Inlet
- Expansion x10
- Flow Rates: 60 or 95 (225 or 360)
- Lengths: 13.4 Inches (60 and 85 gpm)
- Optimized ranges: 102 ft. (60 gpm) / 110 ft (95 gpm)
- Weight: 3.74 lbs. (60 and 95 gpm)
- NPSH Threads Available

PIERCING NOZZLE



SAFELY ATTACK A FIRE FROM OUTSIDE

- Nozzle made of FiberTech® composite Corrosion-proof with hard anodized aluminum polyester lined cylinder
- Ball valve
- Swivel Inlet
- Expansion x10
- Flow Rates: 60 or 95 (225 or 360)
- Lengths: 13.4 Inches (60 and 85 gpm)
- Optimized ranges: 102 ft. (60 gpm) / 110 ft (95 gpm)
- Weight: 3.74 lbs. (60 and 95 gpm)
- NPSH Threads Available

LEADER® MIX 60G / 95G

HIGH PRECISION VENTURI INDUCTORS / PROPORTIONERS

Body and dosing knob made of **FiberTech®** composite material

- Lower weight
- Anti-corrosion



- Concentration proportioning: 0.5%, 1%, 3% and 6%
- Flow Rate: 60 or 95 gpm (227 or 360 lpm) at 100 PSI (7 Bar)
- Suction flexible hose 4.9ft+ pick up tube 3.3 fl long
- Relief ball valve
- Stainless steel screws & axis
- 1.5" NH F Inlet 11.5" NH M outlet
- NPSH Couplings Available

PORTABLE MONITOR NOZZLES

ONEFLOW

Fixed Flow Monitor Nozzle

- Ref: CDA-026-SI: 350 GPM @ 100PSI
- Ref: CDA-027-SI: 500 GPM @ 100PSI
- Ref: CDA-028-SI: 750 GPM @ 100PSI



FLOWMATIC

Automatic Monitor Nozzle

- Ref: CDA-020-SI: 500 GPM @ 100PSI
- Ref: CDA-022-SI: 750 GPM @ 100PSI



LEADER® MULTISEARCH

LEADER MULTISEARCH IS 1 SINGLE CONTROL BOX TO CONNECT TO THE FOLLOWING PERIPHERALS FOR USE 1BY1:

MS BOX MULTISEARCH Control Box
(Allows Scalability) with Microphone/Speaker Headset

Radar Movement Detector
SCAN

Listening Seismic Sensors
SEARCH

Search Color Camera
CAM

Thermal Imaging Camera
TIC

Camera and Seismic Wireless Sensors
HASTY

Radar Movement Detector Sensor

Wireless Seismic Sensors x2 or x3

Color Camera Head + Telescopic Pole

Thermal Imaging Camera Head Alone

Camera Head + Wireless Sensors

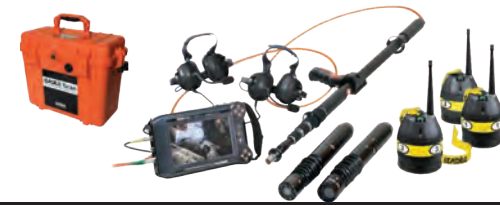

- 2-in-1 search device
- Fast deployment
- Compact and lightweight
- Ergonomic control box
- Intuitive navigation interface and menu
- Extra-wide color screen

- Ultra-lightweight 12ft. (3.7 meters) telescopic pole.
- Up to 3 wireless seismic sensors, each with a range of 330 ft.
- Position of camera shown on screen

VECTOR 2: PORTABLE MONITOR

PORTABLE GROUNDS MONITOR EN15-767 CERTIFIED

- Flow Rate: Up to 1250 gpm @ 100PSI
- Base has safety shutoff in case of movement and protected pressure gauge.
- Turret is equipped with large handle and hand wheels for elevation and rotation adjustment
- High elevation up to 85° (from 25°)
- Rotation from 120° left to 80° right
- Automatic draining valve
- CSA Threads available



PARTNER 2: PORTABLE MONITOR

ERGONOMICALLY DESIGNED FOR PERFORMANCE, EASE OF HANDLING AND SAFETY AT THE FIRE SCENE

- Flowrate: 500 or 750 gpm @ 100 PSI (1890 or 2840 lpm @ 7 Bar)
- High elevation up to 85° (from 25°)
- Safety valve: reduces but doesn't stop the flow to keep enough flow for food protection for the firefighter and reduces water hammer
- Horizontal Operation -20° to +20°
- Equipped with a protected pressure gauge
- 5 Flexible stainless-steel legs
- Full time swivel Inlet 2.5" NH
- Quick deployment (minimal setup).
- Safety strap supplied
- Compact size in folded position: Easy vehicle storage
- Very low maintenance
- CSA Threads Available



LEADER® MULTISEARCH: HASTY

CAMERA HEAD AND WIRELESS SEISMIC SENSORS - IDEAL FOR USAR OPERATIONS



- Leader HASTY - Life detectors / Locators
- Combined listening/viewing tool.
- The only 2 in 1 device that combines wireless seismic detection and a search camera.
- 12ft. (3.7 meters) Telescopic Pole

LEADER® MULTISEARCH: SEARCH

SEISMIC DETECTOR WITH WIRELESS AND/OR WIRED SEISMIC SENSOR



- Compact and lightweight
- WIRELESS technology for fast set up and ease of movement; no more cables caught in debris.
- 1 - 6 connectible seismic sensors
- Up to 3 wireless sensors, each with a range of 330 feet
- Up to 3 wired sensors, each with 26 feet of cable

LEADER® MULTISEARCH: CAM

SEARCH CAMERA WITH BUILT-IN COMMUNICATION SYSTEM



- Position of camera shown on screen
- Compact and lightweight
- Ergonomic control box
- Intuitive navigation interface and menu
- Extra-wide color screen
- Ultra-lightweight telescopic pole:
- Two Options: extending to 6.5ft or 13ft
- Law Enforcement Black Case option available

LEADER® WASP

WARNING ALARM FOR STABILITY PROTECTION

- Portable/lightweight & rapid deployment
- User programmable SMART functions
- Configurable Alarm Settings
- Attach to any surface
- High Impact-resistant composite body.



Model No.	Part No.
WASP Single	D11.06.030
WASP Double	D11.06.031

LEADER® VOLT:

AC CURRENT DETECTOR

- Detects unknown sources of AC voltages
- Safe and easy to use, Water resistant
- High sensitivity

LEADER® SENTRY WIRELESS

MONITORS UNSTABLE STRUCTURES TO ALERT FIRE & RESCUE TEAMS OF POTENTIAL COLLAPSE RISK.

- 2 laser beams can operate simultaneously
- Full Control at each laser head
- Weight <4.4 lbs.
- Range: 164 feet (up to 1 mm precision)
- 105 dB Alarm & Flashing Light
- 8h running time
- 328ft range between each laser/remote control
- Optional battery for 45 hour run time.



*single or double available

Model No.	Part No.	Description
Sentry Full Kit	D11.06.020F	Sentry Full Kit - Single Beam
Sentry Full Kit	D11.06.022F	Sentry Full Kit - Dual Beam

LEADER® COM CONFINED SPACE COMMUNICATIONS

EFFECTIVE COMMUNICATIONS IN ALL EXTREME SITUATIONS

- Hands-free operation
- Simple hardware
- Superior sound quality
- NFPA-Approved communication safety rope
- MSHA-Approved comms cable system
- Connects 2 - 10 people
- 3 mile range per user
- Attendant-free system
- Waterproof connectors tested to 33 ft
- 200 hours of operation on 3 AA batteries



Monitor Nozzle: Automatic or Fixed Flow

Model No.	Weight	Part No.
Base 2x2.5" NH F	25.1 lbs.	CPA-210-SI
Turret 2.5" NH M	24.9 lbs.	CPA-310-I5

Model No.	Part No.
Partner	CPA-022-S5
Oscillating Partner 2	CPA-122-S5

DECISION-MAKING THERMAL IMAGING CAMERAS

3.1 OR 4.1 THERMAL IMAGING CAMERAS (1 BUTTON VERSION)

EFFICIENT= 1 BUTTON FOR EASE OF USE

High resolution thermal imaging decision-making camera with 3.5" or 4" screen.

COMPACT

- **TIC 3.1** (6.5" x 5.5" x 3.4")
- **TIC 4.1** (6.6" x 5.7" x 3.8")

LIGHTWEIGHT (with 2 batteries)

- **TIC 3.1** - 2.05 lbs
- **TIC 4.1** - 2.1 lbs

LARGE DISPLAY SCREEN FOR DETAILED VISIBILITY

- **TIC 3.1** - 3.5" screen / **TIC 4.1** - 4" screen

BENEFITS

- **Industry's widest temperature range:** -40° to 2100°F (-40° to 1150°C)
- Video, photo and still image recording
- Safe batteries (LiFePO4): for high temp conditions
- Germanium window to protect the optics < 5 sec Bootup Time
- Wireless video transmission: Live video can be sent to a computer, tablet or smartphone thanks to optional wireless stick (WLAN module)
- Zoom: x2 - x4
- Continuous operation by changing one battery during use (no need for power off the camera)
- Optional pistol-type handle

1 COLOR MODE FOR EASE OF USE

- Fire Coloring mode is standard
- Optional Search coloring mode available.

WARRANTY:

- 5 years for the camera.
- 6 years for batteries (5000 charge cycles)
- 10 years for warranty sensor

OPTIONS

- Available in NFPA-Rated or non-NFPA options



Wireless video transmission kit (option): Stream Live Video up to 3 remote devices simultaneously (mobile, tablet, computer).

3.3 OR 4.3: THERMAL IMAGING CAMERAS (3 BUTTON VERSION)

EFFICIENT AND VERSATILE= 3 BUTTONS

High resolution thermal imaging decision-making camera with 3.5" or 4" screen.

COMPACT

- **TIC 3.3** (6.5" x 5.5" x 3.4")
- **TIC 4.3** (6.6" x 5.7" x 3.8")

LIGHTWEIGHT (with 2 batteries)

- **TIC 3.3** - 2.05 lbs
- **TIC 4.3** - 2.1 lbs

LARGE DISPLAY SCREEN FOR DETAILED VISIBILITY

- **TIC 3.3** - 3.5" screen / **TIC 4.3** - 4" screen

BENEFITS

- **Industry's widest temperature range:** -40° to 2100°F (-40° to 1150°C)
- Video, photo and still image recording
- Safe batteries (LiFePO4): for high temp conditions
- Germanium window to protect the optics < 5 sec Bootup Time
- Wireless video transmission: Live video can be sent to a computer, tablet or smartphone thanks to optional wireless stick (WLAN module)
- Zoom: x2 - x4
- Continuous operation by changing one battery during use (no need for power off the camera)
- Optional pistol-type handle

smartphone thanks to optional wireless stick (WLAN module)

- Zoom: x2 - x4
- Continuous operation by changing one battery during use (no need for power off the camera)

UP TO 5 COLORIZATION MODES:

- Fire, Search, Inverse, Cold Finder, Multicolor

WARRANTY:

- 5 years for the camera.
- 6 years for batteries (5000 charge cycles)
- 10 years for warranty sensor

OPTIONS

- Available in NFPA-Rated or non-NFPA options



DECISION-MAKING THERMAL IMAGING CAMERAS

3.1 OR 4.1 LONG RANGE THERMAL IMAGING CAMERAS (SEARCH & RESCUE/LAW ENFORCEMENT)

EFFICIENT= 1 BUTTON FOR EASE OF USE

High resolution thermal imaging decision-making camera for Search and Rescue / Law Enforcement with a 3.5" or 4" screen.

LIGHTWEIGHT (with 2 batteries)

- **TIC 3.1** - 2.05 lbs
- **TIC 4.1** - 2.1 lbs

LARGE DISPLAY SCREEN FOR DETAILED VISIBILITY

- **TIC 3.1** - 3.5" screen / **TIC 4.1** - 4" screen

2 LONG-RANGE VERSIONS:

- **TIC 3.1 LR700** can identify a human at **2297ft (700 meters)**
- **TIC 4.1 LR1000** can identify a human at **3280ft (1000 meters)**

BENEFITS

- **Industry's widest temperature range:** -40° to 2100°F (-40° to 1150°C)
- 1 colorization mode for ease of use
- 1 Large button and easy to operate even with gloves
- Safe batteries LiFePO4: No explosion at high-temperature operations
- Up to 8h running time 2 batteries with Eco-Boost-System
- Germanium window to protect the optics

OPTIONS

- Picture Capture and/or video recording
- Removable Pistol grip
- Wireless transmission kit

WARRANTY:

- 5 years - Camera.
- 6 years - Batteries (5000 charge cycles)
- 10 years - Sensor



3.3 OR 4.3 LONG RANGE THERMAL IMAGING CAMERAS (SEARCH & RESCUE/LAW ENFORCEMENT)

EFFICIENT AND VERSATILE= 3 BUTTONS

High resolution thermal imaging decision-making camera for Search and Rescue / Law Enforcement with a 3.5" or 4" screen.

LIGHTWEIGHT (with 2 batteries)

- **TIC 3.3** - 2.05 lbs
- **TIC 4.3** - 2.1 lbs

LARGE DISPLAY SCREEN FOR DETAILED VISIBILITY

- **TIC 3.3** - 3.5" screen / **TIC 4.3** - 4" screen

2 LONG-RANGE VERSIONS:

- **TIC 3.3 LR700** can identify a human at **2297ft (700 meters)**
- **TIC 4.3 LR1000** can identify a human at **3280ft (1000 meters)**

UP TO 5 COLORIZATION MODES:

- Fire, Search, Inverse, Cold Finder, Multicolor

BENEFITS

- **Industry's widest temperature range:** -40° to 2100°F (-40° to 1150°C)
- Safe batteries LiFePO4: No explosion at high-temperature operations
- Up to 8h running time 2 batteries with Eco-Boost-System
- Germanium window to protect the optics

OPTIONS

- Picture Capture and/or video recording
- Removable Pistol grip
- Wireless transmission kit

WARRANTY:

- 5 years - Camera
- 6 years - Batteries (5000 charge cycles)
- 10 years - Sensor



LEADER® STOP: FIRE BLANKET (FOR SMOTHERING VEHICLE/DUMPSTER FIRES)



- Leader STOP fire blanket allows rapid intervention to prevent flash-over and spread to other vehicles / infrastructure before the arrival of firefighters.
- Made of silicone fiberglass
- Efficiently stops the release of toxic fumes
- Unfolded dimensions 17.7' x 28.25' (518 ft.²) - Storage Box 13" x 13" x 32.6"
- Weight 58 lbs.
- Easily deployed by 2 operators.

Model No.	Part No.	Description
Leader STOP	S01.01.007	Leader Stop Fire Blanket with Storage Box, 2 Pair Gloves, Instruction Panel
Leader STOP	S01.01.008	Fire Blanket with Instruction Panel only







FIREFIGHTING FOAM CONCENTRATE SELECTION GUIDE

BIOEX®

● High performance foams



APPLICATION TYPE

BIOEX FOAM CONCENTRATE	INDUCTION RATE %	 Fire Departments	 Oil & Gas Industry	 Chemical Industry	 Aviation	 Marine	 Waste Treatment	 Training	
FLUORINE-FREE FOAMS									
AR-FFF (Alcohol-Resistant Fluorine-Free Foam)	ECOPOL	3x3, 3x6, 6x6	●	●	●	●	●	-	
	ECOPOL PREMIUM	3x3, 3x6	●	●	●	-	●	-	
FFF	ECOPOL F3HC	3	-	●	-	-	-	-	
	ECOPOL A/A+	3, 6	-	-	●	-	-	-	
Class A	BIO FOR	0.1-3	●	-	-	-	●	-	
	ECOPOL F	0.1-1	●	-	-	-	-	-	
High Expansion	BIO FOAM	2-6	●	-	●	●	●	-	
Training	BIO T	1, 3, 6	-	-	-	-	-	●	
C6 FLUORINATED FOAMS <i>Our fluorinated foams are manufactured with C6 fluorosurfactants (contain no PFOS and PFOA)</i>									
AR-AFFF (Alcohol-Resistant Aqueous Film Forming Foam)	FILMOPOL	1x1, 1x3, 3x3, 3x6, 6x6	●	●	●	●	●	-	
AFFF (Aqueous Film Forming Foam)	BIOFILM	1, 3, 6	●	●	-	●	●	-	
ADDITIONAL									
Vapor suppression)	NEUTRAL PLUS	6	●	-	●	-	●	-	
Anti-foaming agent	D FOAM	1-6	●	●	●	●	●	-	

CERTIFICATIONS

<ul style="list-style-type: none"> ● ECOPOL • European standard: EN 1568 1-2-3-4 • Oil industry: GESIP, LASTFIRE • Marine: VERITAS • High expansion: APSAD R12 • Aviation: ICAO level B • Class A: CEREN Certificate, Draves test AATCC 17-2005 • GreenScreen certified\ 	<ul style="list-style-type: none"> ● ECOPOL F3HC • European standards: EN 1568-3 certified 1A fresh water & 1A sea water • Oil industry: GESIP, LASTFIRE • Marine: VERITAS 	<ul style="list-style-type: none"> ● BIO FOAM • European standards: EN 1568-1, -2 and -3 • Marine: IMO, VERITAS, SOLAS
<ul style="list-style-type: none"> ● ECOPOL PREMIUM • European standard: EN 1568 – 1 : Conform EN 1568 – 2 : Conform EN 1568 – 3 : 1A / 1A EN 1568 – 4 : 1A / 1A • Oil industry: LASTFIRE • Forest fire standard: CEREN Certificate • Marine: IMO • Certification in progress: UL 162, GESIP 	<ul style="list-style-type: none"> ● ECOPOL A/A+ • ICAO performance level B tested and certified • European standard: EN 1568-3 certified 	<ul style="list-style-type: none"> ● FILMOPOL • International standards : UL 162 • European standards: EN 1568 1-2-3-4 • Marine: IMO • Oil Industry: LASTFIRE, GESIP
	<ul style="list-style-type: none"> ● BIO FOR • European standards: EN 1568 1-2-3 • Marine: VERITAS • Forest fire standards: CEREN Certificate, Draves test AATCC 17-2005 • International standard: UL listed, NFPA 18 	<ul style="list-style-type: none"> ● BIOFILM • European standards: EN 1568-3 1A/1A • International standards : UL 162 • Aviation: ICAO B/C • Oil Industry: LASTFIRE & GESIP • Marine: IMO
	<ul style="list-style-type: none"> ● ECOPOL F • USDA Forest Service qualified QPL listed • GreenScreen certified 	

4708 North Blythe Avenue, Fresno, California 93722
 tempest.us.com • response@tempest.us.com • 800.346.2143

TEMPEST LEADER® BIOEX®
 ● Fighting for performance ● Fighting for performance ● High performance foams

SEARCH & RESCUE



USAR
RESPONSE EQUIPMENT

2018 catalogue – Up-to-date PDF version at www.LeaderNorthAmerica.com



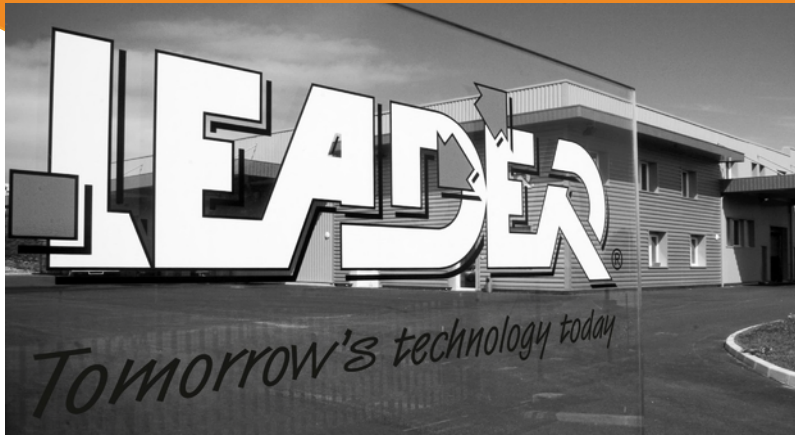

AN INTERNATIONAL PRESENCE

SUBSIDIARIES AND A STRONG NETWORK OF DISTRIBUTORS





LEADER

Since 1985, LEADER has **designed** and **manufactured** higher performing equipment used in **firefighting, fire training** and **Search & Rescue** applications and supplies them to Fire & Rescue Services, Civil Defense, Hazardous Industries, NGOs, Maritime Services, etc. on the five continents.

A major axis : INNOVATION

To meet the advancing challenges of fire hazards and search & rescue missions, equipment must continually **evolve** and **adapt** to be **more effective** while ensuring **maximum safety for workers**.

To meet these challenges, LEADER is committed to constant **innovation and new technologies** and has its own in-house **Research & Development** team which works alongside end-users to design and develop the equipment that will be available tomorrow.

To test our equipment and assess its performance, we at LEADER continually invest in our own infrastructure:

- ▶ Water and High-Expansion Foam test room (4300 ft²)
- ▶ Ventilation test room (4300 ft²)
- ▶ Victim Search Equipment test area
- ▶ Fire test area in fire container & Fire extinguishing equipment

Our commitment

When you choose LEADER equipment, you are assured of the **quality and compliance of our products**. These have been made in our workshops by our engineering and electronics **specialists**.

ISO 9001 certified since 1999, LEADER:

- ▶ Carries out **checks** at every stage of the manufacturing process as well as on the finished products before dispatch,
- ▶ Provides **continuous training** for all its staff.

Guaranteed equipment

Every LEADER product comes with a specific contractual guarantee.

Close to our customers

Through our sales force, subsidiaries in **Germany and the USA, agencies in Latin America and China and an international distribution network**, LEADER is present worldwide, keeping us as close as possible to our customers.

An organisation at your service

For optimal and long-term use of the equipment you purchase, LEADER can propose suitable training **on the handling, on the use and maintenance of the equipment**. Training can be done at our site or at your own site.



CONTENTS

USAR PROTECTION AND RESPONSE EQUIPMENT

LEADER's innovative equipment exceeds the technical limits hitherto established by using new technologies to improve the field effectiveness of USAR rescue teams so that more people buried under rubble can be saved.



VICTIM SEARCH

P10

LIFE DETECTORS

FOR DETECTING VIBRATIONS OR MOVEMENTS FROM BURIED CASUALTIES AND FOR LOCATING VICTIMS.

SEARCH CAMERAS

FOR VISUALLY LOCATING AND COMMUNICATING WITH VICTIMS IN CONFINED SPACES.

2 IN 1 CAMERA/DETECTOR

ONE APPARATUS SUFFICIENT FOR VISUALLY LOCATING AND DETECTING THE POSITION OF VICTIMS.



SECURING AN AREA

P26

SURROUNDING STRUCTURE STABILITY MONITOR

FOR ALERTING RESCUERS TO A RISK OF COLLAPSE.

AC CURRENT DETECTOR

FOR WARNING OF THE PRESENCE OF AC CURRENT IN AN INTERVENTION AREA.



PERSONAL PROTECTION

P32

MULTI-RISK RESCUER HELMETS

FOR PROTECTING RESCUERS IN HAZARDOUS SITUATIONS.



TECHNICAL DATA

P36



USAR EQUIPMENT DESIGNED WITH AND FOR RESCUE SPECIALISTS

Dedicated to **USAR (Urban Search and Rescue) work**, the purpose of these innovative devices is to **effectively help rescue teams save victims** from natural disasters or major accidents such as collapse of structures, landslides, explosions, fires, etc.

Every rescue situation is different and demands **equipment** both to **help victims** and secure a rescue area or to **protect individual rescuers**.

SEISMIC SENSOR

DETECTING VIBRATIONS FROM BURIED VICTIMS

LEADER Search equipment utilizes wireless seismic technology to allow rapid deployment of up to 3 sensors for ease of use in rubble (no cable to get in the way). Wired sensors can also be connected in order to supplement the action of wireless sensors in certain conditions.

Seismic sensors are used to detect the slightest vibration and locate victims by triangulation. By systematically moving the sensors across a virtual grid representing the disaster zone, and always leaving in position the sensor that picked up the strongest signal, the victim's location is identified when all the sensors receive a signal of equal strength.

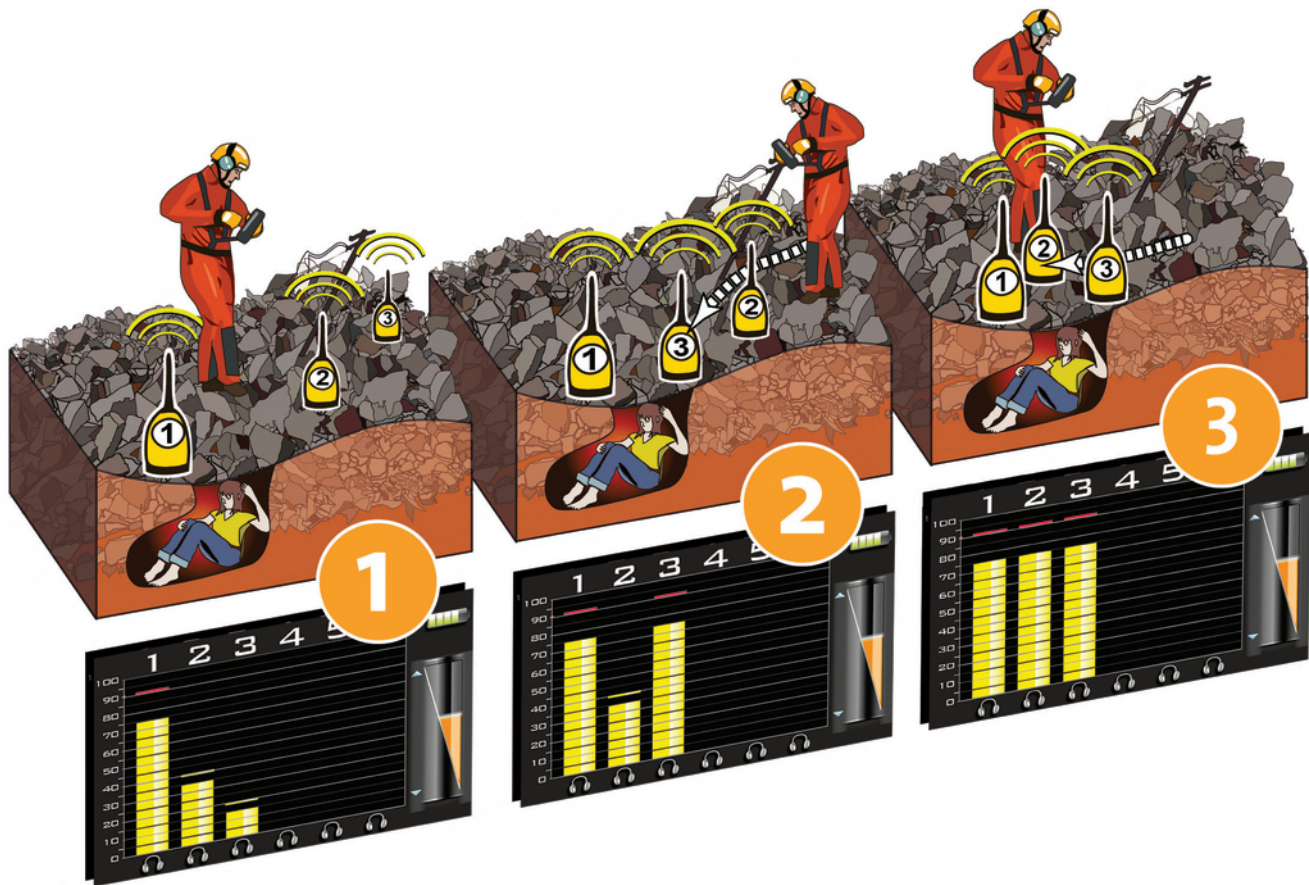

UWB SENSOR

DETECTS MOVEMENTS FROM BURIED VICTIMS

Its high sensitivity allows it to detect either irregular movements such as the movement of a finger or regular movements such as the chest movements of a victim who is breathing even if unconscious.

LEADER Scan uses wireless UWB (Ultra Wide Band) technology to allow workers to move more easily even though a wired connection is possible. An operator moves the sensor across the surface of the rubble. The aim is to map the disaster area by identifying the locations of buried victims, while a second operator monitors progress on the control box.

UWB technology detects movements in the vertical search axis of the sensor. The shape of the signal can be simply represented by a cone which accurately detects the movements of a person, or movements characteristic of breathing.



SEARCH CAMERAS

VISUAL LOCATION AND COMMUNICATION WITH A VICTIM

LEADER Cam search cameras are normally used in their extensible telescopic pole version. They allow operators to inspect inaccessible high areas or confined spaces that are difficult to access.

Reel versions with cable are also available for inspecting **cavities, crevices** and **wells** to great depths.



STABILITY MONITOR

MONITORS UNSTABLE STRUCTURES FOR MOVEMENT

The laser is pointed at a potentially hazardous structure and continuously monitors it for the slightest movement. The LEADER Sentry can secure one or two areas simultaneously. If the movement of the structure exceeds the threshold set by the operator, a powerful alarm is triggered to alert operators to an imminent danger of collapse, thus allowing evacuation of people working in the danger zone.

The apparatus can be used to monitor the movements of any object or mass likely to put people in danger, such as beam, all walls made unsafe by fire, mudflows, avalanches, vehicles in unstable situations, etc.

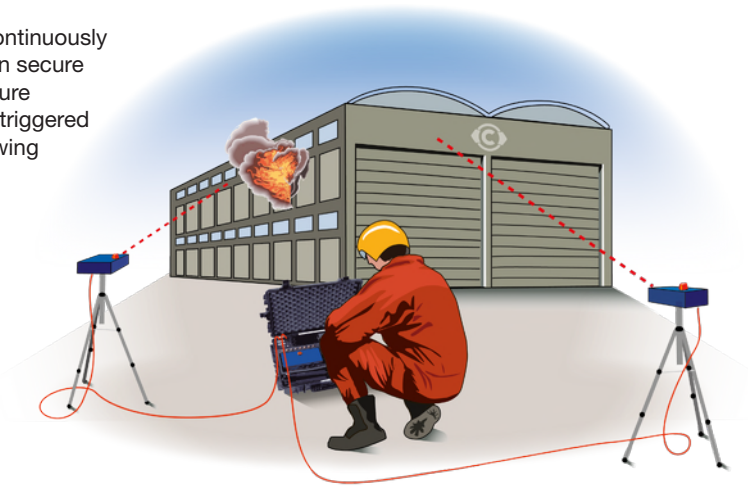

CURRENT DETECTOR

DETECTING AC ELECTRIC CURRENT IN A RESPONSE AREA

LEADER Volt alerts operators of the presence of alternating current without even having contact with the power source.

Can be used in many ways:

- For urban search and rescue following natural disasters to detect unprotected electricity sources,
- In a fire before using water and afterwards during clearance inspections,
- Or before entering a structure containing machinery that could be started up accidentally.



MULTI-RISK HELMETS

RESCUER PROTECTION

The 11 approvals gained for the LEADER Sar multi-risk helmet and its numerous accessories prove it is a true multi-purpose item with a very wide range of uses, including:

- Search & Rescue / Confined Spaces / NRBC Environments
- Marine / White water / Rescue at sea / Inflatable boats / Hovercraft
- Work at height
- Forest firefighting
- Ambulance / Medical emergencies / Road accident assistance
- Quads / Snowmobiles / Horse Riding







Wireless and / or wired life detectors

LEADER has developed life detectors using two technologies to detect buried victims :



A SEISMIC DETECTOR LEADER Search

in which the technology detects the slightest **vibration produced** by the victim by using the collapsed structure as a sort of giant microphone.

With **3 wireless sensors** for use at up to approximately 100 ft in the field and **a range of 330 ft** in open field, it also offers exceptionally good audio quality and good sound transmission for effective detection.

Designed to be rapidly deployed and easily used (no cable).

Three wired sensors can also be connected in addition to the wireless sensors.



A UWB SENSOR LEADER Scan

uses highly sensitive stabilised Ultra-Wide Band technology for detecting either **irregular movements** such as the **movement of a finger**, or **regular movements** such as the **chest movements** of a victim who is breathing even if unconscious.

It sends a signal to pick up movements in the vertical search axis of the sensor. The shape of the signal can be simply represented as a cone that **detects movements at a depth of few meters through more than 7.8 inch thick concrete wall and allows a 100 ft search in free space.**



LEADER Search

Wireless equipment: Unique worldwide!
Detection technology: Seismic

WIRELESS AND / OR WIRED SEISMIC SENSOR

+ KEY POINTS

- ▶ WIRELESS technology for fast set up and ease of movement: no more cables getting caught in the debris!
- ▶ 1 to 6 connectable seismic sensors
- ▶ Up to 3 wireless sensors, each with a range of 330 ft
- ▶ Up to 3 wired sensors, each with 26 ft of cable
- ▶ Compact and lightweight
- ▶ Ergonomic control box
- ▶ Intuitive navigation interface and menu

INCLUDED ACCESSORIES :



THE ADVANTAGES THAT MAKE THE DIFFERENCE

AN ERGONOMIC CONTROL BOX :

- ▶ Lightweight
- ▶ Compact
- ▶ Extra-wide color screen
- ▶ High brightness screen for viewing in full daylight
- ▶ Menu and intuitive navigation.
- ▶ Run time: 5 hours
- ▶ Easily replaceable lightweight compact rechargeable battery.
- ▶ Battery compatible with LEADER Hasty, LEADER Cam and LEADER Scan control boxes.
- ▶ Backup pack for 10 AAA batteries (not supplied). Makes the device functional even if the battery cannot be charged during rescue operation.

A MULTIFUNCTION DEVICE :



	FUNCTION*	IN SEISMIC SEARCH MODE
	Audio headphones volume adjustment*	Yes
	Microphone volume adjustment*	Yes
	Push to Talk*	Yes
	Screen brightness adjustment*	Yes
	Left- and right-handed use*	Yes
	Noise reduction filter adjustment* (low and high)	Yes
	Listen to each seismic sensor individually*	Yes
	Mono or Stereo listening mode* (selected sensors heard in one or both ears)	Yes
	Display trackers* to identify the strongest movement peak	Yes
	Wireless sensors' charge indicated	Yes
	Battery charge indication	Yes

*Usable simultaneously



HIGH SENSITIVITY LISTENING MODE :

WIRED AND /OR WIRELESS SEISMIC SENSORS :

- ▶ 1 to 6 seismic sensors can be connected to detect sounds from victims such as scratching, knocking, cries, etc.
 - Up to 3 wireless sensors with a range of about 100 ft in the field (no cable management because equipment is wireless)
 - Range in excess of 330 ft in open field
 - Sensor battery life: approx. 8 hrs
 - Up to 3 wired sensors, each with 26 ft cable
- ▶ Adjustable noise reduction filters to eliminate unwanted low/high noises from pneumatic drills, vehicles, the wind, electric power cables, etc.
- ▶ Mono or Stereo mode for listening to the selected sensors in one or both ears

WATERPROOF COMMUNICATION PROBE :

- ▶ Included in the complete version (3 wired + 3 wireless sensors) (optional in other versions).
- ▶ Waterproof to IP67
- ▶ With 26 ft cable
- ▶ Push to Talk function using the probe's microphone and speaker to communicate with buried victims

HIGH-PERFORMANCE NOISE-REDUCING AUDIO HEADPHONES :

- ▶ Noise-reducing design to provide great listening quality without disruptions.
- ▶ Microphone with integrated noise reducer for clear communication with victims
- ▶ 1 or 2 sets of headphones can be connected simultaneously for :
 - either listening to the sensors in seismic listening mode
 - or communicating with victims through the communication probe.

TECHNICAL DATA
PAGES 38 & 39



LEADER Scan

Detects the slightest respiratory movement of a conscious or unconscious buried victim under rubble!
Detection technology : UWB (Ultra Wide Band)

ULTRA-SENSITIVE UWB MOVEMENT SENSOR

+ KEY POINTS

- ▶ Compact and lightweight
- ▶ Detects movement from up to 100 ft away in open field
- ▶ Detects breathing from up to 33 ft away
- ▶ Real-time movement detection
- ▶ Wireless or wired connection
- ▶ Intuitive navigation interface
- ▶ Ability to save data during search
- ▶ Battery indicator visible outside of sensor
- ▶ Easily interchangeable battery

INCLUDED ACCESSORIES :



Sunshade
 Ideal for search in bright sunlight



Handstrap
 Provides a practical and ergonomic grip.



Shoulder strap
 For convenient hands-free transport



Responder's backpack
 To easily carry the sensor and control box on a rescue mission



Transport case
 Rugged, waterproof and shockproof

THE ADVANTAGES THAT MAKE THE DIFFERENCE

AN ERGONOMIC CONTROL BOX :

- ▶ Compact and lightweight
- ▶ Extra-wide color screen
- ▶ High brightness screen for viewing in full daylight
- ▶ Menu and intuitive navigation
- ▶ Run time: 5 hours with one battery
- ▶ Quickly replaceable lightweight compact rechargeable battery.
- ▶ Battery compatible with LEADER Search, LEADER Cam and LEADER Hasty control boxes.
- ▶ Back up pack for 10 AAA batteries (not supplied). Makes the device functional even if the battery cannot be charged during rescue operation.

HIGH-SENSITIVITY UWB SENSOR :

- ▶ High-sensitivity sensor using **UWB (Ultra-Wide Band) technology**
- ▶ Lightweight and compact
- ▶ Placed in a small waterproof and shockproof transport case
- ▶ Search distance : Up to 100 ft in open field
- ▶ Accuracy : approx. 3 ft
- ▶ Real-time movement detection
- ▶ 2 search modes : Manual and Automatic
- ▶ 2 batteries (each lasting 5 hours) supplied
- ▶ 2 types of connection to the control box :
 - Wi-Fi with 100 ft range (no cable management problems)
 - Waterproof wired USB (16.4 ft of cable) : Alternative in case of nearby interference preventing use of Wi-Fi

A MULTIFUNCTION DEVICE :

The control box screen indicates the depth at which the victim is located and gives visual indications on his or her movements :

- ▶ Displays large or small movements (respiratory movements or movements of a finger, for example)
- ▶ Displays frequency of movement (suggesting whether human life or not)



FUNCTION	IN UWB SEARCH MODE
GENERAL FUNCTIONS	
Screen brightness adjustment	Yes
Left- and right-handed use	Yes
Indication of charge of control box battery	Yes
Indication of connection to the control box (USB or Wi-Fi)	Yes
Indication of status of connection of control box to sensor (starting, ready to be connected, connected, not connected, error)	Yes
Data recorded (useful for examining search history, re-examining data or during training)	Yes
2 SEARCH MODES :	
AUTOMATIC search mode for rapid deployment. The apparatus automatically analyses several predefined areas and could detect up to 7 alive persons. If distance set up from 0 to 30m, it will search for 1 person (biggest movement) each 4 meters: 0-4, 4-8...24-28, 28-30.	Yes
MANUAL search mode defined by user with selection of search area (Choice of minimum and maximum depth of search area)	Yes
FUNCTIONS AVAILABLE IN SEARCH MODE	
Set minimum search depth (start)	Yes
Set maximum search depth (end)	Yes
Large or small movement indicator	Yes
OSCILLOGRAM FUNCTION	
An red arrow is placed at the depth where movement is detected. This enables the operator to : <ul style="list-style-type: none"> ▶ Confirm the presence of movements in the selected search area. 1 (If it detects several movements it will concentrate on the strongest movement) ▶ Display the frequency of the detected movement. 2 	Yes

TECHNICAL DATA
PAGES 40 & 41





Search cameras with communication system

LEADER Cam cameras are used during rescue operations to see and communicate with **buried victims**. The **compact and lightweight** control box mounted on an **ultra lightweight carbon-fiber telescopic pole** is specially designed for **precise visual location of victims** in confined spaces.



THE EXTENSIBLE TELESCOPIC POLE

allows the operator to inspect **inaccessible** high areas or confined spaces that are difficult to access. The version connected to a reel allows inspection of cavities, crevices, wells, etc.

SEARCH CAMERAS

also enable communication with the victim when found in order to assess what help is required.



LEADER Cam

Compact, lightweight and ergonomic

SEARCH CAMERA WITH BUILT-IN COMMUNICATION SYSTEM

+ KEY POINTS

- ▶ Position of camera shown on screen
- ▶ Compact and lightweight
- ▶ Ergonomic control box
- ▶ Intuitive navigation interface and menu
- ▶ Extra-wide color screen
- ▶ Ultra lightweight telescopic pole

INCLUDED ACCESSORIES :



Sunshade
Ideal for search in bright sunlight

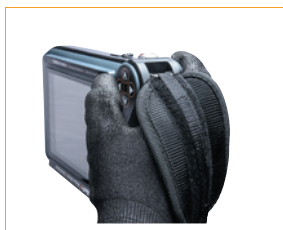

Handstrap
Provides a practical and ergonomic grip. Shoulder strap also supplied.



Transport case
Rugged, waterproof and shockproof

OPTIONAL ACCESSORY :



Cameras on reel
With 295 ft or 590 ft of cable.
Waterproof camera (up to 595 ft) or articulated, water-resistant camera with built-in communication system

THE ADVANTAGES THAT MAKE THE DIFFERENCE

AN ERGONOMIC CONTROL BOX :

- ▶ Lightweight and compact
- ▶ Extra-wide color screen
- ▶ High brightness screen for viewing in full daylight
- ▶ Menu and intuitive navigation
- ▶ Run time: 2.5 hours
- ▶ Easily replaceable lightweight compact rechargeable battery.
- ▶ Battery compatible with LEADER Search, LEADER Hasty and LEADER Scan control boxes.
- ▶ Backup pack for 10 AAA batteries (not supplied). Makes the device functional even if the battery cannot be charged during rescue operation.

A MULTIFUNCTION DEVICE :



FUNCTIONS		IN SEARCH CAMERA MODE
	Digital zoom x 2*	Yes
	Headphone(s) volume adjustment*	Yes
	Microphone volume adjustment*	Yes
	Push to Talk*	Yes
	Screen brightness adjustment*	Yes
	Left- and right-handed use*	Yes
	Image rotation* up (0°), down (180°)	Yes
	Display of camera head position*	Yes
	Display of illumination level of LEDs located on camera head*	Yes
	Battery charge indication	Yes
	Picture capture*	Yes
	Video recording* with sound	Yes
	Photo and video gallery to display recordings	Yes
	Audio recording (recording of sounds from the communication pole: communication between victim and rescuer)	Yes

*Usable simultaneously



SEARCH CAMERA MODE :

ROBUST AND WATERPROOF CAMERA HEAD :

- ▶ 170° movement of camera head and 260° total field of view
- ▶ Camera protected by scratch-resistant sapphire lens
- ▶ Flexible camera joint head to absorb shocks
- ▶ Water-resistant to 6.5 ft when camera fitted with plug
- ▶ Adjustable LED lighting with 8 intensity levels



ULTRA LIGHTWEIGHT TELESCOPIC POLE :

- ▶ Telescopic from 3.6 ft to 7.9 ft – Up to 13.1 ft available
- ▶ Ultra lightweight carbon-fiber construction
- ▶ "Articulated arm" supplied for mounting the control box on the pole



HIGH-PERFORMANCE NOISE-REDUCING AUDIO HEADPHONES :

- ▶ Noise-reducing design to provide great listening quality without disruptions.
- ▶ Microphone with integrated noise reducer for clear communication with victims
- ▶ 1 or 2 sets of headphones can be connected simultaneously

TECHNICAL DATA
PAGES 42 & 43





2-in-1 Camera/Detector

LEADER Hasty, the **WORLD'S only** multi-functional HASTY tool*, combining several several modes :



A "SEARCH CAMERA" MODE

via a camera integrated into an ultra lightweight telescopic pole for visually and precisely locating victims,

A "SEISMIC DETECTION" MODE

using 3 wireless sensors for detecting signs of life.

The combination of these modes allows the operator to **detect, locate** and **communicate** using a single tool, making deployment times shorter and increasing the survival chances of victims.

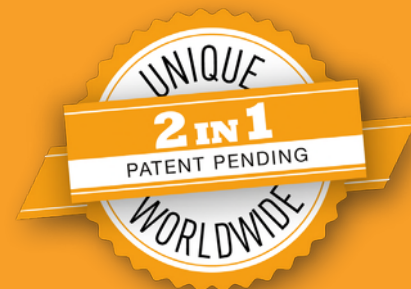



LEADER Hasty

The only search device that combines victim detection with a search camera!
Detection technology : Seismic

WIRELESS SEISMIC DETECTOR & SEARCH CAMERA

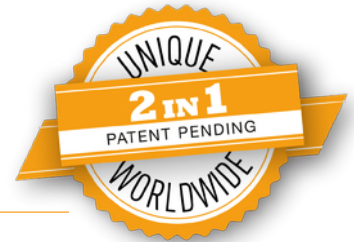

KEY POINTS

- ▶ 2-in-1 search device
- ▶ Fast deployment
- ▶ Compact and lightweight
- ▶ Ergonomic control box
- ▶ Intuitive navigation interface and menu
- ▶ Extra-wide color screen
- ▶ Ultra lightweight telescopic pole
- ▶ Up to 3 wireless seismic sensors, each with a range of 330 ft
- ▶ Position of camera shown on screen

INCLUDED ACCESSORIES :



THE ADVANTAGES THAT MAKE THE DIFFERENCE

AN ERGONOMIC CONTROL BOX :

- ▶ Compact and lightweight
- ▶ Extra-wide color screen
- ▶ High brightness screen for viewing in full daylight
- ▶ Intuitive navigation interface and menu
- ▶ Run time: 2.5 hours
- ▶ Easily replaceable lightweight compact rechargeable battery.
- ▶ Battery compatible with LEADER Search, LEADER Cam and LEADER Scan control boxes.
- ▶ Backup pack for 10 AAA batteries (not supplied). Makes the device functional even if the battery cannot be charged during rescue operation.

A MULTIFUNCTION DEVICE :

FUNCTIONS	IN SEARCH CAMERA MODE	IN SEISMIC SEARCH MODE
Digital zoom x 2*	Yes	
Headphone(s) volume adjustment*	Yes	Yes
Microphone volume adjustment*	Yes	Yes
Push to Talk*	Yes	
Screen brightness adjustment*	Yes	Yes
Left- and right-handed operation*	Yes	Yes
Image rotation* up (0°), down (180°)	Yes	Yes
Display of camera head position*	Yes	
Display of illumination level of LEDs positioned on camera head*	Yes	
Noise reduction filter adjustment (low and high)		Yes
Mono or Stereo listening mode (selected sensors heard in one or both ears)		Yes
Listen to each seismic sensor individually		Yes
Display trackers to identify the strongest movement peak		Yes
Wireless sensors' charge indicated		Yes
Battery charge indication	Yes	Yes
Picture capture*	Yes	
Video recording* with sound	Yes	
Photo and video gallery to display recordings	Yes	
Audio recording (recording of sounds from the communication pole: communication between victim and rescuer)	Yes	

*Usable simultaneously

SEARCH CAMERA MODE :

ROBUST WATERPROOF CAMERA HEAD :

- ▶ 170° movement of camera unit and 260° total field of view
- ▶ Camera protected by scratch-resistant sapphire lens
- ▶ Flexible articulation of camera unit to absorb shocks
- ▶ Water-resistant to 6.5 ft when camera fitted with plug
- ▶ Adjustable LED lighting with 8 intensity levels



ULTRA LIGHTWEIGHT TELESCOPIC POLE :

- ▶ Telescopic from 3.6 to 7.9 ft – Up to 13.1 ft available
- ▶ Ultra lightweight carbon-fiber construction
- ▶ "Articulated arm" supplied for mounting the control box on the pole



HIGH SENSITIVITY LISTENING MODE :

1, 2 OR 3 WIRELESS SEISMIC SENSORS CAN BE CONNECTED TO DETECT SOUNDS FROM VICTIM

- ▶ Range of about 100 ft in the field (no cable management because equipment is wireless)
- ▶ Range in excess of 330 ft in open field
- ▶ Sensor battery life: approx. 8 hrs

ADJUSTABLE NOISE REDUCTION FILTERS TO ELIMINATE UNWANTED LOW/HIGH NOISES FROM PNEUMATIC DRILLS, VEHICLES, THE WIND, ELECTRIC POWER CABLES, ETC.

MONO OR STEREO MODE FOR LISTENING TO THE SELECTED SENSORS IN ONE OR BOTH EARS

HIGH-PERFORMANCE NOISE-REDUCING HEADPHONES :

- ▶ Noise-reducing design to provide great listening quality without disruptions.
- ▶ Microphone with integrated noise reducer for clear communication with victims
- ▶ 1 or 2 sets of headphones can be connected simultaneously

TECHNICAL DATA
PAGES 44 & 45

OPTIONAL ACCESSORIES FOR TECHNICAL SEARCH EQUIPMENT

FOR LEADER CAM / LEADER SEARCH /
LEADER HASTY / LEADER SCAN CONTROL BOXES

BATTERY ALONE (each)

Ref	D11.04.341
Type	Lithium ion. 37 Wh
Weight	0.66 lbs



CHARGER + TRANSFORMER FOR CONTROL BOX

Charger dimensions	H 4.13 x D 1.77 x L 1.38 inch
Charger weight	0.44 lbs
Charger input voltage	100 - 240 VAC / 50-60 Hz
International connection adaptors	UK, EU, AUS, USA



SPARE BATTERY PACK

Ref	200 61 55
Weight with 10 batteries (not supplied)	0.66 lbs



NOISE-REDUCING HEADPHONES

Ref 1 pair headphones only	200 63 82
----------------------------	-----------

OPTIONAL 2ND SET NOISE-REDUCING HEADPHONES

1 pair of headphones supplied with Y connector for connecting 2 pairs of headphones to control box simultaneously	D11.04.340
---	------------



SUNSHADE

Ref	For Scan, Hasty and Cam: D11.04.339 For Search : D11.04.338
Material	Thermoformed foam with elastic straps for attaching to control box



NECK STRAP

Ref	200 63 03
Material	Braided fabric supplied with fixing clasps
Length	6 ft



HAND STRAP

Ref	200 61 97
Material	Braided fabric
Adjustment system	Velcro



ACCESSORIES SPECIFICALLY FOR SEISMIC SENSOR

SENSOR (each)	
Wireless sensor (with 1 spike and 1 magnet)	D11.04.335
Wired sensor (with 1 spike and 1 magnet)	D11.04.336



SPIKES (each)	
Ref	200 31 13
Function	Allows sensor to be used on soft ground
Material	Steel



MAGNETS (each)	
Ref	200 35 14
Function	Allows sensor to be used on metal debris
Material	Steel



COMMUNICATION PROBE	
Ref	D11.04.337
Microphone/loudspeaker	Yes
Material	stainless steel
Diameter	1.5 inch
Ingress protection	IP67
Response frequency	300 Hz to 3500 Hz
Cable length	26.2 ft
Cable type	Orange anti-abrasion cable



ACCESSORIES SPECIFICALLY FOR SEARCH CAMERA

DISCONNECTABLE ARTICULATED ARM	
Ref	200 66 21
Function	Pole/control box mounting system
Material	Articulated rigid metal spring
Weight	0.55 lbs



CAMERA ON REEL (each)	
Disconnectable articulated camera with built-in communication system with 295 ft of cable on reel	D11.04.346



WATER-RESISTANT PLUGS	
Ref	200 38 45
Function	Makes camera unit watertight up to 6.5 ft deep
Material	Plastic + rubber seal



WATER-RESISTANT CAMERA ON REEL (each)	
Water-resistant camera (non-articulating) to 295 ft depth with 295 ft of cable on reel	D11.04.347
Reel of additional 295 ft of cable	D11.04.348



EXTENSIONS	
82 ft cable	D11.04.356
295 ft cable on reel	D11.04.348
Connectors	Metal
Cable type	Orange anti-abrasion cable







Stability monitor for monitoring at-risk structures

LEADER Sentry is a movement detector that uses a laser to continuously monitor and detect the slightest movement of an unstable building or potentially unstable structure.



If the structure moves more than the threshold amount set by the operator, a **powerful alarm** is triggered to warn of the risk of **debris falling** from buildings damaged by **earthquake, bomb, gas explosion, fire or any other disaster**.

Flashing red light
Visual indication that unit is active



Protective case
Portable, lightweight and waterproof

Telescopic Sight
To pinpoint the laser on the targeted area



Rigid tripod



Monitor screen:
- Intuitive selection of menus
- Displays distance to target
- Illustrates realtime movement on screen
- Displays measurements in either Imperial or Metric (inches or mm)
- OLED screen for excellent clarity

FOR FIREFIGHTING RESPONSE



FOR USAR RESPONSE



LEADER Sentry

Monitors movements of unstable structures to alert firefighters or USAR teams to an imminent risk of collapse

MOVEMENT SENSOR FOR MONITORING STABILITY

+ KEY POINTS

- ▶ Easy to transport
- ▶ 2 laser beams can operate simultaneously
- ▶ Displays movement status on the screen in real time
- ▶ Audio and visual alarm
- ▶ Units: imperial (inches) and metric (mm)
- ▶ Rain-resistant
- ▶ OLED screen: excellent brightness even in sunlight

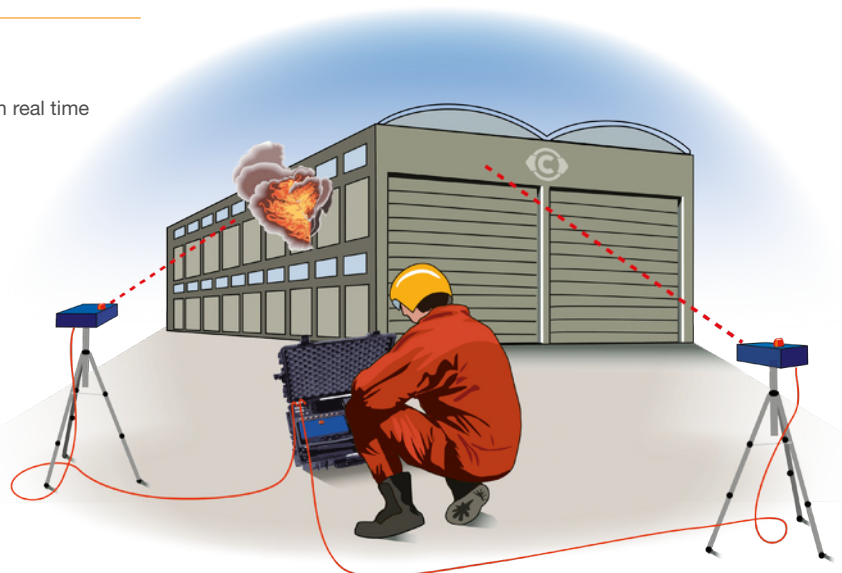

THE ADVANTAGES THAT MAKE THE DIFFERENCE

- ▶ Detects a 0.2 inch movement at a distance of 100 ft.
- ▶ A telescopic sight allows the operator to point the laser accurately at the targeted unstable structure.
- ▶ Multiple maximum movement thresholds (from 0.2 to 3.94 inch) can be selected. When a movement is sensed that exceeds the selected threshold, the sound alarm is triggered (98 dB).
- ▶ Continuously monitors detected movements and displays changes on its screen for real-time awareness.
- ▶ 2 lasers can be connected to the device to simultaneously monitor 2 sides of an unstable building for the safety of rescue teams working around or inside the structure.
- ▶ Various modes available for distinguishing between alarms, faults, etc.
- ▶ Filters out brief interruptions of beam (birds flying through beam, people briefly crossing beam etc.)

CHARACTERISTICS

Model	Dim. L x H x D	Weight	Continuous operation power supply	Backup power run time**	T°F of use and storage
LEADER Sentry B1 - Ref D11.06.010 Shockproof and waterproof case (when closed) containing console control monitor 1 x class 2* laser with 13.1ft of anti-scurff high-viz orange cable 1 x robust tripod, height-adjustable to avoid interference with site activity (5.9 ft max) with 1 integral hook for attaching ballast at its centre + 1 ball joint for mounting the laser on the tripod. 8 x AA alkaline batteries + 1 x 110/220V 50/60 Hz mains power pack with adaptors + 1 x 12V cable with vehicle AC adaptor.	25.6 x 20.1 x 9.53 inch	approx. 34.2 lbs	12V vehicle supply or 110/220V 50/60 Hz mains.	15,5 hrs with 8 x AA lithium batteries (not supplied) 7 hrs with 8 x AA alkaline supplied batteries	T°F of use : -13°F to +122°F T°F of storage : -40°F to +158°F
LEADER Sentry B2 - Ref D11.06.011 Shockproof and waterproof case (when closed) containing console control monitor 1 x class 2* laser with 13.1 ft of anti-scurff high-viz orange cable 1 x class 2* laser with 65 ft of anti-scurff high-viz orange cable 2 x robust tripods, height-adjustable to avoid interference with site activity (5.9 ft max) with 1 integral hook for attaching ballast at its centre + 2 ball joints for mounting the laser on the tripod. 16 x AA alkaline batteries + 1 x 110/220V 50/60 Hz mains power pack with adaptors + 1 x 12V cable with vehicle AC adaptor.	26.4 x 20.1 x 14.65 inch	approx. 58.4 lbs		2 connected lasers: 9 hrs with 8x AA lithium batteries (not supplied) 1 connected laser: 15,5 hrs with 8x AA lithium batteries (not supplied) 2 connected lasers: 3 hrs with 8x AA alkaline supplied batteries 1 connected laser: 7 hrs with 8x AA alkaline supplied batteries or 6 hrs (2 lasers) and 14 hrs (1 laser) by using the 2 nd set of batteries (thanks to the 16 alkaline supplied batteries)	

*Output power is less than 1 mW. In case of exposure, the natural reflex to blink and turn the head away is sufficient to protect from risk of injury.

**Maximum run time (Unit ON - flash and alarm OFF)

OPTIONAL ACCESSORIES

Model	Ref	Use temperature	Storage temperature
1 laser with tripod for LEADER Sentry B1	D11.06.012		
Sucker attachment Alternative to tripod for mounting laser on smooth surfaces (glass, vehicles etc.)	D11.06.014	-13°F to +122°F	-40°F to +158°F





LEADER Volt

Warns of presence of the alternating current at a distance

AC ELECTRIC CURRENT DETECTOR

KEY POINTS

- ▶ Detects alternating current
- ▶ Safe and easy to use
- ▶ High sensitivity
- ▶ 3 sensitivity modes
- ▶ Water resistant



THE ADVANTAGES THAT MAKE THE DIFFERENCE

SECURING THE AREA

Audio and visual warning of the presence of alternating current (AC) without even having contact with the power source.

3 SENSITIVITY MODES :

- ▶ **High sensitivity** : For remote inspection
- ▶ **Low sensitivity** : Helps find the source of the current
- ▶ **Focus mode** : Precisely detects the current in the axial direction of the device and reduces the influence of other nearby cables



MAIN APPLICATIONS :

- ▶ **Urban Search and Rescue** : Detects unknown sources of AC that are unprotected and dangerous.
- ▶ **Fire** : During and after fires, construction work and inspections.
- ▶ **Vehicle extractions** : Rapid check of intervention site and vehicles in order to identify any AC-related risk. Enables operator to check that electrical circuits are disconnected.
- ▶ **Rescue in Confined Spaces** : Allows operator to check that electrical power is off at the entrance of a site containing machinery or equipment that could be accidentally started up.
- ▶ **Natural disasters** : Rapid check of the extent of a power cut following an earthquake, storm, flood or snow storm. LEADER Volt enables operator to identify live wiring on roads or in spaces inside collapsed buildings or on flooded sites.
- ▶ **Trench rescue** : For locating potential sources of electrical hazards during rescue operations.

MAIN CHARACTERISTICS

- ▶ Weight: 1.26 lbs
- ▶ Dimensions: Diameter: 1.77 inch / Length: 20.51 inch
- ▶ Duration: One set of alkaline batteries (4 x AA alkaline supplied) gives one year of service (if permanently on = 300 hours)
- ▶ Can be used for frequencies from 20 to 100 Hz
- ▶ Temperatures :
 - use: from -22 to +122°F
 - storage and transport: from -40 to +158°F
- ▶ Typical detection distance :

Voltage	Frequency	Settings	Detection distance adjustment		
			High sensitivity	Low sensitivity	Focus mode
120 VAC 220 VAC	60 Hz 50 Hz	Single conductor (5.9 ft above ground)	15.1 ft	2.95 ft	5.9 inch
120 VAC 220 VAC		Conductor on wet ground	2.95 ft	5.9 inch	1 inch
7.2 kV 16 kV		Overhead distribution line (single insulator)	213 ft	69 ft	19.7 ft
46 kV	60 Hz	Overhead transmission line (several insulators)	>492 ft	>197 ft	>65 ft



CAUTION

LEADER Volt detects only AC (Alternating Current) on damaged/stripped cables. Does not detect DC (Direct Current) such as underground railway train cables, tram cables, very high voltage cables and solar panels.





Multi-risk helmet



Lightweight and comfortable, the LEADER Sar multi-risk helmet provides optimal protection in its basic configuration. It meets the requirements of responders in dangerous or hazardous situations during rescue missions.



Its great **shock-absorbing** capacity enables it to withstand **violent blows from above or from the front, sides or rear**, thus providing very effective head protection.



Its **11 type approvals** and its numerous accessories make the LEADER Sar multi-risk helmet a true **multi-function** item with a **very wide range of applications**.





LEADER Sar

This multi-risk helmet meets the requirements of responders in dangerous or hazardous situations during rescue missions.

MULTI-RISK HELMET

11 TYPE APPROVALS MAKE THIS A TRUE MULTI-FUNCTION ITEM WITH A WIDE RANGE OF APPLICATIONS :

- ▶ Search & Rescue / Confined Spaces / CBRN Environments
- ▶ Marine / Swiftwater / Water Rescue / Ribs / Hovercraft
- ▶ Working at height
- ▶ Forest firefighting
- ▶ Ambulance / Medical emergencies / Road accident assistance
- ▶ Quads / Snowmobiles / Horse Riding



KEY POINTS

- ▶ Light and comfortable
- ▶ Gives optimal protection
- ▶ Meets the requirements of responders in dangerous situations during rescue missions
- ▶ Many accessories

THE ADVANTAGES THAT MAKE THE DIFFERENCE

TYPE APPROVALS & CONFORMITIES

TYPE APPROVALS :

- ▶ EN14052 - 2005: High-performance safety helmet
- ▶ EN397: Flame resistance
- ▶ EN12492: Work at height / Mountaineering
- ▶ PAS 028 - 2002: Marine safety helmet
- ▶ FS/1: Quad bikes and ATVs
- ▶ EN1384: Protective horse-riding helmet
- ▶ EN166 - 2002: Eye protection in industrial environments
- ▶ EN352-3 - 1997: Hearing protection

MEETS THE FOLLOWING STANDARDS * :

- ▶ NFPA1951 - 2007: Protective Ensembles Technical Rescue Incidents (USAR)
- ▶ NFPA 1952:2010: Surface Water Operations Protective Clothing and Equipment 2010 Edition
- ▶ ANSI Z89.1 Type 2 Class C: American National Standard for Industrial Head Protection
- ▶ EN 16471 (in progress) : Wildland firefighting
- ▶ EN 16473 (in progress) : Technical rescue

*European third party tests confirm the LEADER Sar All Risks helmet meets or exceeds the standards listed.

CHARACTERISTICS

THICKNESS & WEIGHT :

- ▶ Shell = 0.12 - 0.24 inch
- ▶ Inner cradle and liner = 0.71 - 0.87 inch
- ▶ Helmet = 1.21 lbs

STRENGTH :

- ▶ Top part = 100 joules
- ▶ Sides/Front/Rear = 90 joules

OPTIONAL ACCESSORIES

Options are supplied not fitted to the helmet. They are additional to the standard equipment (clear visor and photoluminescent vent covers).



Full face transparent polycarbonate visor

Ref: H20.60.010

Requires visor mount **H20.60.012** and visor mount adaptor **H20.60.013** in order to be fitted.



Protective mesh visor

Ref: H20.60.011

For forestry work. Requires visor mount H20.60.012 and visor mount adaptor H20.60.013 in order to be fitted.



Side mount for attaching a torch

Ref: H20.60.027

Adaptable mount for attaching a torch (torch not supplied).



Smoked integral visor

Ref: H20.60.015

Reduces brightness of sun while maintaining optimal colour vision.



Visor mount

Ref: H20.60.012



Neck protection

Ref: H20.60.017



Full face transparent marine visor 6.9 inch

Ref: H20.60.008

Made of LEXAN polycarbonate, is designed to provide additional protection against risks on board fast boats. Meets requirements of standard EN166.



Ambered integral visor

Ref: H20.60.016

Reduces the blue light from the sun's spectrum. The image is sharper, though some slight distortion of colours may occur.



Helmet mount adaptor for visor mount

Ref: H20.60.013

If the helmet is fitted with ear defenders, this adaptor is not required because the visor mount can be secured directly to the ear defenders.



Ear defenders

Ref: H20.60.018

26dB attenuation. The pair are supplied with an adaptor piece to accept the visor mount.



Semi-face transparent marine visor 5.1 inch

Ref: H20.60.009

Made of LEXAN polycarbonate, is designed to provide additional protection against risks on board fast boats. Meets requirements of standard EN166.



Transparent integral visor

Ref: H20.60.031



Inside foam padding

Ref: H20.60.053



Interchangeable sweat band

Ref: H20.60.025



Protective goggles

Ref: H20.60.026

AIR VENT COVERS (PER PAIR) :

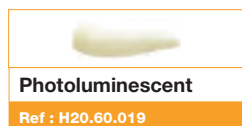

Photoluminescent

Ref: H20.60.019



Red

Ref: H20.60.020



Green

Ref: H20.60.021



Black

Ref: H20.60.022



Yellow

Ref: H20.60.023



Royal blue

Ref: H20.60.024



Technical data for
search equipment

LEADER Search
LEADER Scan
LEADER Cam
LEADER Hasty

POSSIBLE COMBINATIONS DEPENDING ON SELECTED OPTIONS

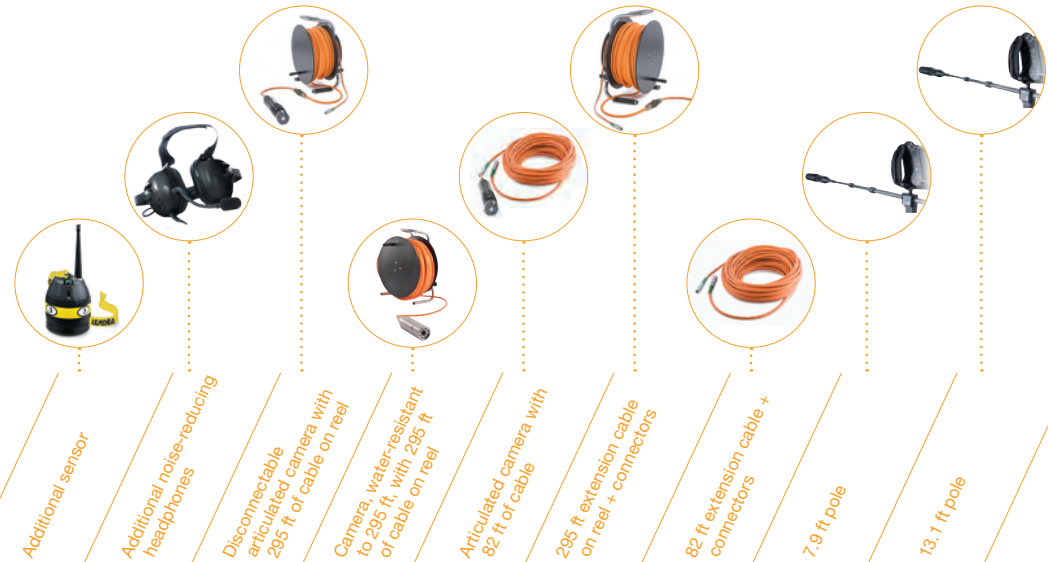

	Ref	D11.04.335	D11.04.340	D11.04.346	D11.04.347	D11.04.362	D11.04.348	D11.04.356	2006158	2006557
LEADER Cam 7.9 ft	D11.04.342	0	1	1	1	1	0 (or 1 if used in combination with a D11.04.347)	1	0	1
LEADER Cam 13.1 ft	D11.04.343	0	1	1	1	1		1	1	0
LEADER Hasty 7.9 ft + 1 sensor	D11.04.349	2	1	1	1	1		1	0	1
LEADER Hasty 13.1 ft + 1 sensor	D11.04.350	2	1	1	1	1		1	1	0
LEADER Hasty 7.9 ft + 2 sensors	D11.04.351	1	1	1	1	1		1	0	1
LEADER Hasty 13.1 ft + 2 sensors	D11.04.352	1	1	1	1	1		1	1	0
LEADER Hasty 7.9 ft + 3 sensors	D11.04.359	0	1	1	1	1		1	0	1
LEADER Hasty 13.1 ft + 3 sensors	D11.04.360	0	1	1	1	1		1	1	0
LEADER Cam R90 including 295 ft reel and disconnectable articulated camera	D11.04.344	0	1	0	1	1	1	0	1 (in place of reel but not at the end)	1 (in place of reel but not at the end)
LEADER Cam RD90 including 295 ft reel and camera waterproof up to 295 ft deep	D11.04.345	0	2	1	0	1	1 (camera waterproof only to 295 ft)	0	1 (in place of reel but not at the end)	1 (in place of reel but not at the end)



TECHNICAL DATA LEADER Search

**WIRELESS AND/OR
WIRED SEISMIC
DETECTOR**

AVAILABLE VERSIONS

Contents of case	1 control box + 2 wired sensors	1 control box + 3 wired sensors	1 control box + 2 wireless sensors	1 control box + 3 wireless sensors	1 control box + 3 wired sensors + 3 wireless sensors
Ref	D11.04.330	D11.04.331	D11.04.332	D11.04.333	D11.04.334
Control box	1	1	1	1	1
Antenna	-	-	1	1	1
Pair of noise-reducing headphones	1	1	1	1	1
Sunshade	1	1	1	1	1
Shoulder strap	1	1	1	1	1
Hand strap	1	1	1	1	1
Wired seismic sensors	2	3	-	-	3
Wireless seismic sensors	-	-	2	3	3
Communication probe	option	option	option	option	1
Spikes for sensors	2	3	2	3	6
Magnets for sensors	2	3	2	3	6
Battery	1	1	1	1	1
Charger	1	1	1	1	1
International connection adaptor kits	1	1	1	1	1
Spare battery pack (without batteries)	1	1	1	1	1
Orange transport case	1	1	1	1	1
User manual	1	1	1	1	1

CONTROL BOX CHARACTERISTICS

CONTROL BOX	
Dimensions	L 9.5 x W 6 x H 2 inch
Control box weight without battery	2.1 lbs
Control box weight with battery	2.7 lbs
Control box material	Polypropylene
Anti-shock bumper	Rubber belt around the thickness
Shock resistance	Drop test performed up to 6.5 ft
Control box water and dust resistance	IP54
Run time	5 hours
Startup time	< 1 minute
Keyboard	Phosphorescent
Connections	3 metal ports for connecting headphones, antenna, communication probe or wired sensors
Antenna for interconnection of seismic sensors	Removable and orientable for a range of up to 330 ft in unobstructed space
Connector water and dust resistance	IP68
Operating temperatures	From +14° to +140°F
Storage temperature	From -40° to +158°F

SCREEN	
Type	TFT LCD
Resolution	5" - 800 x 480 px WVGA
Brightness	93 candela / ft ²
Backlighting	LED
Colors	16-bit RGB
Protection	Transparent thermoplastic: 0.12 inch colorless scratch-resistant PMMA

SEISMIC SEARCH EQUIPMENT CHARACTERISTICS

	SEISMIC SENSORS	
	Wireless connection to control unit	Wired connection to control unit
Dimensions with antenna	Height 8.35 inch x Diameter 3.54 inch	Height 3.35 inch x Diameter 3.54 inch
Weight (with standard cell batteries)	1.85 lbs	3.1 lbs
Specificity	Up to 3 sensors with 330 ft range each in unobstructed space	Up to 3 sensors, each with 26.2 ft of anti-abrasion high-viz orange cable
Sensor/control box communication frequency	2.4 GHz	-
Water and dust resistance	IP67	
Shock resistance	Yes	
Audio response frequency	1 Hz to 3000 Hz	
Run time	Approximately 8 hrs depending on battery make	-
Individual control of each sensor from control box	Each sensor can be listened to alone or simultaneously with the second sensor.	
Noise-reducing filters adjustable from control box	Low-pass filter: Removes high sounds. Adjustable from 600 to 3000 Hz High-pass filter: Removes deep sounds. Adjustable from 20 to 300 Hz	
Mono or Stereo listening mode	For listening to the selected sensors in both ears, right ear only or left ear only	
On-screen display trackers	Yellow trackers above each bar graph for clear reading of peaks. Red tracker identifies the highest seismic peak, staying on screen for an additional brief period.	

COMMUNICATION PROBE	
Option, except in the 3 wired sensors + 3 wireless sensors version Ref D11.04.334	
Ref	D11.04.337
Material	stainless steel
Diameter	1.5 inch
Ingress protection	IP67
Microphone/loudspeaker	Yes
Response frequency	300 Hz to 3500 Hz
Cable length	26.2 ft
Cable type	Orange anti-abrasion cable

NOISE-REDUCING HEADPHONES	
Weight	Approx. 0.95 lbs
Mono or Stereo	Stereo
Built-in microphone	Yes, to communicate with victims in search camera mode
NRN (Noise Reduction Rating) hearing protection	23 dB
Number of simultaneously connectable pairs of headphones	2 pairs simultaneously connectable, one being optional (supplied with a Y connector for connecting 2 pairs of headphones to the same control box)

POWER SUPPLY

CHARGER + TRANSFORMER	
Charger dimensions	H 0.4 x W 0.2 x L 0.15 inch
Charger weight	0.44 lbs
Charger input voltage	100 - 240 VAC / 50-60 Hz
International connection adaptors	Yes: UK, EU, AUS, USA

CONTROL BOX BATTERY	
Dimensions	L 2.5 x W 5.1 x H 1.2 inch
Weight	0.62 lbs
Type	4 Lithium Ion Polymer cells. 37 Wh
Capacity	2500 mA/hour
Run time	5 hours
Charging time	3 hours 30 min
Recharging cycles	500
Charging temperature	+32° to +113°F
Water and dust resistance	IP54
Battery compatible and interchangeable	Yes with LEADER Hasty, LEADER Cam and LEADER Scan
Charge level indication	Continuously displayed on control box screen

SPARE BATTERY PACK	
Dimensions	L 2.5 x W 5.1 x H 1.2 inch
Weight with 10 batteries (not supplied)	0.66 lbs
Type and number of batteries required	10 x AAA-LR03 lithium batteries
Run time	Approx. 1 h 30 min depending on battery make

WIRELESS SENSORS POWER SUPPLY	
Type and number of batteries required	3 x AAA - LR03 alkaline batteries
Run time	Approx. 8 hrs depending of the standard cell batteries brand

TRANSPORT CASE

TRANSPORT CASE	
Material	Rigid impact-resistant polypropylene shell
Suitable for air transport	Integral pressure equalising valve
Dimensions	L 25.6 x W 20.1 x H 9.5 inch
Empty weight	15.4 lbs
Loaded case weight (maximum configuration)	56.4 lbs
Water and dust resistance	IP67

RESPONDER'S BACKPACK	
Material	Polyester 1200
Dimensions	L 22.4 x W 18.5 x D 7.9 inch
Empty weight	5.5 lbs
Color	Red



TECHNICAL DATA LEADER Scan

UWB MOVEMENT DETECTOR

COMPOSITION OF EACH PRODUCT

CONTENTS OF CASE	1 control box + 1 UWB sensor
	Ref D11.07.023
Control box	1
Antenna for control box	1
Battery for control box	1
Charger for control box	1
Spare battery pack (without batteries) for control box	1
Sunshade	1
Shoulder strap	1
Hand strap	1
UWB sensors	1
Photo/video SD memory card	1
16.4ft USB cable for connecting control box to sensor	1
Battery for UWB sensor	2
Charger for UWB sensor	1
International connection adaptor kits	1
Transport backpack	1
Waterproof and shockproof transport case	1
User manual	1

CONTROL BOX CHARACTERISTICS

CONTROL BOX	
Dimensions	L 9.5 x W 6 x H 2 inch
Control box weight without battery	2.43 lbs
Control box weight with battery	3.04 lbs
Control box material	Polypropylene
Anti-shock bumper	Rubber belt around the thickness
Shock resistance	Drop test performed up to 6.5 ft
Water and dust resistance	IP54
Run time	5 hours
Startup time	< 1 minute
Keyboard	Phosphorescent
Connections	2 metal ports for connecting UWB sensor and antenna
Operating temperatures	From +14° to +140°F
Storage temperature	From -40° to +158°F
Antenna for UWB sensor connection	Removable and articulated for a range of up to 100 ft in open field

SCREEN	
Type	TFT LCD
Resolution	7" - 800 x 480 px WVGA
Brightness	93 candela / ft ²
Backlighting	LED
Colors	16-bit RGB
Protection	Transparent thermoplastic: 0.12 inch colorless scratch-resistant PMMA

UWB SEARCH EQUIPMENT CHARACTERISTICS

UWB SENSOR	
Material	Sensor contained in a waterproof and shockproof orange ABS case
Technology	UWB: Ultra Wide Band
Search distance	Up to 100 ft in open air
Accuracy	Approx. 3.28 ft
Type of connection to control unit	- Wi-Fi connection to control unit with more than 100 ft range. Eliminates cable management problems - Waterproof USB connection with 16.4 ft of cable: Alternative in case of nearby interference preventing Wi-Fi use
Dimensions with antenna	L 17 x W 9.6 x H 13.4 inch
Weight (including battery)	14.7 lbs

POWER SUPPLY

CONTROL BOX BATTERY	
Dimensions	L 2.5 x W 5.1 x H 1.2 inch
Weight	0.62 lbs
Type	4 Lithium Ion Polymer cells (Wh)
Capacity	2500 mA.h
Run time	5 hours
Charging time	3.5 hours
Recharging cycles	500
Charging temperature	+32° to +113°F
Water and dust resistance	IP54
Battery compatible and interchangeable	Yes with LEADER Search, LEADER Cam and LEADER Hasty
Charge level indication	Displayed on control box screen

CHARGER + TRANSFORMER FOR CONTROL BOX	
Charger dimensions	H 0.4 x W 0.2 x L 0.15 inch
Charger weight	0.44 lbs
Charger input voltage	100 - 240 VAC / 50-60 Hz
International connection adaptors	Yes: UK, EU, AUS, USA

SPARE BATTERY PACK FOR CONTROL BOX	
Dimensions	L 2.5 x W 5.1 x H 1.2 inch
Weight with 10 batteries (not supplied)	0.66 lbs
Type and number of batteries required	10 x AAA-LR03 lithium batteries
Run time	Approx. 2 h depending on the standard cell batteries brand

UWB SENSOR BATTERY	
Dimensions	L 3.82 x W 5.75 x H 1.51 inch
Weight	1.37 lbs
Type	Li-Ion Endura CUE - D75
Capacity	4.9A / 59W
Run time	5 hours
Charging time	4 hours
Recharging cycles	500
Charging temperature	+32 to +104°F
Charge level indication	Visible on outside of sensor

CHARGER + TRANSFORMER FOR UWB SENSOR	
Charger dimensions	H 3.3 x D 5.6 x L 1.1 inch
Charger weight	0.8 lbs
Charger input voltage	100 - 240 VAC / 50-60 Hz
International connection adaptors	Yes: UK, EU, AUS, USA

TRANSPORT CASE AND BACKPACK

TRANSPORT CASE	
Material	Rigid impact-resistant polypropylene shell
Suitable for air transport	Integral pressure equalizing valve
Dimensions	H 14.6 x W 20.1 x L 26.4 inch
Empty weight	Approx. 28.7 lbs
Loaded case weight	66 lbs
Water and dust protection	IP67
Number of wheels	2

RESPONDER'S BACKPACK	
Material	Polyester 1200
Dimensions	L 22.4 x W 18.5 x D 7.9 inch
Empty weight	5.5 lbs
Color	Red



TECHNICAL DATA LEADER Cam

SEARCH CAMERA

AVAILABLE VERSIONS

Contents of case	1 control box + 1 pole (7.9 ft)	1 control box + 1 pole (13.1 ft)	1 control box + 1 articulated camera on 295 ft reel	1 control box + 1 articulated camera on 590 ft reel	1 control box + 1 water-resistant camera on 295 ft reel
Ref	D11.04.342	D11.04.343	D11.04.344	D11.04.366	D11.04.345
Control box	1	1	1	1	1
Pair of noise-reducing headphones	1	1	1	1	0
Sunshade	1	1	1	1	1
Articulated camera on 7.9 ft telescopic pole	1	0	0	0	0
Articulated camera on 13.1 ft telescopic pole	0	1	0	0	0
Articulated camera on 295 ft reel	0	0	1	0	0
Articulated camera on 295 ft reel + 295 ft extension on a second reel	0	0	0	1	0
Non-articulated camera (water-resistant to 295 ft) on 295 ft reel	0	0	0	0	1
Removable articulated arm (pole/control box mounting)	1	1	1	1	1
Shoulder strap	1	1	1	1	1
Hand strap	1	1	1	1	1
Water-resisting plugs (camera water-resistance accessory)	3	3	3	3	0
Battery	1	1	1	1	1
Charger	1	1	1	1	1
International connection adaptor kits	1	1	1	1	1
Spare battery pack (without batteries)	1	1	1	1	1
Photo/video SD memory card	1	1	1	1	1
Waterproof transport case	1	1	1	2	1
User manual	1	1	1	1	1

CONTROL BOX CHARACTERISTICS

CONTROL BOX	
Dimensions	L 9.5 x W 6 x H 2 inch
Control box weight without battery	2.43 lbs
Control box weight with battery	3.04 lbs
Control box material	Polypropylene
Anti-shock bumper	Rubber belt around the thickness
Shock resistance	Drop test performed up to 6.5 ft
Control box water and dust resistance	IP54
Run time	2 hours 30 min
Startup time	< 1 minute
Keyboard	Phosphorescent
Connections	3 metal ports for connecting headphones and camera
Connections water and dust resistance	IP68
Memory card	Slot for micro SD card for recording photos and videos
Software updating	By specific LEADER USB stick
Operating temperatures	From +14° to +140°F
Storage temperature	From -40° to +158°F
Control unit/pole mounting system	Yes, intended position on back of control box for attaching the supplied articulated arm to connect control unit to pole

SCREEN	
Type	TFT LCD
Resolution	7" - 800 x 480 px WVGA
Brightness	93 candela / ft ²
Backlighting	LED
Colors	16-bit RGB
Protection	Transparent thermoplastic: 0.12 inch colorless scratch-resistant PMMA
Digital zoom	x2

SEARCH CAMERA CHARACTERISTICS

CAMERA HEAD	
Diameter	1.85 inch for entering standard 2.01 inch core holes
Camera articulation	170° (85° to right and 85° to left)
Field of view	260° in total
Type of articulation	Rotation by electric motor
Camera articulation control	From control box
Water resistance	Yes, to 6.5 ft when plug fitted to camera unit (waterproof mode)
Lighting type	8 LEDs with 8 levels of illumination.
Microphone/loudspeaker	Integrated into camera head for half-duplex communication with victim
Response frequency	300 Hz to 3500 Hz

CAMERA	
Type of optics	Lens
Lens	Scratch-proof sapphire
Focal length	F = 0.12 inch fixed
Opening	90°

NOISE-REDUCING HEADPHONES	
Weight	Approx. 0.95 lbs
Mono or Stereo	Stereo
Built-in microphone	Yes, to communicate with victims in search camera mode
NRN (Noise Reduction Rating) hearing protection	23 dB
Number of simultaneously connectable pairs of headphones	2 pairs simultaneously connectable, one being optional (supplied with a Y connector for connecting 2 pairs of headphones to the same control box)

POLE		
	7.9 ft version	13.1 ft version
Material	Carbon fiber	
Dimensions	Retracted: 3.6 ft Extended: 7.9 ft	Retracted: 3.6 ft Extended: 13.1 ft
Weight	3.1 lbs	4.4 lbs
Removable pistol grip	Yes	
Pole/control box mounting system	Yes, intended location at the back of the control box to fix an "articulated arm" which will allow the user to link the control box at the pole.	

POWER SUPPLY

CONTROL BOX BATTERY	
Dimensions	L 2.5 x W 5.1 x H 1.2 inch
Weight	0.62 lbs
Type	4 Lithium Ion Polymer cells. 37 Wh
Capacity	2500 mA/hour
Run time	2 hours 30 min
Charging time	3 hours 30 min
Recharging cycles	500
Charging temperature	+32° to +113°F
Water and dust resistance	IP54
Battery compatible and interchangeable	Yes with LEADER Search, LEADER Scan and LEADER Hasty
Charge level indication	Continuously displayed on control box screen

CHARGER + TRANSFORMER	
Charger dimensions	H 0.4 x W 0.2 x L 0.15 inch
Charger weight	0.44 lbs
Charger input voltage	100 - 240 VAC / 50-60 Hz
International connection adaptors	Yes: UK, EU, AUS, USA

SPARE BATTERY PACK	
Dimensions	L 2.5 x W 5.1 x H 1.2 inch
Weight with 10 batteries (not supplied)	0.66 lbs
Type and number of batteries required	10 x AAA-LR03 lithium batteries
Run time	Approx. 1 h 30 m depending on the standard cell batteries brand

TRANSPORT CASES / 4 models

	LEADER Cam	LEADER Cam with articulated camera on 295 ft reel	LEADER Cam with waterproof camera on 295 ft reel	LEADER Cam with articulated camera on 2 reels of 295 ft (590 ft total length)
Ref	D11.04.342	D11.04.344	D11.04.345	D11.04.366
Material	Rigid impact-resistant polypropylene shell			
Suitable for air transport	Integral pressure equalizing valve			
Dimensions	H 7.1 x W 16.9 x L 47.6 inch	H 20.1 x W 9.8 x L 25.2 inch		2 cases of H 20.1 x W 9.8 x L 25.2 inch
Empty weight	17.2 lbs	17.5 lbs		35 lbs (17.5 lbs x2 cases)
Loaded case weight	30.9 lbs	50.7 lbs	51.8 lbs	101.4 lbs (50.7 lbs x2 cases)
Water and dust resistance	IP67			
Number of wheels	2	On request		



TECHNICAL DATA LEADER Hasty

**WIRELESS SEISMIC
DETECTOR
& SEARCH CAMERA**

AVAILABLE VERSIONS

Contents of case	1 control box + 1 sensor + 1 pole (7.9 ft)	1 control box + 2 sensors + 1 pole (7.9 ft)	1 control box + 3 sensors + 1 pole (7.9 ft)	1 control box + 1 sensor + 1 pole (13.1 ft)	1 control box + 2 sensors + 1 pole (13.1 ft)	1 control box + 3 sensors + 1 pole (13.1 ft)
Ref	D11.04.349	D11.04.351	D11.04.359	D11.04.350	D11.04.352	D11.04.360
Control box	1	1	1	1	1	1
Antenna	1	1	1	1	1	1
Pair of noise-reducing headphones	1	1	1	1	1	1
Sunshade	1	1	1	1	1	1
Camera on 7.9 ft telescopic pole	1	1	1	-	-	-
Camera on 13.1 ft telescopic pole	-	-	-	1	1	1
Removable articulated arm (pole/control box mounting)	1	1	1	1	1	1
Shoulder strap	1	1	1	1	1	1
Hand strap	1	1	1	1	1	1
Water-resisting plugs (camera water-resistance accessory)	3	3	3	3	3	3
Wireless seismic sensors	1	2	3	1	2	3
Spikes for sensors	1	2	3	1	2	3
Magnets for sensors	1	2	3	1	2	3
Battery	1	1	1	1	1	1
Charger	1	1	1	1	1	1
International connection adaptor kits	1	1	1	1	1	1
Spare battery pack (without batteries)	1	1	1	1	1	1
Photo/video SD memory card	1	1	1	1	1	1
Waterproof transport case	1	1	1	1	1	1
User manual	1	1	1	1	1	1

CONTROL BOX CHARACTERISTICS

CONTROL BOX	
Dimensions	L 9.5 x W 6 x H 2 inch
Control box weight without battery	2.43 lbs
Control box weight with battery	3.04 lbs
Control box material	Polypropylene
Anti-shock bumper	Rubber belt around the thickness
Shock resistance	Drop test performed up to 6.5 ft
Water and dust resistance	IP54
Run time	2.5 hours
Startup time	< 1 minute
Keyboard	Phosphorescent
Connections	3 metal ports for connecting headphones, camera and antenna
Memory card	Slot for micro SD card for recording photos and videos
Software updating	By specific LEADER USB stick
Operating temperatures	From +14° to +140°F
Storage temperature	From -40° to +158°F
Antenna for interconnection of seismic sensors	Removable and articulated for a range of up to 330 ft in with seismic sensors in unobstructed space
Control unit/pole mounting system	Yes, intended position on back of control box for attaching the supplied articulated arm to connect control unit to pole

SCREEN	
Type	TFT LCD
Resolution	7" - 800 x 480 px WVGA
Brightness	93 candela / ft ²
Backlighting	LED
Colors	16-bit RGB
Protection	Transparent thermoplastic: 0.12 inch colorless scratch-resistant PMMA
Digital zoom	x2

TRANSPORT CASE

TRANSPORT CASE	
Material	Rigid impact-resistant polypropylene shell
Suitable for air transport	Integral pressure equalizing valve
Dimensions	H 7.1 x W 16.9 x L 47.6 inch
Empty weight	17.2 lbs
Loaded case weight	35.3 lbs
Water and dust resistance	IP67
Number of wheels	2

SEARCH CAMERA CHARACTERISTICS

POLE		
	7.9 ft version	13.1 ft version
Material	Carbon fiber	
Dimensions	Retracted: 3.6 ft Extended: 7.9 ft	Retracted: 3.6 ft Extended: 13.1 ft
Weight	3.1 lbs	4.4 lbs
Detachable grip	Yes	
Pole/control box mounting system	Yes, intended position on top of pole for attaching the supplied articulated arm to connect the control unit and pole together	

CAMERA	
Type of optics	Lens
Lens	Scratch-proof sapphire
Focal length	F = 0.12 inch fixed
Opening	90°

CAMERA UNIT	
Diameter	1.85 inch for entering standard 2.01 inch core holes
Camera articulation	170° (85° to right and 85° to left)
Field of view	260° in total
Type of articulation	Rotation by electric motor
Camera articulation control	From control box
Water resistance	Yes, to 6.5 ft when plug fitted to camera unit (Waterproof mode)
Lighting type	8 LEDs with 8 levels of illumination.
Microphone/loudspeaker	Integrated into camera for half-duplex communication with victim
Response frequency	300 Hz to 3500 Hz

SEISMIC SEARCH EQUIPMENT CHARACTERISTICS

WIRELESS SEISMIC SENSORS	
Type of connection to control unit	Wireless
Wireless seismic sensors	Up to 3 sensors with 330 ft range each in open field
Dimensions with antenna	Height 8.3 inch x Diameter 3.5 inch
Weight (with standard cell batteries)	1.52 lbs
Sensor/control box communication frequency	2.4 GHz
Water and dust resistance	IP67
Shock resistance	Yes
Audio response frequency	1 Hz to 3000 Hz
Individual control of each sensor from control box	Each sensor can be listened to alone or simultaneously with the second sensor.
Noise-reducing filters adjustable from control box	Low-pass filter: Removes high sounds. Adjustable from 600 to 3000 Hz High-pass filter: Removes deep sounds. Adjustable from 20 to 300 Hz
Mono or Stereo listening mode	For listening to the selected sensors in both ears, right ear only or left ear only
On-screen display trackers	Yellow trackers above each bar graph for clear reading of peaks. Red tracker identifies the highest seismic peak, staying on screen for an additional brief period.

NOISE-REDUCING HEADPHONES	
Weight	Approx. 0.95 lbs
Mono or Stereo	Stereo
Built-in microphone	Yes, to communicate with victims in search camera mode
NRR (Noise Reduction Rating) hearing protection	23 dB
Number of simultaneously connectable pairs of headphones	2 pairs simultaneously connectable, one being optional (supplied with a Y connector for connecting 2 pairs of headphones to the same control box)

POWER SUPPLY

CONTROL BOX BATTERY	
Dimensions	L 9.5 x W 6 x H 2 inch
Weight	0.62 lbs
Type	4 Lithium Ion Polymer cells. 37 Wh
Capacity	2500 mA/hour
Run time	2 hours 30 min
Charging time	3 hours 30 min
Recharging cycles	500
Charging temperature	+32° to +113°F
Water and dust resistance	IP54
Battery compatible and interchangeable	Yes with LEADER Search, LEADER Cam and LEADER Scan
Charge level indication	Displayed on control box screen

CHARGER + TRANSFORMER	
Charger dimensions	H 0.4 x W 0.2 x L 0.15 inch
Charger weight	0.44 lbs
Charger input voltage	100 - 240 VAC / 50-60 Hz
International connection adaptors	Yes: UK, EU, AUS, USA

SPARE BATTERY PACK	
Dimensions	L 2.5 x W 5.1 x H 1.2 inch
Weight with 10 batteries (not supplied)	0.66 lbs
Type and number of batteries required	10 x AAA-LR03 lithium batteries
Run time	Approx. 1 h 30 min depending on standard cell batteries brand

WIRELESS SENSORS POWER SUPPLY	
Type and number of batteries required	3 x AAA - LR03 alkaline batteries
Run time	Approx. 8 hrs depending of the standard cell batteries brand



WARRANTY

LEADER guarantees its products from the date of acceptance by the customer.

The respective warranty periods are as follows :

- ▶ LEADER Search : 2 years
- ▶ LEADER Cam : 2 years
- ▶ LEADER Hasty : 2 years
- ▶ LEADER Scan : 2 years
- ▶ LEADER Sentry : 2 years
- ▶ LEADER Sar : 1 year
- ▶ LEADER Volt : 1 year
- ▶ Battery : 1 year or 500 cycles
- ▶ Charger : 1 year

This warranty does not apply where it has been found by our services that the equipment was damaged by :

- ▶ Normal wear due to operation
- ▶ Improper use of the equipment
- ▶ Accidents arising from carelessness
- ▶ Defective maintenance
- ▶ Failure to follow the standards and instructions of the manufacturers
- ▶ Improper storage

Consumables, such as the screen protection window, cases, feet, cables, paint and labels, transport bag, etc. are excluded from the warranty if the defects are discovered after using the product.





ALWAYS IN TOUCH WITH OUR CLIENTS
TO DESIGN THE PRODUCTS YOU WILL
NEED **IN THE FUTURE**



Fire extinction



Mobile ventilation



Thermal imaging



Fire training equipment



Search and Rescue equipment



Foam concentrates & foam proportioning

TEMPEST TECHNOLOGY a Leader Group Company
4708 N. Blythe Ave. Fresno, CA 93722 - U.S.A
Tel: 559.277.7577
www.tempest.us.com
www.LeaderNorthAmerica.com

LEADER GmbH
Zur Fabrik 10 - 66271 Kleinblittersdorf - Germany
Tel. : +49 (0) 6805/60067-0 - Fax : +49 (0) 6805/60067-10
info@leader-gmbh.de

GROUPE LEADER S.A.S.
ZI des Hautes-Vallées - Chemin n° 34 - CS20014 - 76930 Octeville sur Mer - France
Tel +33 (0)2.35.53.05.75 - Fax +33 (0)2.35.53.16.32
info@leader-group.eu

SPAIN / PORTUGAL / LATIN AMERICA
spain.portugal.latinamerica@leader-group.eu

CHINA / HONG KONG / MACAU
china@leader-group.eu

www.LeaderNorthAmerica.com

A  Genetech group company

Design : Valeur Graphique - www.valeurgraphique.com - 05/04/18 - ZCL08.264.US.6

FIRE

FIRE



FIRE EAGLE® AIR

Athletic Feel & Firefighter Strong

Sensation athlétique & robustesse pour les pompiers

Standard classification

NFPA 1971-2013
CAN/CSA-Z195-2014

NFPA 1992-2012
ASTM F 2413-2011

Art. No.:	507502 men/homme
Art. No.:	507503 women/femme
Material:	Waterproof leather/cuir imperméable
Color/Couleur:	black, noir
Leg height/Hauteur:	11 inches
Inside/Intérieur:	CROSSTECH®
Sole/Semelle:	017
Men/Homme:	5 – 16 & half sizes
Women/Femme:	5 – 12 & half sizes
Widths/Largeurs:	Narrow, Medium, Wide

507502, 507503



Climate System

Ankle Protector System

AF System
Ankle Flex System

HD Cap System
High Durability Cap System

ES Out System
Easy Slip Out System

Stabilizer





507101, 507102



Standard classification

NFPA 1971-2013
NFPA 1992-2012
CAN/CSA-Z195-2014
ASTM F 2413-2011

FIRE HERO® XTREME

German engineered like no other boot in the world

Botte d'ingénierie allemande comme aucune autre au monde

Art. No.:	507101 men/homme
Art. No.:	507102 women/femme
Material:	Waterproof leather/cuir imperméable
Color/Couleur:	black, noir
Leg height/Hauteur:	11 inches
Inside/Intérieur:	CROSSTECH®
Sole/Semelle:	01
Men/Homme:	5 – 16 & half sizes
Women/Femme:	5 – 12 & half sizes
Widths/Largeurs:	Narrow, Medium, Wide



FIRE



501605, 501606



Standard classification

NFPA 1971-2013
NFPA 1992-2012
CAN/CSA-Z195-2014
ASTM F 2413-2011

FIRE HUNTER® XTREME

The service boot with the comfort of a lace boot

Botte d'intervention qui se porte comme une botte lacée

Art. No.:	501605 men/homme
Art. No.:	501606 women/femme
Material:	Waterproof leather/cuir imperméable
Color/Couleur:	black, noir
Leg height/Hauteur:	14 inches
Inside/Intérieur:	CROSSTECH®
Sole/Semelle:	011
Men/Homme:	5 – 16 & half sizes
Women/Femme:	5 – 12 & half sizes
Widths/Largeurs:	Narrow, Medium, Wide





506005, 506006



Standard classification

NFPA 1971-2013
NFPA 1951-2013
NFPA 1977-2016
NFPA 1992-2012
CAN/CSA-Z195-2014
ASTM F 2413-2011

FIRE FLASH® XTREME

The clear leader in lace-up firefighting boots

Le chef indéniable en matière de botte de pompier à lacets

Art. No.:	506005 men/homme
Art. No.:	506006 women/femme
Material:	Waterproof leather/cuir imperméable
Color/Couleur:	black, noir
Leg height/Hauteur:	10 inches
Inside/Intérieur:	CROSSTECH®
Sole/Semelle:	011
Men/Homme:	5 – 16 & half sizes
Women/Femme:	5 – 12 & half sizes
Widths/Largeurs:	Narrow, Medium, Wide



502004, 502005



Standard classification

NFPA 1971-2013
NFPA 1992-2012
CAN/CSA-Z195-2014
ASTM F 2413-2011

FIRE HUNTER® USA

Perfect choice for tight budgets

Choix idéal pour les budgets restreints

Art. No.:	502004 men/homme
Art. No.:	502005 women/femme
Material:	Waterproof leather/cuir imperméable
Color/Couleur:	black, noir
Leg height/Hauteur:	11 inches
Inside/Intérieur:	CROSSTECH®
Sole/Semelle:	011
Men/Homme:	5 – 16 & half sizes
Women/Femme:	5 – 12 & half sizes
Widths/Largeurs:	Narrow, Medium, Wide





SPECIAL FIGHTER® USAR

Standard classification

NFPA 1951-2013
 NFPA 1977-2016
 NFPA 1992-2012
 NFPA 1999-2013
 CAN/CSA-Z195-2014
 ASTM F 2413-2011

505204, 505205

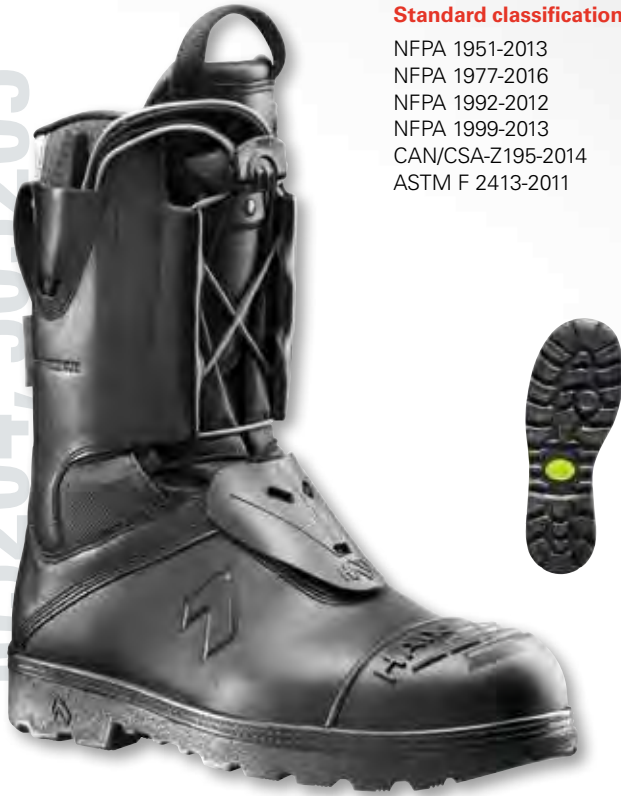

Quad-certified USAR and EMS Boot

Botte à certification USAR et EMS quadrilatérale

Art. No.: 505204 men/homme
 Art. No.: 505205 women/femme
 Material: Waterproof leather & textile, Cuir imperméable & textile
 Color/Couleur: black, noir
 Leg height/Hauteur: 10 inches
 Inside/Intérieur: CROSSTECH®
 Sole/Semelle: 011
 Men/Homme: 5 – 16 & half sizes
 Women/Femme: 5 – 12 & half sizes
 Widths/Largeurs: Narrow, Medium, Wide



MISSOULA

Hiking Boot for Wildland Fire Fighting

Chaussures de randonnée pour lutte contre l'incendie de forêt

Art. No.: 111005
 Material: Nubuck leather/cuir nubuck
 Color/Couleur: black, noir
 Leg height/Hauteur: 8 inches
 Inside/Intérieur: breathable, respirante
 Sole/Semelle: VIBRAM® Sole
 Sizes/Pointures: 5 – 13 & half sizes

111005





EMS / STATION



AIRPOWER® XR1

State of the art Wildland and Station/EMS boot

Bottes à la fine pointe de la technologie pour feux de forêt et station/EMS

Standard classification

NFPA 1999-2013
CAN/CSA-Z195-2014

NFPA 1977-2016
ASTM F2413-2011

Art. No.:	605113 men/homme
Art. No.:	605114 women/femme
Material:	Waterproof leather/cuir imperméable
Color/Couleur:	black, noir
Leg height/Hauteur:	9 inches
Inside/Intérieur:	CROSSTECH®
Sole/Semelle:	012
Men/Homme:	4 ½ – 16 & half sizes
Women/Femme:	5 – 10 & half sizes
Widths/Largeurs:	Narrow, Medium, Wide



605113, 605114



Climate System

Lacing System



AS System
Arch Support System

Protective composite toe cap with TPU cap



Standard classification

NFPA 1999-2013
CAN/CSA-Z195-2014
ASTM F2413-2011

605118, 605119



AIRPOWER® XR2

The newest generation of station and EMS boots

La nouvelle génération de la station et des bottes EMS

Art. No.:	605118 men/homme
Art. No.:	605119 women/femme
Material:	Waterproof leather/cuir imperméable
Color/Couleur:	black, noir
Leg height/Hauteur:	8 inches
Inside/Intérieur:	CROSSTECH®
Sole/Semelle:	012
Men/Homme:	4 ½ – 15 & half sizes
Women/Femme:	5 – 10 & half sizes
Widths/Largeurs:	Narrow, Medium, Wide



EMS/STATION



Standard classification

NFPA 1999-2013
CAN/CSA-Z195-2014
ASTM F 2413-2011

605109, 605110



AIRPOWER® R2

The second generation for EMS & station

La deuxième génération de botte d'EMS et de station

Art. No.:	605109 men/homme
Art. No.:	605110 women/femme
Material:	Waterproof leather/cuir imperméable
Color/Couleur:	black, noir
Leg height/Hauteur:	8 inches
Inside/Intérieur:	CROSSTECH®
Sole/Semelle:	013
Men/Homme:	4 ½ – 15 & half sizes
Women/Femme:	5 – 10 & half sizes
Widths/Largeurs:	Narrow, Medium, Wide



COMBAT READY

THE BEST ATTACK HOSE, GUARANTEED

MADE IN
USA ★

THIS IS KEY

Combat Ready is the double jacket attack line engineered from the inside out — delivering it all, higher flows, superior heat and abrasion resistance and increased durability. Combat Ready combines ring spun polyester staple fibers over an inner lining consisting of a one-piece extruded through-the-weave nitrile/PVC tube — making the tube, jacket liner and cover one complete assembly. This legendary through-the-weave design reduces friction loss while providing superior heat and unmatched kink resistance. Designed for low pressure high volume nozzles, Combat Ready offers high flow capabilities to combat the most aggressive attack situations. The outer jacket is available with double dip “Key-Lok” polyurethane based polymer impregnation for enhanced abrasion and moisture resistance. Features a 10-year warranty, which includes a 1-year warranty on wear and tear.

KEY HOSE

DOUBLE JACKET ATTACK HOSE



THE BEST

ATTACK HOSE

COMBAT READY

DOUBLE JACKET ATTACK HOSE

Diameter	Part No.	Service Test	Proof Test	Coefficient of Flow	Bowl Size	Weight Uncoupled
1 3/4"	DP17-1000	500 psi	1000 psi	6.5	2 1/4"	0.38 lbs/ft
2"	DP20-1000	500 psi	1000 psi	*4.1	2 2/5"	0.44 lbs/ft
2 1/2"	DP25-1000	500 psi	1000 psi	1.8	3"	0.52 lbs/ft

*Coefficient of flow of 4.1 is attained when using 2 1/2" coupling.
The 1 1/2" coupling option has a 5.2 coefficient of flow.

Hose Construction

This hose is designed specifically for aggressive fire attack operations. The outer jacket is woven from ring spun staple polyester yarns over an inner liner consisting of a one-piece extruded through-the-weave nitrile/PVC tube. Color or clear coat abrasion resistant "Key-Lok" process is standard. Combat Ready is manufactured in a high-visibility fashion with two red and two blue stripes running the length of the hose. This heat, abrasion and kink resistant hose shall have superior friction loss characteristics. Lengths available up to 75'. Warranty: Hose shall carry a 10-year written warranty, which includes a 1-year wear/tear warranty.

Inner Hose Properties

When the hose is tested in accordance with NFPA 1961, the liner shall have the following properties:

Ultimate Tensile Strength - Shall not be less than 1200 psi.

Ultimate Elongation - Shall not be less than 200%.

Accelerated Aging Test - Shall meet requirements of UL19 for accelerated aging.

Adhesion - Between reinforcement and liner shall be a minimum of 20 pounds.

Ozone Resistance - Shall show no signs of visible cracking of the cover of liner when tested in accordance with ASTM D1149-91 and ASTM D518-86 (R91), Procedure B.

Chemical Resistance - Exposure to seawater and contamination by most chemicals will have no effect on the short or long term performance of the hose.

Safety Factors

Abrasion Resistance - A direct relationship to the safe performance of the fire hose. The UL abrasion test most closely resembles the fire ground use of fire hose and as such, is considered of prime importance. Hose meeting all of the abrasion resistance safety factors below shall do so without exceeding average weights.

UL Abrasion - The hose shall pass a burst test after 5000 cycles on a reciprocating abrasion tester - as specified in UL Standard 19.

Cold Resistance Safety Factor - Hose shall be capable of safe use down to -50 °F. The hose shall have no apparent damage to cover reinforcement or lining when subjected to the following cold flexibility test: a 50' length of dry hose is coiled and placed in a cold box at -35 °F for a duration of 24 hours. Immediately after removal of the hose from the box, hose should be uncoiled and laid out by one operator.

Flashover Resistance Safety Factor - Heat resistance is of the utmost importance when evaluating interior attack hose. This hose shall meet the safety factors for heat resistance without exceeding the normal fire hose weight. The hose shall be subjected to a static pressure of 100 psi and be capable of withstanding a surface temperature of 1200 °F for a minimum of 30 seconds without bursting.

Water Pick-up Weight - The tendency for a hose to absorb water while in a wet environment can create significant handling difficulties. When tested against the procedure listed in MIL-H-24606 latest edition, the maximum weight gain shall not exceed 3 pounds per 50' length.

Couplings

Combat Ready shall be "doubled ring" with extruded aluminum 6061-T6 USA manufactured couplings. Knurled couplings, 2" x 2 1/2" and other custom features available upon special request.

Colors

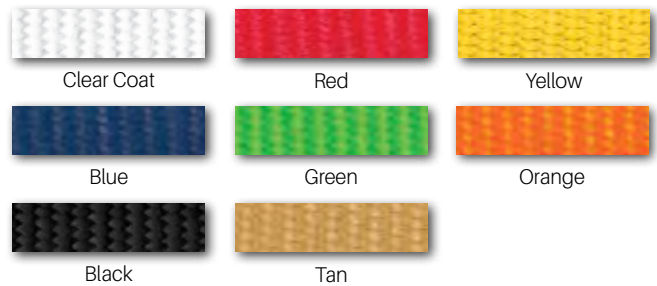

NFPA colors available



Key Hose reserves the right to modify any specification without prior notice to meet or exceed changing standards. For more information please contact a Key Hose authorized distributor. 04/17

THIS IS KEY

PUSHING FIRE HOSE TECHNOLOGY FORWARD

COMBAT SNIPER

Higher Flows. Faster Targeting. Increased Handling.

An operational game-changing attack line with legendary, double jacketed, extruded through-the-weave nitrile/PVC tube construction and true 1.78" diameter. Combat Sniper is engineered for low pressure nozzle applications with targeted flow ranges of 145-175 gpm. This innovative design provides premium kink resistance that allows for precise handling during the push for tight controlled water mapping. Packs on the shoulder as well as it does in the hose bed. Combat Sniper, exclusively from the hose experts at Key.



TARGETED FLOW WITH PRECISE HANDLING



COMBAT SNIPER DOUBLE JACKET ATTACK HOSE

Diameter	Part No.	Service Test	Proof Test	Burst Test	Bowl Size	Weight Uncoupled
1.78"	DP17-100S	500 psi	1000 psi	1500 psi	2.125"	0.40 lbs/ft

Targeted Flow Rates: 145-175 gpm (1.78")

Hose Construction

This hose is designed specifically for aggressive fire attack operations and is recommended for low pressure nozzle applications. The outer jacket is woven from ring spun staple polyester yarns over an inner liner consisting of a one-piece extruded through-the-weave nitrile/PVC tube. Color or clear coat abrasion resistant "Key-Lok" process is standard. Combat Sniper is manufactured in a high-visibility fashion with four black and green stripes running the length of the hose. This heat, abrasion and kink resistant hose shall have superior friction loss characteristics. Lengths available up to 75'. Warranty: Hose shall carry a 10-year written warranty, which includes a 1-year all hazards warranty.

Inner Hose Properties

When the hose is tested in accordance with NFPA 1961, the liner shall have the following properties:

Ultimate Tensile Strength - Shall not be less than 1200 psi.

Ultimate Elongation - Shall not be less than 200%.

Accelerated Aging Test - Shall meet requirements of UL19 for accelerated aging.

Adhesion - Between reinforcement and liner shall be a minimum of 20 pounds.

Ozone Resistance - Shall show no signs of visible cracking of the cover of liner when tested in accordance with ASTM D1149-91 and ASTM D518-86 (R91), Procedure B.

Chemical Resistance - Exposure to seawater and contamination by most chemicals will have no effect on the short or long term performance of the hose.

Safety Factors

Abrasion Resistance - A direct relationship to the safe performance of the fire hose. The UL abrasion test most closely resembles the fire ground use of fire hose and as such, is considered of prime importance. Hose meeting all of the abrasion resistance safety factors below shall do so without exceeding average weights.

UL Abrasion - The hose shall pass a burst test after 5000 cycles on a reciprocating abrasion tester - as specified in UL Standard 19.

Cold Resistance Safety Factor - Hose shall be capable of safe use down to -35 °F. The hose shall have no apparent damage to cover reinforcement or lining when subjected to the following cold flexibility test: a 50' length of dry hose is coiled and placed in a cold box at -65 °F for a duration of 24 hours. Immediately after removal of the hose from the box, hose should be uncoiled and laid out by one operator.

Flashover Resistance Safety Factor - Heat resistance is of the utmost importance when evaluating interior attack hose. This hose shall meet the safety factors for heat resistance without exceeding the normal fire hose weight.

Water Pick-up Weight - The tendency for a hose to absorb water while in a wet environment can create significant handling difficulties. When tested against the procedure listed in MIL-H-24606 latest edition, the maximum weight gain shall not exceed 3 pounds per 50' length.

Inside Diameter

The finished inside diameter of Combat Sniper hose shall be 1.78" respectively, with a tolerance of 1.2% when measured according to UL-19 standards.

Couplings

Combat Sniper shall be supplied with aluminum 6061-T6 USA manufactured couplings. Knurled couplings and other custom features available upon special request. Barcode recess available at additional charge.

Colors

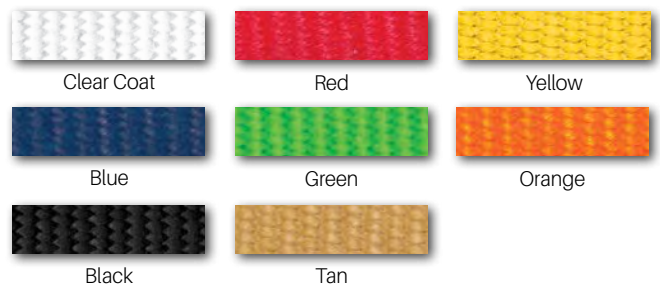

NFPA colors available



Key Hose reserves the right to modify any specification without prior notice to meet or exceed changing standards. For more information please contact a Key Hose authorized distributor. 12/20

TRU-ID

FOR COMMAND AND CONTROL



Featuring True
Internal Diameters

10-Year
Warranty

Lightweight 100%
Polyester Double Jacket

Heavy Duty EPDM
Rubber Liner

Available Diameters:
1 $\frac{3}{4}$ " and 2 $\frac{1}{2}$ "

Mildew
Resistant

MADE IN
USA 

THIS IS KEY

A Combat Classic Reborn

From coast-to-coast, fire departments put out the call for an attack line that will deliver tried and true performance. A hose that will deliver targeted application rates with reduced kink, minimal nozzle whip and specific friction loss. Introducing TRU-ID, the first and only true internal diameter hose specifically designed for combat fire fighting. Classic performance in an innovative design and rugged construction guaranteed to withstand the rigors of the fire ground. Seize the power of targeted flows with command and control performance, specify TRU-ID.



ATTACK HOSE/HANDLINE

FOR COMMAND AND CONTROL



TRU-ID

DOUBLE JACKET RUBBER LINED ATTACK HOSE

Diameter	Part No.	Service Test	Proof Test	Burst Test	Bowl Size	Weight Uncoupled
1.75"	DP17-TRU	400 psi	800 psi	1200 psi	2.125"	0.44 lbs/ft
2.50"	DP25-TRU	400 psi	800 psi	1200 psi	2.8125"	0.56 lbs/ft

Targeted Flow Rates: 125 - 185 gpm (1.75") 200 - 325 gpm (2.50")

Scope

Hose manufactured to this specification shall be of superior quality and workmanship. The hose shall withstand the rough usage of front line fire fighting. Hose specified shall meet NFPA 1961 standards. Hose furnished under these specifications will have a potential service life and warranty of 10 years, barring mistreatment that would render it unfit for service. Upon delivery, the hose shall be free from defects in materials and workmanship.

Jacket Construction

Double jacket hose manufactured to this specification shall be tightly woven with filament polyester yarn in the filler and ring spun polyester yarn in the warp of both the inside and outside jackets. Inside jackets manufactured from 100% filament polyester would not meet minimum standards. The hose shall be resistant to most chemicals and petrol products and resist deterioration due to exposure to UV rays and ozone. Hose shall not be affected by rot or mildew. The inside and outside jackets shall be manufactured with a minimum pick count of 9.5 picks per inch for increased strength and abrasion resistance. Specific tracer lines shall be woven into the outside jacket to visually identify a genuine TRU-ID hose. The hose must be of sufficient body and weight to meet the demands of heavy duty fire fighting usage.

Abrasion

Hose assemblies shall be treated with the special "Key-Lok" polyurethane based polymer impregnation for added abrasion resistance and ease in identification. Impregnated hose shall meet the requirements of MIL-H-24606 latest edition for abrasion resistance. NFPA colors may be specified by the end user. A double dip process for twice the abrasion resistance is available upon request.

Lining

The rubber lining shall be a single-ply extruded tube of synthetic EPDM compounded to resist ozone. The finished form shall be free of pits or other imperfections and have a smooth finish with a minimum wall thickness of .040". No reclaimed rubber shall be used. Plastic tubes that sacrifice durability of the hose life for the sake of weight are not acceptable. TRU-ID is constructed with an ultra smooth, heavy rubber liner to reduce friction loss. Tensile Strength, Ultimate Elongation and Adhesion: Shall meet the standards of Underwriters Laboratories, Inc. as well as all other properties of UL-19 for rubber lined hose. A valid UL/ULC Underwriters inspection procedure shall be in force.

Inside Diameter

The finished inside diameter of TRU-ID hose shall be 1.75" and 2.50" respectively, with a tolerance of 1.2% when measured according to UL-19 standards.

Couplings

TRU-ID hose shall be coupled with 6061-T6 extruded aluminum threaded couplings. TRU-ID mark shall appear on the coupling to identify the genuine TRU-ID assembly. Special threads or other custom features available upon request.



Performance

The minimum burst test pressure when tested in accordance to NFPA 1961 on all TRU-ID hose shall be 1200 psi / 82 bar. Service test pressures stenciled on the hose shall be in accordance with current minimum requirements of NFPA 1962.

Standards

Fire hose manufactured to this specification shall meet and exceed all performance requirements of NFPA 1961 and MIL-H-24606 latest edition standards.

Colors

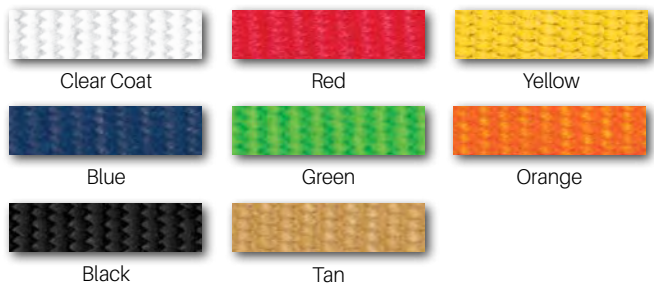

NFPA colors available



Key Hose reserves the right to modify any specification without prior notice to meet or exceed changing standards. For more information please contact a Key Hose authorized distributor. 04/17

KEY-100

LIGHTWEIGHT RUBBER LINED FIRE HOSE

MADE IN
USA



THIS IS KEY

Lightweight, double jacket construction, combining 100% premium ring spun staple and filament polyester fibers over a thin wall, high tensile, EPDM rubber liner. The outer jacket is mildew resistant and available with double dip "Key-Lok" polyurethane based polymer impregnation for abrasion and moisture resistance. A proprietary reverse twill weave construction reduces friction loss, while engineered yarn selections lighten the hose up to 25% compared to competitive offerings. This reliable, double jacket fire hose with Key-Lok treatment is tested to 600 and 800 psi, meets MIL-H-24606 latest edition for abrasion resistance and is UL Listed*. Features a 10-year warranty and lifetime liner delamination guarantee.



DOUBLE JACKET ATTACK/SUPPLY HOSE



RUBBER LINED FIRE HOSE

ECO-10

LIGHTWEIGHT DOUBLE JACKET RUBBER LINED HOSE

Diameter	Part No.	Service Test	Proof Test	Burst Test	Bowl Size	Weight Uncoupled
1"	DP10-800	400 psi	800 psi	1200 psi	1 ³ / ₈ "	0.14 lbs/ft
**1 ¹ / ₂ "	DP15-800-ECO	400 psi	800 psi	1200 psi	1 ¹⁵ / ₁₆ "	0.23 lbs/ft
*1 ³ / ₄ "	DP17-800-ECO	400 psi	800 psi	1200 psi	2 ¹ / ₁₆ "	0.28 lbs/ft
*2"	DP20-800	400 psi	800 psi	1200 psi	2 ² / ₅ "	0.31 lbs/ft
**2 ¹ / ₂ "	DP25-800-ECO	400 psi	800 psi	1200 psi	3"	0.42 lbs/ft
*3"	DP30-800-ECO	400 psi	800 psi	1200 psi	3 ³ / ₈ "	0.56 lbs/ft
4"	DP40-600	300 psi	600 psi	900 psi	4 ¹ / ₂ "	0.82 lbs/ft
5"	DP50-600	300 psi	600 psi	900 psi	5 ¹ / ₂ "	1.14 lbs/ft

*UL Listed to 400 psi | **UL Listed to 400 psi and FM Approved

Scope

Hose manufactured to this specification shall be of superior quality and workmanship. The hose shall withstand the rough usage of front line fire fighting. Hose specified shall meet NFPA 1961 standards. Hose furnished under these specifications will have a potential service life and warranty of 10 years with a lifetime warranty against liner delamination, barring mistreatment that would render it unfit for service. Upon delivery, the hose shall be free from defects in materials and workmanship.

Jacket Construction

Double jacket hose manufactured to this specification shall be tightly woven with filament polyester yarn in the filler and ring spun polyester yarn in the warp of both the inside and outside jackets. Inside jackets manufactured from 100% filament polyester would not meet Eco-10 minimum standards. The hose shall be resistant to most chemicals and petrol products, and resist deterioration due to exposure to UV rays and ozone. It shall not be affected by rot or mildew. Eco-10 double jacket hose may be woven with a double tracer stripe for ease in identification and twist. The inside and outside jackets shall be manufactured with a minimum pick count of 11 picks per inch for increased strength and abrasion resistance. The inside jacket shall be manufactured using a reverse twill process to reduce friction loss. The inside jacket shall be manufactured on a circular loom in a clockwise direction and the outside jacket in a counter-clockwise direction. The hose must be of sufficient body and weight to meet the demands of fire fighting usage.

Abrasion

Hose assemblies shall be available with the special "Key-Lok" polyurethane based polymer impregnation for added abrasion resistance and ease in identification purposes. Impregnated hose shall meet the requirements of MIL-H-24606 latest edition for abrasion resistance. NFPA colors may be specified by the end-user. A double dip process for twice the abrasion resistance is available upon request.

Lining

The rubber lining shall be a single-ply extruded tube of synthetic high tensile EPDM compounded to resist ozone. The finished form shall be free of pits or other imperfections and have a smooth finish for better flow characteristics. Polyurethane tubes, SBR and/or PVC tubes that sacrifice durability of the hose life for the sake of weight are not acceptable. The tube thickness shall be a minimum of .020". The adhesion between the tube and jacket shall meet a minimum requirement of 12 pounds on a 1¹/₂" strip when tested in accordance to UL-19 standards. Minimum tensile strength requirements for the finished tube requirement shall be 1800 psi. A valid UL/ULC Underwriters inspection procedure shall be in force.

Couplings

Eco-10 can be coupled with 6061-T6 aluminum threaded couplings or forged Storz. Brass, special threads or other custom features available upon request. Barcode recess available at additional charge.

Performance

The minimum burst test pressure, when tested in accordance to NFPA 1961, on all Eco-10 diameters up to 3" shall be 1200 psi / 82 bar. Minimum burst test requirements for 4" and 5" diameters shall be 900 psi / 62 bar. Service test pressures stenciled on the hose shall be in accordance with current minimum requirements of NFPA 1962.

*A valid UL/ULC Underwriters 800 psi / 55 bar listing shall be in force. Lengths available up to 100'.

Standards

Fire hose manufactured to this specification shall meet all performance requirements of NFPA 1961 and Underwriters Laboratories standards.

Colors

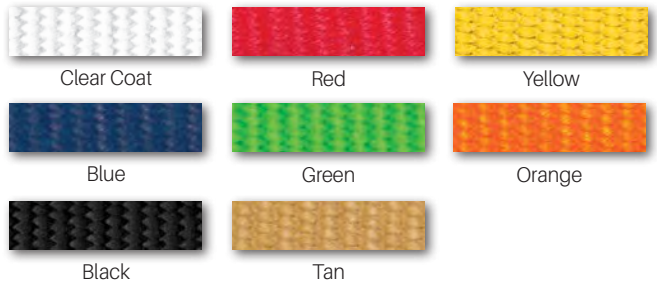

NFPA colors available



Key Hose reserves the right to modify any specification without prior notice to meet or exceed changing standards. For more information please contact a Key Hose authorized distributor. 04/21

BIG-100

HEAVY DUTY RUBBER LINED FIRE HOSE

MADE IN
USA



THIS IS **KEY**

The best in double jacket construction, combining 100% premium polyester filament fibers over a heavy wall, ozone resistant, EPDM rubber liner. The outer jacket is mildew resistant and available with our iconic "Key-Lok" polyurethane based polymer impregnation for maximum abrasion and moisture resistance. Rugged, easy to handle and preferred by metro cities across the US and Canada — available in exclusive FDNY Spec of 1¾". This reliable, double jacket fire hose is UL Listed, tested to 600 and 800 psi and meets MIL-H-24606 latest edition. Features a 10-year warranty and lifetime liner delamination guarantee.



DOUBLE JACKET ATTACK HOSE



RUBBER LINED ATTACK HOSE

BIG-10

HEAVY DUTY DOUBLE JACKET RUBBER LINED ATTACK HOSE

Diameter	Part No.	Service Test	Proof Test	Burst Test	Bowl Size	Weight Uncoupled
*1 1/2"	DP15-800	400 psi	800 psi	1200 psi	1 15/16"	0.34 lbs/ft
*1 3/4"	DP17-800	400 psi	800 psi	1200 psi	2 1/8"	0.38 lbs/ft
1 3/4" FDNY	DP18-800-FDNY	400 psi	800 psi	1200 psi	2 1/4"	0.42 lbs/ft
*2 1/2"	DP25-800	400 psi	800 psi	1200 psi	3"	0.54 lbs/ft
*3"	DP30-800	400 psi	800 psi	1200 psi	3 1/2"	0.74 lbs/ft
*3 1/2"	DP35-600	300 psi	600 psi	900 psi	4 5/16"	0.90 lbs/ft

*UL Listed

Scope

Hose manufactured to this specification shall be of superior quality and workmanship. The hose shall withstand the rough usage of front line fire fighting. Hose specified shall meet NFPA 1961 standards. Hose furnished under these specifications will have a potential service life and warranty of 10 years with a lifetime warranty against liner delamination, barring mistreatment that would render it unfit for service. Upon delivery, the hose shall be free from defects in materials and workmanship.

Jacket Construction

Double jacket hose manufactured to this specification shall be tightly woven with filament polyester yarn in the filler and ring spun polyester yarn in the warp of both the inside and outside jackets. Inside jackets manufactured from 100% filament polyester would not meet Big-10 minimum standards. The hose shall be resistant to most chemicals and petrol products, and resist deterioration due to exposure to UV rays and ozone. It shall not be affected by rot or mildew. The inside and outside jackets shall be manufactured with a minimum pick count of 9.5 picks per inch for increased strength and abrasion resistance. The inside jacket shall be manufactured using a reverse twill process to reduce friction loss. The inside jacket shall be manufactured on a circular loom in a clockwise direction and the outside jacket in a counter-clockwise direction. The hose must be of sufficient body and weight to meet the demands of heavy-duty fire fighting usage.

Abrasion

Hose assemblies shall be available with the special "Key-Lok" polyurethane based polymer impregnation for added abrasion resistance and ease in identification purposes. Impregnated hose shall meet the requirements of MIL-H-24606 latest edition for abrasion resistance. NFPA colors may be specified by the end-user. A double dip process for twice the abrasion resistance is available upon request.

Lining

The rubber lining shall be a single-ply extruded tube of synthetic EPDM compounded to resist ozone. The finished form shall be free of pits or other imperfections and have a smooth finish with a minimum wall thickness of .040". No reclaimed rubber shall be used. Plastic tubes that sacrifice durability of the hose life for the sake of weight are not acceptable. FDNY Lining is constructed with an ultra smooth oversized rubber liner to reduce friction loss. Tensile Strength, Ultimate Elongation and Adhesion: Shall meet the standards of Underwriters Laboratories, Inc. as well as all other properties of UL-19 for rubber lined hose. A valid UL/ULC Underwriters inspection procedure shall be in force.

Couplings

Big-10 shall be coupled with 6061-T6 extruded aluminum threaded couplings or forged Storz. Special threads or other custom features available upon request.

Performance

The minimum burst test pressure, when tested in accordance to NFPA 1961, on all Big-10 diameters up to 3" shall be 1200 psi / 82 bar. Minimum burst test requirements for 3.5" diameter shall be 900 psi / 62 bar. Service test pressures stenciled on the hose shall be in accordance with current minimum requirements of NFPA 1962.

*A valid UL/ULC Underwriters 600 psi / 41 bar - 800 psi / 55 bar listing shall be in force. Lengths available up to 100'.

Standards

Fire hose manufactured to this specification shall meet or exceed all performance requirements of NFPA 1961, Underwriters Laboratories and MIL-H-24606 latest edition standards.

Colors

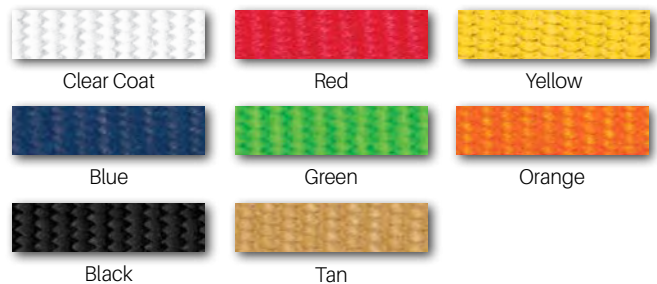

NFPA colors available



Key Hose reserves the right to modify any specification without prior notice to meet or exceed changing standards. For more information please contact a Key Hose authorized distributor. 04/17

KEY-LITE

LIGHTWEIGHT POLYESTER FIRE HOSE

MADE IN
USA ★

THIS IS **KEY**

Ultra light, double jacket construction, utilizing high strength polyester filament fibers to deliver a highly abrasion resistant lightweight attack hose. A dependable, polyurethane lining eliminates ozone deterioration while maintaining lightweight integrity of the hose. The outer jacket is mildew resistant and available with iconic "Key-Lok" polyurethane based polymer impregnation for additional abrasion and moisture resistance. A proprietary reverse twill weave construction reduces friction loss, while ensuring the hose is lighter and easier to maneuver. The Key-Lite lining meets NSF (National Sanitation Foundation) Standard 61 for potable water. This reliable, double jacket fire hose is tested to 600 and 800 psi and meets MIL-H-24606 latest edition. Features a 5-year warranty against liner delamination.

KEY HOSE

DOUBLE JACKET ATTACK HOSE



ATTACK HOSE

KEY-LITE

POLYURETHANE LINED LIGHTWEIGHT DOUBLE JACKET ATTACK HOSE

Diameter	Part No.	Service Test	Proof Test	Burst Test	Bowl Size	Weight Uncoupled
1"	DP10-800-PU	400 psi	800 psi	1200 psi	1 ³ / ₈ "	0.14 lbs/ft
1 ¹ / ₂ "	DP15-800-PU	400 psi	800 psi	1200 psi	1 ¹⁵ / ₁₆ "	0.28 lbs/ft
1 ³ / ₄ "	DP17-800-PU	400 psi	800 psi	1200 psi	2 ¹ / ₈ "	0.30 lbs/ft
2"	DP20-800-PU	400 psi	800 psi	1200 psi	2 ² / ₅ "	0.31 lbs/ft
2 ¹ / ₂ "	DP25-800-PU	400 psi	800 psi	1200 psi	3"	0.46 lbs/ft
3"	DP30-800-PU	400 psi	800 psi	1200 psi	3 ¹ / ₂ "	0.62 lbs/ft
4"	DP40-600-PU	300 psi	600 psi	900 psi	4 ¹ / ₂ "	0.76 lbs/ft

Scope

Hose manufactured to this specification shall be of superior quality and workmanship. The hose shall withstand the rough usage of front line fire fighting. Hose specified shall meet NFPA 1961 standards. Hose furnished under these specifications will have a potential service life and warranty of 5 years, barring mistreatment that would render it unfit for service. Upon delivery, the hose shall be free from defects in materials and workmanship.

Jacket Construction

Double jacket hose manufactured to this specification shall be tightly woven with filament polyester yarn in the filler and ring spun polyester yarn in the warp of both the inside and outside jackets. Inside jackets manufactured from 100% filament polyester would not meet Key-Lite minimum standards. The hose shall be resistant to most chemicals and petrol products, and resist deterioration due to exposure to UV rays and ozone. It shall not be affected by rot or mildew. The inside and outside jackets shall be manufactured with a minimum pick count of 9.5 picks per inch for increased strength and abrasion resistance. The inside jacket shall be manufactured using a reverse twill process to reduce friction loss. The inside jacket shall be manufactured on a circular loom in a clockwise direction and the outside jacket in a counter-clockwise direction. The hose must be of sufficient body and weight to meet the demands of fire fighting usage.

Abrasion

Hose assemblies shall be available with the special "Key-Lok" polyurethane based polymer impregnation for added abrasion resistance and ease in identification purposes. Impregnated hose shall meet the requirements of MIL-H-24606 latest edition for abrasion resistance. NFPA colors may be specified by the end-user. A double dip process for twice the abrasion resistance is available upon request.

Lining

The lining shall be a single-ply extruded tube of synthetic polyurethane to resist ozone. The polyurethane tube shall adhere to the jacket to prevent delamination. The finished lining will meet MIL-H-24606 and NSF-61 standards for potable water use hose. The use of the polyurethane lined fire hose is designed to increase packing ability and reduce weight for fire fighting applications where lightweight fire hose is desired.

Couplings

Key-Lite shall be coupled with 6061-T6 extruded aluminum threaded couplings or forged Storz. Special threads or other custom features available upon request.

Performance

The minimum burst test pressure, when tested in accordance to NFPA 1961, on all Key-Lite diameters up to 3" shall be 1200 psi / 82 bar. Minimum burst test requirements for 4" diameter shall be 900 psi / 62 bar. Service test pressures stenciled on the hose shall be in accordance with current minimum requirements of NFPA 1962. Lengths available up to 100'.

Standards

Fire hose manufactured to this specification shall meet or exceed all performance requirements of NFPA 1961 and MIL-H-24606 latest edition standards.

Colors

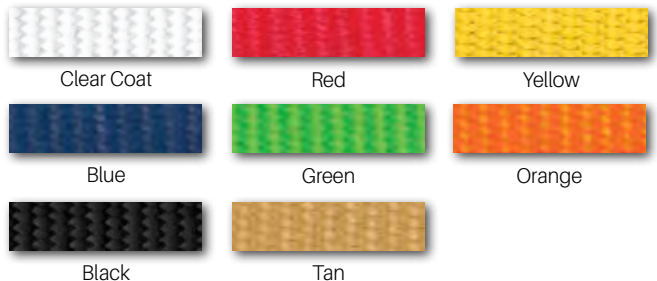

NFPA colors available



Key Hose reserves the right to modify any specification without prior notice to meet or exceed changing standards. For more information please contact a Key Hose authorized distributor. 04/17



HIGH PRESSURE HIGH VISIBILITY

PRO-FLOW HP LARGE DIAMETER RUBBER COVERED SUPPLY HOSE

Diameter	Part No.	Service Test	Proof Test	Burst Test	Bowl Size	Weight Uncoupled
4"	RC40-600	300 psi	600 psi	900 psi	4 1/4"	0.93 lbs/ft
5"	RC50-600	300 psi	600 psi	900 psi	5 1/4"	1.25 lbs/ft

UL Listed up to 200 psi

Hose Construction

Hose shall be made from 100% high tenacity synthetic polyester yarn, circularly woven and completely protected by a through-the-weave extruded PVC/Nitrile rubber, forming a single homogeneous construction without the use of glues or adhesives of any type. Pro-Flow HP features a thin rib construction to aid abrasion resistance. Pro-Flow HP meets or exceeds requirements of NFPA 1961. Pro-Flow HP shall carry a 10-year written warranty against defects in materials and workmanship. Lengths available up to 100'.

Lining Properties

Ultimate Tensile Strength - Tensile strength of the lining and cover shall not be less than 1200 psi.

Ultimate Elongation - 400% minimum.

Accelerated Aging Test - The tensile strength and ultimate elongation of the vulcanized rubber compound which has been subjected to the action of oxygen at a pressure of 300 psi (± 10 psi) and a temperature of 158 °F (± 18 °F) for a period of 96 hours shall retain 60% of its originally stated properties.

Abrasion Resistance

Hose shall withstand 10,000 cycles on the Taber Abrasion Machine (H-22 Wheel: 0.5 kg), without exposing the liner. Key Hose, on request, will supply written warranties that Pro-Flow HP hose meets a minimum 10,000 cycles. Other abrasion test results (UL, DIN, etc.) can be supplied on request of purchaser.

Cold Resistance

Hose shall have a capability of use down to -35 °F. Hose shall have no apparent damage to cover, reinforcement or lining when subjected to the following cold flexibility test: a 50' length of dry hose is to be firmly coiled and placed in a cold box at -35 °F for a duration of 24 hours. Immediately after removal of the hose from the box, hose should be uncoiled and laid out by one operator.

Ozone Resistance

Hose shall show no visible signs of cracking to the lining or cover when tested in accordance to ASTM D518 Procedure B (100 pphm / 118 °F / 70 hours).

Chemical Resistance

Exposure to sea water and contamination by most chemical substances, hydrocarbons, oils, alkalis, acids and greases must have no effect on the short or long term performance of the hose. A chemical resistance chart is available and Key Hose will supply specific chemical resistance data on request of purchaser for unique applications.

Couplings

Pro-Flow HP coupling options are as required by purchaser, expansion ring threaded, Storz clamp ring, etc.

Colors



Hi-Visibility Green



Key Hose reserves the right to modify any specification without prior notice to meet or exceed changing standards. For more information please contact a Key Hose authorized distributor. 06/20

DURA-FLOW

HEAVY DUTY, HIGH PERFORMANCE ATTACK HOSE



THIS IS **KEY**

The lightweight, small diameter, rubber covered attack hose that packs a big punch. The heat and chemical resistant, nitrile/PVC through-the-weave design provides peak performance and maximum flow. With a test pressure of 600 psi and a range of temperature tolerance from -35 °F to 1200 °F, Dura-Flow clearly outperforms conventional rubber covered attack lines. A rugged, thick ribbed outer jacket construction makes the hose highly resistant to kink, impact, punctures, cuts and abrasion. Ozone resistant, maintenance-free and no drying required, make Dura-Flow a reliable weapon in a firefighter's arsenal. NFPA compliant and UL Listed*.



RUBBER COVERED ATTACK HOSE/HANDLINE

RUBBER COVERED ATTACK HOSE



DURA-FLOW

RUBBER COVERED ATTACK HOSE

Diameter	Part No.	Service Test	Proof Test	Burst Test	Bowl Size	Weight Uncoupled
1"	RC10-600	300 psi	600 psi	900 psi	1 ³ / ₁₆ "	0.15 lbs/ft
1 1/2"	RC15-600	300 psi	600 psi	900 psi	1 ¹³ / ₁₆ "	0.24 lbs/ft
1 3/4"	RC17-600	300 psi	600 psi	900 psi	1 ¹⁵ / ₁₆ "	0.28 lbs/ft
2"	RC20-600	300 psi	600 psi	900 psi	2 1/4"	0.32 lbs/ft
2 1/2"	RC25-600	300 psi	600 psi	900 psi	2 ¹³ / ₁₆ "	0.48 lbs/ft

*UL Listed to 500 psi proof test

Hose Construction

Hose shall be made from 100% high tenacity synthetic polyester yarn, circularly woven and completely protected by a through-the-weave extruded PVC/Nitrile rubber, forming a single homogeneous construction without the use of glues or adhesives of any type. Dura-Flow features a raised thick rib construction to aid abrasion resistance. Dura-Flow meets or exceeds all requirements of NFPA 1961 for attack hose. Dura-Flow shall carry a 10-year written warranty against defects in materials and workmanship.

Lining Properties

Ultimate Tensile Strength - Tensile strength of the lining and cover shall not be less than 1200 psi.

Ultimate Elongation - 400% minimum.

Accelerated Aging Test - The tensile strength and ultimate elongation of the vulcanized rubber compound which has been subjected to the action of oxygen at a pressure of 300 psi (±10 psi) and a temperature of 158 °F (±18 °F) for a period of 96 hours shall retain 60% of its originally stated properties.

Abrasion Resistance

Hose shall withstand 10,000 cycles on the Taber Abrasion Machine (H-22 Wheel: 0.5 kg), without exposing the liner. Key Hose, on request, will supply written warranties that Dura-Flow hose meets a minimum 10,000 cycles. Other abrasion test results (UL, DIN, etc.) can be supplied on request of purchaser.

Cold Resistance

Hose shall have a capability of use down to -35 °F. Hose shall have no apparent damage to cover, reinforcement or lining when subjected to the following cold flexibility test: a 50' length of dry hose is to be firmly coiled and placed in a cold box at -35 °F for a duration of 24 hours. Immediately after removal of the hose from the box, hose should be uncoiled and laid out by one operator.

Ozone Resistance

Hose shall show no visible signs of cracking to the lining or cover when tested in accordance to ASTM D518 Procedure B (100 pphm / 118 °F / 70 hours).

Chemical Resistance

Exposure to sea water and contamination by most chemical substances, hydrocarbons, oils, alkalis, acids and greases must have no effect on the short or long term performance of the hose. A chemical resistance chart is available and Key Hose will supply specific chemical resistance data on request of purchaser for unique applications.

Heat Resistance

The hose, when subjected to a static pressure of 100 psi, shall be capable of withstanding a surface temperature of 1200 °F for a minimum of one minute without rupture or damage to the synthetic reinforcement.

Couplings

Dura-Flow coupling options are as required by purchaser, expansion ring threaded, Storz clamp ring, etc.

Performance

The minimum burst test pressure, when tested in accordance to NFPA 1961, on all Dura-Flow diameters shall be 900 psi / 62 bar. Service test pressures stenciled on the hose shall be in accordance with current minimum requirements of NFPA 1962. *A valid UL/ULC Underwriters 500 psi / 34 bar listing shall be in force. Lengths available up to 300'.

Colors



Red



Yellow

Other colors available upon special request



Key Hose reserves the right to modify any specification without prior notice to meet or exceed changing standards. For more information please contact a Key Hose authorized distributor. 08/18

PRO-FLOW

HEAVY DUTY LARGE DIAMETER HOSE



MADE IN
USA



THIS IS KEY

A lightweight, heat resistant, large diameter supply hose that delivers superior flow during fireground operations. Ozone and chemical resistant, the nitrile/PVC through-the-weave design allows the hose to expand under pressure — decreasing friction loss and increasing water flow. The thin rib rubber outer cover offers increased resistance to impact, punctures and abrasion. Reliable, maintenance-free and requires no drying, make this the ideal supply hose for municipal and industrial fire departments. NFPA compliant and UL listed.



LIGHTWEIGHT SUPPLY HOSE



LARGE DIAMETER

PRO-FLOW

LARGE DIAMETER RUBBER COVERED SUPPLY HOSE

Diameter	Part No.	Service Test	Proof Test	Burst Test	Bowl Size	Weight Uncoupled
*3"	RC30-600	300 psi	600 psi	900 psi	3 3/8"	0.60 lbs/ft
*4"	RC40-500	250 psi	500 psi	750 psi	4 1/4"	0.74 lbs/ft
*5"	RC50-450	225 psi	450 psi	675 psi	5 1/4"	0.93 lbs/ft
6"	RC60-450	225 psi	450 psi	675 psi	6 1/4"	1.35 lbs/ft

*UL Listed

Hose Construction

Hose shall be made from 100% high tenacity synthetic polyester yarn, circularly woven and completely protected by a through-the-weave extruded PVC/Nitrile rubber, forming a single homogeneous construction without the use of glues or adhesives of any type. Pro-Flow features a thin rib construction to aid abrasion resistance. Pro-Flow meets or exceeds requirements of NFPA 1961. Pro-Flow shall carry a 10-year written warranty against defects in materials and workmanship. Lengths available up to 100'.

Lining Properties

Ultimate Tensile Strength - Tensile strength of the lining and cover shall not be less than 1200 psi.

Ultimate Elongation - 400% minimum.

Accelerated Aging Test - The tensile strength and ultimate elongation of the vulcanized rubber compound which has been subjected to the action of oxygen at a pressure of 300 psi (± 10 psi) and a temperature of 158 °F (± 18 °F) for a period of 96 hours shall retain 60% of its originally stated properties.

Abrasion Resistance

Hose shall withstand 10,000 cycles on the Taber Abrasion Machine (H-22 Wheel: 0.5 kg), without exposing the liner. Key Hose, on request, will supply written warranties that Pro-Flow hose meets a minimum 10,000 cycles. Other abrasion test results (UL, DIN, etc.) can be supplied on request of purchaser.

Cold Resistance

Hose shall have a capability of use down to -35 °F. Hose shall have no apparent damage to cover, reinforcement or lining when subjected to the following cold flexibility test: a 50' length of dry hose is to be firmly coiled and placed in a cold box at -35 °F for a duration of 24 hours. Immediately after removal of the hose from the box, hose should be uncoiled and laid out by one operator.

Ozone Resistance

Hose shall show no visible signs of cracking to the lining or cover when tested in accordance to ASTM D518 Procedure B (100 pphm / 118 °F / 70 hours).

Chemical Resistance

Exposure to sea water and contamination by most chemical substances, hydrocarbons, oils, alkalis, acids and greases must have no effect on the short or long term performance of the hose. A chemical resistance chart is available and Key Hose will supply specific chemical resistance data on request of purchaser for unique applications.

Heat Resistance

The hose, when subjected to a static pressure of 100 psi, shall be capable of withstanding a surface temperature of 1200 °F for a minimum of one minute without rupture or damage to the synthetic reinforcement.

Couplings

As required by purchaser, expansion ring threaded, Storz clamp ring, etc.

Colors

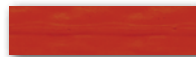

Red



Yellow

Other colors available upon request



Key Hose reserves the right to modify any specification without prior notice to meet or exceed changing standards. For more information please contact a Key Hose authorized distributor. 04/17

POWERHAWK® P4 RESCUE TOOL

Specifications:



With **P4x SPREADERS**



Nominal input:	43.2 VDC
Water rating:	IP66
Rotating Powerhead angle:	61°
Weight without battery or tool attachment:	31.5 lbs (14.3 kg)
Weight with battery and tool attachment:	45 lbs (20.4 kg)
Width:	10.4 in. (264mm)
Height:	10.3 in. (262mm)
Length without tool attachment:	16 in. (406mm)
Length with tool attachment:	23.8 in. (604mm)
Length with tool attachment rotated:	18 in. (457mm)
Spreading distance:	16 in. (406mm)
Forces at tips (1 inch from end):	9,200 to 15,000 lbf (40.9 to 66.7 kN)
Forces at base of removable tips:	13,800 to 38,400 lbf (61.4 to 170.8 kN)
Forces at base of arm teeth:	23,300 to 175,000 lbf (103.6 to 778.4 kN)



With **P4w CUTTER**



Nominal input:	43.2 VDC
Water rating:	IP66
Rotating Powerhead angle:	61°
Weight without battery or tool attachment:	31.5 lbs (14.3 kg)
Weight with battery and tool attachment:	48.5 lbs (22 kg)
Width:	10.4 in. (264mm)
Height:	10.3 in. (262mm)
Length without tool attachment:	16 in. (406mm)
Length with tool attachment:	23.6 in. (604mm)
Length with tool attachment rotated:	20 in. (508mm)
Cutter opening:	5.8 in (147mm)
Max. cutting force:	115,000 lbf (510 kN)

P4 Kit Components & Accessories:



EDD Battery with charge indicator and on/off switch



EDD Battery Charger



EDD 10X Battery Backpack



EDD Power Adapter



Aircraft Spreader Tips



LED Light w/ mounting strap

A NEW ERA
BEGINS IN
BATTERY-POWERED
RESCUE TOOLS

BEYOND HYDRAULICS



ELECTRONIC DIRECT DRIVE TECHNOLOGY

INTRODUCING THE NEW

POWERHAWK®

P4

RESCUE TOOL

THE PIONEER IN BATTERY-POWERED RESCUE TOOLS

POWER HAWK
RESCUE SYSTEMS

In Partnership with **RESQTEC**

POWER HAWK Technologies, Inc.
300 Forge Way, Suite 2, Rockaway, NJ 07866 USA
800-PWR-HAWK or 973-627-4646 Fax: 973-627-4622

www.powerhawk.com

Copyright All of the information and material inclusive of text, images, logos, product names is either the property of, or used with permission by Power Hawk Technologies, Inc (PHT). The information may not be distributed, modified, displayed, reproduced –in whole or in part – without prior written permission by PHT. Trademarks POWER HAWK® and its logo are registered trademarks of Power Hawk Technologies, Inc. RESQTEC® and its logo are registered trademarks of Resqtec Zumro, B.V. Disclaimer All information herein was carefully gathered and examined, however, PHT cannot be held responsible for mistakes or incompleteness of content. PHT may change or modify parts at any time without notification and accepts no liability for the consequences of activities undertaken based on the contents.

POWER HAWK
RESCUE SYSTEMS

In Partnership with **RESQTEC**

THE NEW POWERHAWK® P4

Features..

- HEAVY-DUTY SPREADING and CUTTING in a super compact and totally self-contained Battery-Powered Rescue Tool
- ROTATING POWERHEAD for going around corners and getting into tight spots
- INTERCHANGEABLE Tool Attachments allows the P4 to be converted from a Spreader to a Cutter to a Combi Tool in just seconds!

VERSATILITY SAVES LIVES!



AND

NO HYDRAULICS

MEANS...

- High-Efficiency Direct Power and VERY LONG BATTERY RUN TIMES
- NO captured hydraulic fluid to heat up rapidly, leak and reduce output power

The P4 unites the innovations of POWER HAWK's aerospace gear technology with RESQTEC's latest Electronic Direct Drive (EDD) motor and lithium battery technology, resulting in a super compact and self contained battery powered rescue tool that delivers enormous spreading and cutting power for getting jobs done! Unmatched VERSATILITY and POWER has soared to new heights. Come and experience it for yourself!



The rotating Powerhead of the P4 enables spreading and cutting in tight spots and around corners. In other words, places other rescue tools just cannot go!



Patented Rotating Powerhead



ONE TOOL,
MULTIPLE
OPERATIONS!

Reversible
Tips

Change in Seconds!

P4x
Spreaders

P4w
Cutter

The P4's capability grows! As new Tool Attachments are developed and introduced, simply add them to your P4 arsenal!



Quick change Long lasting Battery with charge indicator and on/off switch



Accessory: 10x battery backpack

The P4 is powered by the latest in Lithium Ion battery technology and conforms to IEC62133 safety standards and the UN 38.3 shipping requirements for lithium batteries. The motor technology leveraged in EDD produces a staggering 1.4kW, similar to a small gasoline engine currently used in hydraulic pumps.

POWERHAWK® P4 RESCUE TOOL

Specifications:



With **P4x SPREADERS**



Nominal input:	43.2 VDC
Water rating:	IP66
Rotating Powerhead angle:	61°
Weight without battery or tool attachment:	31.5 lbs (14.3 kg)
Weight with battery and tool attachment:	45 lbs (20.4 kg)
Width:	10.4 in. (264mm)
Height:	10.3 in. (262mm)
Length without tool attachment:	16 in. (406mm)
Length with tool attachment:	23.8 in. (604mm)
Length with tool attachment rotated:	18 in. (457mm)
Spreading distance:	16 in. (406mm)
Forces at tips (1 inch from end):	9,200 to 15,000 lbf (40.9 to 66.7 kN)
Forces at base of removable tips:	13,800 to 38,400 lbf (61.4 to 170.8 kN)
Forces at base of arm teeth:	23,300 to 175,000 lbf (103.6 to 778.4 kN)



With **P4w CUTTER**



Nominal input:	43.2 VDC
Water rating:	IP66
Rotating Powerhead angle:	61°
Weight without battery or tool attachment:	31.5 lbs (14.3 kg)
Weight with battery and tool attachment:	48.5 lbs (22 kg)
Width:	10.4 in. (264mm)
Height:	10.3 in. (262mm)
Length without tool attachment:	16 in. (406mm)
Length with tool attachment:	23.6 in. (604mm)
Length with tool attachment rotated:	20 in. (508mm)
Cutter opening:	5.8 in (147mm)
Max. cutting force:	115,000 lbf (510 kN)

P4 Kit Components & Accessories:



EDD Battery with charge indicator and on/off switch



EDD Battery Charger



EDD 10X Battery Backpack



EDD Power Adapter



Aircraft Spreader Tips



LED Light w/ mounting strap

A NEW ERA
BEGINS IN
BATTERY-POWERED
RESCUE TOOLS

BEYOND HYDRAULICS



ELECTRONIC DIRECT DRIVE TECHNOLOGY

INTRODUCING THE NEW

POWERHAWK®

P4

RESCUE TOOL

THE PIONEER IN BATTERY-POWERED RESCUE TOOLS

POWER HAWK
RESCUE SYSTEMS

In Partnership with **RESQTEC**

POWER HAWK Technologies, Inc.
300 Forge Way, Suite 2, Rockaway, NJ 07866 USA
800-PWR-HAWK or 973-627-4646 Fax: 973-627-4622

www.powerhawk.com

Copyright All of the information and material inclusive of text, images, logos, product names is either the property of, or used with permission by Power Hawk Technologies, Inc (PHT). The information may not be distributed, modified, displayed, reproduced –in whole or in part – without prior written permission by PHT. Trademarks POWER HAWK® and its logo are registered trademarks of Power Hawk Technologies, Inc. RESQTEC® and its logo are registered trademarks of Resqtec Zumro, B.V. Disclaimer All information herein was carefully gathered and examined, however, PHT cannot be held responsible for mistakes or incompleteness of content. PHT may change or modify parts at any time without notification and accepts no liability for the consequences of activities undertaken based on the contents.

POWER HAWK
RESCUE SYSTEMS

In Partnership with **RESQTEC**

THE NEW POWERHAWK® P4

Features..

- HEAVY-DUTY SPREADING and CUTTING in a super compact and totally self-contained Battery-Powered Rescue Tool
- ROTATING POWERHEAD for going around corners and getting into tight spots
- INTERCHANGEABLE Tool Attachments allows the P4 to be converted from a Spreader to a Cutter to a Combi Tool in just seconds!

**VERSATILITY
SAVES LIVES!**



AND

NO HYDRAULICS

MEANS...

- High-Efficiency Direct Power and VERY LONG BATTERY RUN TIMES
- NO captured hydraulic fluid to heat up rapidly, leak and reduce output power

The P4 unites the innovations of POWER HAWK's aerospace gear technology with RESQTEC's latest Electronic Direct Drive (EDD) motor and lithium battery technology, resulting in a super compact and self contained battery powered rescue tool that delivers enormous spreading and cutting power for getting jobs done! Unmatched VERSATILITY and POWER has soared to new heights. Come and experience it for yourself!



The rotating Powerhead of the P4 enables spreading and cutting in tight spots and around corners. In other words, places other rescue tools just cannot go!



Patented Rotating Powerhead



ONE TOOL,
MULTIPLE
OPERATIONS!

Reversible
Tips

Change in Seconds!

P4x
Spreaders

P4w
Cutter

The P4's capability grows! As new Tool Attachments are developed and introduced, simply add them to your P4 arsenal!



Quick change Long lasting Battery with charge indicator and on/off switch



Accessory: 10x battery backpack

The P4 is powered by the latest in Lithium Ion battery technology and conforms to IEC62133 safety standards and the UN 38.3 shipping requirements for lithium batteries. The motor technology leveraged in EDD produces a staggering 1.4kW, similar to a small gasoline engine currently used in hydraulic pumps.

AUTO CRIB-IT™

Automatic Stabilization Tools



**STABILIZE
IN SECONDS!**

“The Standard”

Model AC-14

*Sold in sets of two
using P/N AC-200*



Taller, Wider for SUVs and Light Trucks

Model AC-17

*Sold in sets of two
using P/N AC-217*



- Piston-actuated for stabilizing vehicles in seconds!
- Automatically re-adjusts and locks during operation
- Can be positioned completely under and parallel to rocker panels to avoid trip hazards and stabilize both side-to-side and front-to-back
- Easily decontaminated



- Super Compact! Leaves space for other vital equipment.
AC-14: 28 in. x 4 in. x 2-3/4 in. (71.1 cm x 10.2 cm x 7 cm)
AC-17: 36 in. x 6 in. x 3 in. (91.4 cm x 15.2 cm x 7.6 cm)
- Taller than most step-chocks
AC-14: 13 inches (33.0 cm) AC-17: 17 inches (43.2 cm)
- Lightweight! Made from high-strength aluminum
AC-14: 14.5 lbs (6.6 kg) AC-17: 23.5 lbs (10.7 kg)
- High Load holding per Auto Crib-It!
AC-14: 2000 lbs (8.9 kN) AC-17: 2800 lbs (12.4 kN)





NT HYBRID LIFTING BAG KITS

RESQTEC[®]

In partnership with
Power Hawk Technologies, Inc.



NT HYBRID LIFTING BAG KITS



28 TON KIT	28 TON KIT w/ 12V AIR COMPRESSOR	56 TON KIT	56 TON KIT w/ 12V AIR COMPRESSOR	77 TON KIT	105 TON KIT	154 TON KIT	210 TON KIT	344 TON KIT	421 TON KIT
------------	-------------------------------------	------------	-------------------------------------	------------	-------------	-------------	-------------	-------------	-------------

KIT ITEM DESCRIPTION	PART NO.	NTK-28T	NTK-28T-C	NTK-56T	NTK-56T-C	NTK-77T	NTK-105T	NTK-154T	NTK-210T	NTK-344T	NTK-421T
NT2 HYBRID LIFTING BAG w/ CASE	8508.0002	1	1	2	2		1		2		
NT4 HYBRID LIFTING BAG w/ CASE	8508.0004					1	1	2	2		1
NT8 HYBRID LIFTING BAG w/ CASE	8508.0008									2	2
REGULATOR w/ 7 FT FIXED HOSE	8700.0571	1		1		1	1	1	1	1	1
CONNECTABLE HANDHELD DUAL CONTROLLER	8700.0552	1	1	1	1	1	1	1	1	1	1
DELIVERY HOSE, 26FT RUBBER (R,Y,G,B)	8700.13xx	1	1	2	2	1	2	2	4	2	3
SHUT OFF HOSE, 7FT RUBBER (R,Y,G,B)	8700.13xx	1	1	2	2	1	2	2	4	2	3
SOLID QUICK CONNECTOR	8700.2050			1	1		1	1	2	1	2
CONNECTOR KEY	8700.2008	1	1	1	1	1	1	1	1	1	1
POWER PLATE	8420.0060	1	1	1	1	1	2	2	2	2	2
PLUG, POWER PLATE	8700.2075	1	1	1	1	1	2	2	2	2	2
ACCESSORY STORAGE CASE	8700.0795	1	1	1	1	1	1	1	1	1	1
PORTABLE 12V AIR COMPRESSOR w/ SUPPLY HOSE	LBK-ARB12X2		1		1						



NT HYBRID Lifting Bag with Case



Regulator with Fixed Hose



Handheld Dual Controller



Power Plate



Portable 12V DC Air Compressor with Supply Hose



Quick Connector



Connector Key



Power Plate Plug



Delivery and Shut-off Hoses (Rubber)

Accessory Storage Case



See separate NT HYBRID Lifting Bag brochure for Kit Item specifications

RESQTEC[®]

WWW.RESQTEC.COM

In partnership with

POWER HAWK Technologies, Inc.

300 Forge Way, Suite 2, Rockaway, New Jersey 07866
1-800-PWR-HAWK (797-4295) or 973-627-4646
www.powerhawk.com



CRIBBLOCKS

ALL ROUND STABILIZATION EQUIPMENT

RESQTEC[®]

In partnership with
Power Hawk Technologies, Inc.

WWW.RESQTEC.COM



CRIBBLOCKS

ALL ROUND STABILIZATION EQUIPMENT



CribBlocks are used for stabilization of an object or to support in lifting objects during rescue operations. The unique interlocking system of the CribBlocks allow for creating a variety in stabilization structures with ease.

The reversibility of the CribBlocks can create a flat surface ideal for lifting purposes. Highest quality polyethylene with 60 tons of capacity, splinter free and no absorption of fluids.

Quickly stabilize and follow the load of an object during lifting or use it for quick stabilization during extrication. The rapid stair follows the load in stages of 1/32" offering controlled stabilization.



	CB 40	CB 80	CB 600	WEDGE	SADDLE WEDGE	RAPID STAIR	CONNECTORS	TRANSPORT & STORAGE BOX
Dimensions	7.9" x 7.9" x 1.6"	7.9" x 7.9" x 3.2"	23.6" x 7.9" x 3.2"	7.9" x 7.9" x 3.5"	7.9" x 7.9" x 3.7"	24.6" x 7.9" x 10.2"	4.8" x 1.6" x 0.6"	24" x 16" x 11"
Weight	4 lbs	5.5 lbs	17.4 lbs	3.5 lbs	4.4 lbs	14.3 lbs	0.2 lbs	5.5 lbs



USA OFFICE
 300 Forge Way, Suite 2
 Rockaway, New Jersey, 07866
 T +1 973 627 4646 F +1 973 627 4622

EUROPEAN OFFICE
 Meer en Duin 82
 2163 HC Lisse, the Netherlands
 T +31 (0)252 419002 F +31 (0)252 411794

RESQTEC[®]
 In partnership with
Power Hawk Technologies, Inc.
WWW.RESQTEC.COM

Copyright All of the information and material inclusive of text, images, logos, product names is either the property of, or used with permission by Resqtec. The information may not be distributed, modified, displayed, reproduced – in whole or in part – without the prior written permission by Resqtec.
Trademarks Resqtec, its logos and other Resqtec products and services referenced herein are trademarks of Resqtec, and may be registered in certain jurisdictions. All other product names, company names, marks and logos referenced may be trademarks of their respective owners. Hurst and Jaws of Life are the registered trademarks of Hurst Jaws of Life, Inc.
Disclaimer All information herein was carefully gathered and examined. However, we cannot be held responsible for eventual mistakes or incompleteness. Resqtec may exercise the right to change or modify parts at any time without notification. The content may be subject to error, revision and technical modifications. Resqtec accepts no liability for the consequences of activities undertaken based on the contents.



PROFIX MAX

POWERFUL AND MODULAR STRUT

RESQTEC[®]

In partnership with
Power Hawk Technologies, Inc.

WWW.RESQTEC.COM

PROFIX MAX

MOST POWERFUL AND MODULAR STRUT

The ProFix Max is an integrated and easy to use shoring device with a powerful 16.5 US tons capacity at a safety factor 4:1. It can be operated manually, pneumatically and even hydraulic (in combination with the ram). With just a few struts and attachments unlimited applications are available. Use it for structural, trench, stabilization and lift support. The ProFix Max is a powerful and versatile necessity for rescue teams.

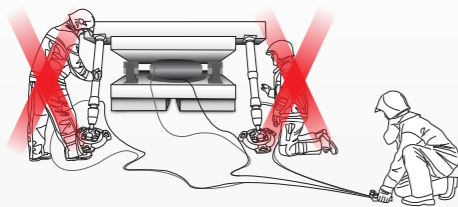

The automatic locking system of the ProFix Max makes shoring and stabilizing loads easy as breathing. Add the pneumatic functionalities of the ProFix Max and every rescuer can operate the struts safely out of range. Working in the danger zone, right underneath the load, is no longer needed.



ProFix Max is telescopic; it provides automatic mechanical locking in any position for ease of use and operation

- 16.5 US tons capacity at safety factor 4:1
- Structural, trench, stabilization and lift support
- A few struts + extensions = unlimited applications
- Pneumatic and mechanical operation



By adding the Multi-Swivel and a PowerPlate, your ProFix Max is provided with extra grip and new possibilities to use chains, ratchet straps or earth nails to fix it firmly.

Height indicators assure the maximum height is not exceeded during a lifting procedure.



The ProFix Max provides 11 US ton lifting capacity by integration of the ram.



The Flow Starts Here

Powerful, Portable, Pumps



MANUFACTURING

Since 1908

Call us Today at 800-567-2719
or view our website at fire-pump.com



PPF = Portable Fire Pump
HND = Honda Gas Engine
VGD = Vanguard Gas Engine
KHL = Kohler Gas Engine
DSL = Diesel Engine
MR = Mid-Range
M = Manual Pull Start
E = Electric Push Button Start
Twin = Two Impellers
1D = One Discharge Line
2D = Two discharge Lines

High-Volume Pumps

Our Products are Designed in use of Fire and Emergency Environments



PFP-9hp-DSL

335 GPM @ 10 PSI
150 GPM @ 50 PSI
70 GPM @ 75 PSI



PFP-9hpHND-M

200 GPM @ 25 PSI
100 GPM @ 75 PSI
60 GPM @ 100 PSI



PFP-9hpHND-EM

200 GPM @ 25 PSI
100 GPM @ 75 PSI
60 GPM @ 100 PSI



PFP-10hp-DSL

250 GPM @ 10 PSI
165 GPM @ 50 PSI
70 GPM @ 85 PSI



PFP-11hp-HND-M

290 GPM @ 10 PSI
120 GPM @ 75 PSI
80 GPM @ 100 PSI



PFP-11hp-HND-EM

290 gpm at 10 PSI
120 gpm at 50 PSI
80 gpm at 100 PSI



PFP-18hpVGD-1D

390 GPM @ 25 PSI
130 GPM @ 100 PSI
45 GPM @ 125 PSI



PFP-18hpVGD-1D-CE

390 GPM @ 25 PSI
130 GPM @ 100 PSI
45 GPM @ 125 PSI



PFP-18hpVGD-2D

370 GPM @ 25 PSI
250 GPM @ 50 PSI
15 GPM @ 125 PSI



PFP-18hpVGD-2D-CE

370 GPM @ 25 PSI
250 GPM @ 50 PSI
15 GPM @ 125 PSI



PFP-20hpHND-1D

550 GPM @ 10 PSI
390 GPM @ 50 PSI
295 GPM @ 75 PSI



PFP-20hpHND-2D

485 GPM @ 10 PSI
300 GPM @ 50 PSI
210 GPM @ 75 PSI



PFP-20hpKHL-1D

485 GPM @ 10 PSI
140 GPM @ 100 PSI
65 GPM @ 125 PSI



PFP-20hpKHL-2D

490 GPM @ 10 PSI
165 GPM @ 100 PSI
90 GPM @ 125 PSI



PFP-23hpVGD-1D

560 GPM @ 10 PSI
200 GPM @ 100 PSI
125 GPM @ 125 PSI



PFP-23hpVGD-2D

550 GPM @ 10 PSI
330 GPM @ 50 PSI
50 GPM @ 125 PSI



PFP-27hp-2D

485 GPM @ 25 PSI
170 GPM @ 100 PSI
85 GPM @ 125 PSI



PFP-30hpKHL-2D

535 GPM @ 10 PSI
250 GPM @ 75 PSI
55 GPM @ 125 PSI

re-li-a-ble
/rə'liəb(ə)l/
adjective

- consistently good in quality or performance; able to be trusted
- a person or thing with trustworthy qualities



The Flow Starts Here
Powerful, Portable, Pumps

MANUFACTURING
Since 1908



PFP = Portable Fire Pump
 HND = Honda Gas Engine
 VGD = Vanguard Gas Engine
 KHL = Kohler Gas Engine
 DSL = Diesel Engine
 MR = Mid-Range
 M = Manual Pull Start
 E = Electric Push Button Start
 Twin = Two Impellers
 1D = One Discharge Line
 2D = Two discharge Lines

Mid-Range Pumps

Our Products are Designed for use in Fire and Emergency Environments



PFP-20hpHND-MR

290 GPM @ 50 PSI
 190 GPM @ 100 PSI
 45 GPM @ 200 PSI



PFP-21hp-DSL-MR

275 GPM @ 10 PSI
 160 GPM @ 100 PSI
 60 GPM @ 175 PSI



PFP-18hpVGD-MR

255 GPM @ 25 PSI
 220 GPM @ 50 PSI
 30 GPM @ 175 PSI



PFP-18hpVGD-MR-CE

255 GPM @ 25 PSI
 220 GPM @ 50 PSI
 30 GPM @ 175 PSI



PFP-23hpVGD-MR

285 GPM @ 10 PSI
 195 GPM @ 100 PSI
 35 GPM @ 225 PSI



PFP-25hp-DSL-MR

315 GPM @ 10 PSI
 230 GPM @ 100 PSI
 105 GPM @ 175 PSI

High-Pressure Pumps

Our Products are Designed for use in Fire and Emergency Environments



PFP-6hpHND-EM-Twin

70 GPM @ 10 PSI
 45 GPM @ 100 PSI
 35 GPM @ 125 PSI



PFP-6hpHND-M-Twin

70 GPM @ 10 PSI
 45 GPM @ 100 PSI
 35 GPM @ 125 PSI



PFP-9hpHND-M-Twin

70 GPM @ 10 PSI
 55 GPM @ 100 PSI
 40 GPM @ 125 PSI



PFP-9hpHND-EM-Twin

70 GPM @ 10 PSI
 55 GPM @ 100 PSI
 40 GPM @ 125 PSI



PFP-11hpHND-EM-HP

65 GPM @ 100 PSI
 35 GPM @ 150 PSI
 5 GPM @ 200 PSI



PFP-11hpHND-M-HP

100 GPM @ 50 PSI
 35 GPM @ 150 PSI
 5 GPM @ 200 PSI



PFP-18hpVGD-HP

115 GPM @ 50 PSI
 70 GPM @ 150 PSI
 20 GPM @ 250 PSI



PFP-20hpHND-HP

140 GPM @ 50 PSI
 60 GPM @ 200 PSI
 25 GPM @ 275 PSI



PFP-20hpKHL-HP

145 gpm at 50 psi
 90 gpm at 150psi
 20 gpm at 275 psi



PFP-23hpVGD-HP

140 GPM @ 50 PSI
 90 GPM @ 150 PSI
 25 GPM @ 275 PSI

Cart Pump

- Deliver water by placing the intake hose/strainer into a lake, pond, swimming pool etc.
- The Cart Pump can deliver a fast fire fighting stream of **70 GPM @ 10PSI, 65 GPM @ 50 PSI, 45 GPM @ 100 PSI, and 35 GPM @ 125 PSI** in difficult to access areas, as well as aid with drafting and water re-supply operations.
- A useful piece of equipment for fire departments, industrial fire brigades, and even residential use, commercial marinas and more.



The Flow Starts Here
 Powerful, Portable, Pumps

MANUFACTURING
 Since 1908



PFP = Portable Fire Pump
 HND = Honda Gas Engine
 VGD = Vanguard Gas Engine
 KHL = Kohler Gas Engine
 DSL = Diesel Engine
 MR = Mid-Range
 M = Manual Pull Start
 E = Electric Push Button Start
 Twin = Two Impellers
 1D = One Discharge Line
 2D = Two discharge Lines

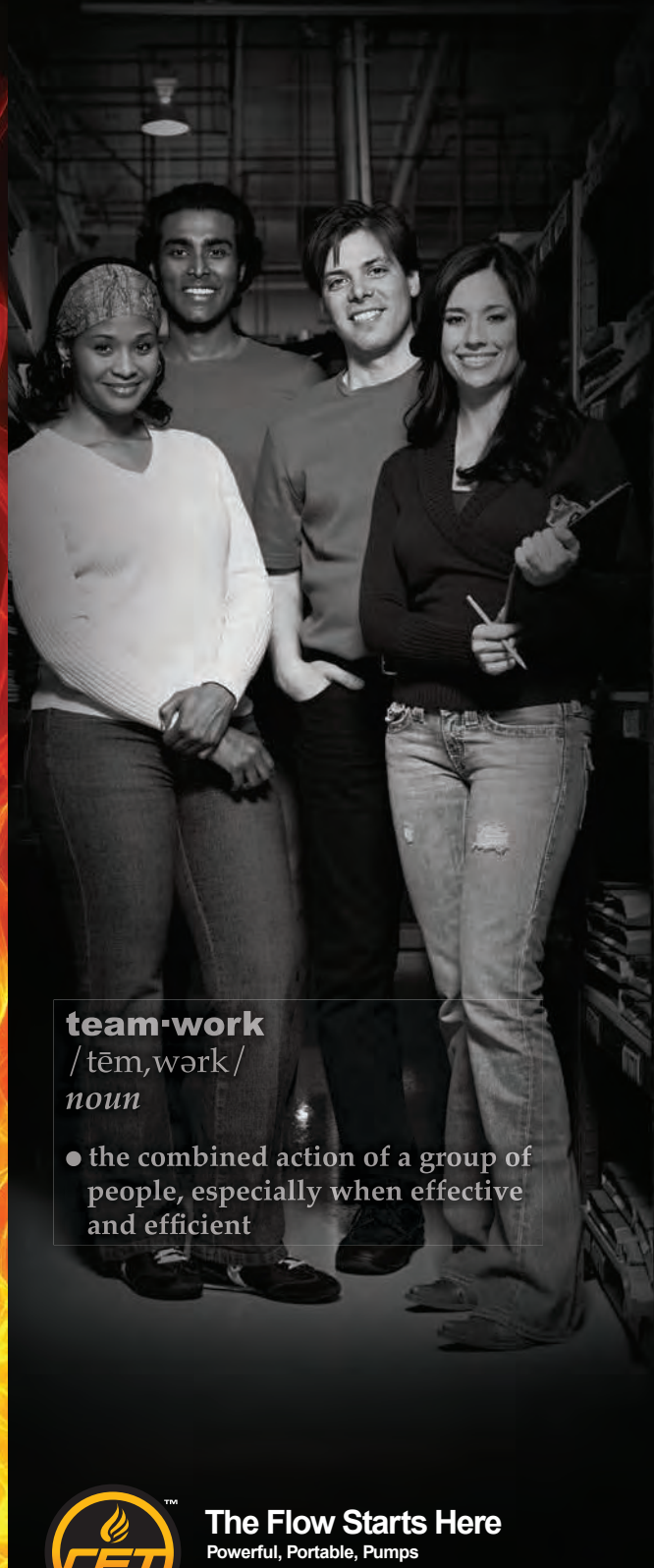

team-work
 / tēm, wɔrk /
 noun

- the combined action of a group of people, especially when effective and efficient

High-Pressure Volume Pumps

Our Products are Designed for use in Fire and Emergency Environments



PFP-20hpKHL-MR

265 GPM @ 50 PSI
 140 GPM @ 150 PSI
 60 GPM @ 200 PSI



PFP-25hp-DSL

425 GPM @ 25 PSI
 150 GPM @ 100 PSI
 40 GPM @ 150 PSI



PFP-38hpKHL-MF

475 GPM @ 25 PSI
 240 GPM @ 100 PSI
 135 GPM @ 150 PSI



PFP-38hpKHL-2D

620 GPM @ 25 PSI
 300 GPM @ 100 PSI
 140 GPM @ 150 PSI



PFP-46hpVW-MF

700 GPM @ 10 PSI
 400 GPM @ 100 PSI
 85 GPM @ 250 PSI



PFP-46hpVW-2D

685 GPM @ 10 PSI
 365 GPM @ 100 PSI
 130 GPM @ 200 PSI



PFP-57hpVW-DSL

730 gpm at 10 psi
 415 gpm at 150psi
 25 gpm at 200 psi



PFP-99hp-DSL

940 GPM @ 10 PSI
 575 GPM @ 150 PSI
 350 GPM @ 200 PSI

De-Watering Pumps

Our Products are Designed for use in Fire and Emergency Environments



PFP-5hpHND-DW

200 GPM @ 10 PSI
 100 GPM @ 35 PSI
 15 GPM @ 60 PSI



PFP-14hpKHL-1D

375 GPM @ 5 PSI
 200 GPM @ 50 PSI
 90 GPM @ 75 PSI

Floating Pumps

Our Products are Designed for use in Fire and Emergency Environments



PFP-6hp-FL

265 GPM @ 5 PSI
 125 GPM @ 15 PSI
 75 GPM @ 20 PSI



PFP-11hpHND-FL

325 GPM @ 10 PSI
 125 GPM @ 50 PSI
 35 GPM @ 70 PSI



The Flow Starts Here
 Powerful, Portable, Pumps

MANUFACTURING
 Since 1908



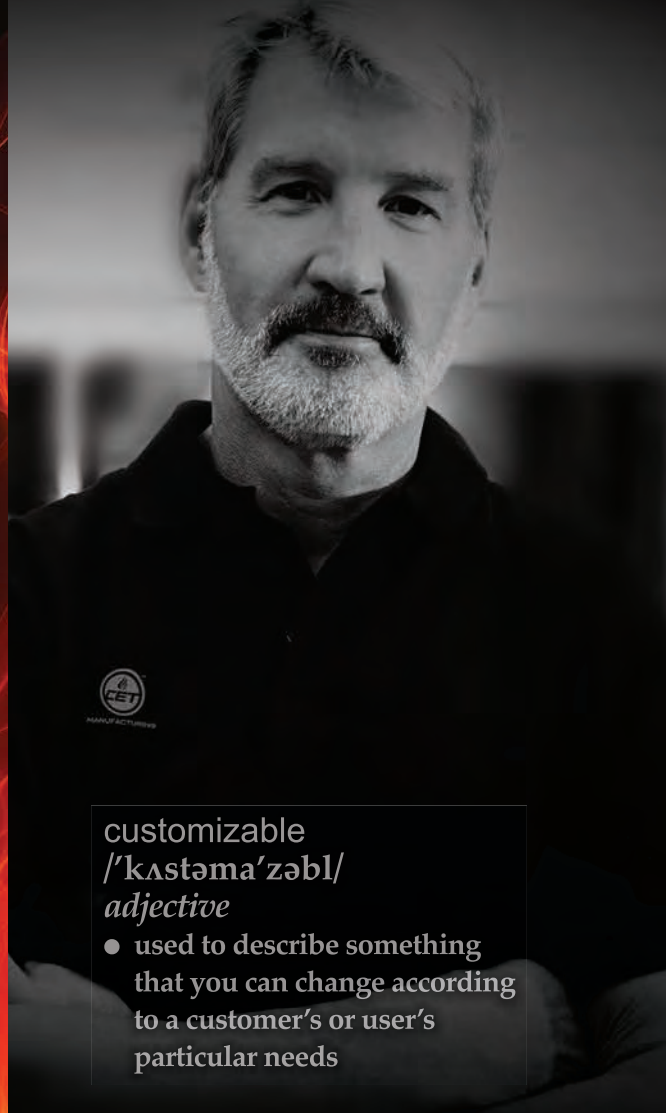

customizable
/'kʌstəmə'zəbl/
adjective

- used to describe something that you can change according to a customer's or user's particular needs

We build our Skid Units with only the best components available on the market. Our Skid Units are built with many standard features and a multitude of options to choose from to customize your own unit. Finally, every single skid units is inspected and tested to make sure the product you receive meets your expectations.

- CET designs, engineers and manufactures our skid units from the ground up
- Customizable to meet your needs
- ISO 9001 Certified
- Know-How + Dependability + Efficiency = solid product at an affordable price.

Quick Delivery Skid Units Models



Attack Pac



Sets the standard for Skid Unit mobile fire attack for firefighting agencies in more than 44 countries.

Econo Pac



Simple to operate, great for ranchers, farmers, homeowners in wild land interface areas and smaller fire agency vehicles.

Forest Pac



Great for Wild and Forestry fire fighting with larger capacity NFPA tank.

Ready Pac



Features popular 6hp-Twin pump and is similar to Attack Pac, but without Booster Reel. Great for urban interface firefighting... car fires, dumpster fires and small room & contents fires.

Skeeter Space Pac



Small and nimble, great for firefighting/ EMS use on ATV and UTV vehicles when navigating through large crowds of people at events, or in remote areas where pick-up size trucks are too big to go through.



The Flow Starts Here
Powerful, Portable, Pumps

MANUFACTURING
Since 1908



crafts·man·ship
/kraf(t)smən'SHip/
noun

- skill in a particular craft
- the quality of design and work shown in something made by hand; artistry



The Flow Starts Here
Powerful, Portable, Pumps

MANUFACTURING
Since 1908

CET Quick Attack Units

Ford Cab & Chassis

- Designed, engineered and manufactured with CET craftsmanship and pride from the ground up.
- No two CET Brush Trucks are exactly alike because no two fire departments are exactly alike. Highly customizable-CET makes our trucks to meet your fire departments specific needs.
- Reliable, dependable, rugged
- ISO 9001 certified



know-how

\ˈnō-,hau\
noun

- knowledge of how to do something well
- knowledge of how to do something smoothly and efficiently

The **CET CAFS** provides a self-contained, gasoline powered, "slide-in" type compressed air foam system (CAFS) unit.

The CAFS unit is designed to fit into the back of a standard length and width pick-up truck body, to discharge water only, air only or compressed air foam from the same discharge outlet. In addition, the consistency of the compressed air foam (expansion ratio), wet/dry is fully adjustable.



The Flow Starts Here
Powerful, Portable, Pumps

MANUFACTURING
Since 1908

Compressed Air Foam System **CAFS**



Advantages of A CET CAFS

- Completely designed, engineered and manufactured by CET craftsmen
- Smart design means ease of use and ease in training
- ISO 9001 Certification
- Great when used with wild land/urban interface attack
- Class A foam increases efficiency and conservation of water supply.





ef-fi-cient
/ə'fɪʃHənt/
adjective

- achieving maximum productivity with minimum wasted effort or expense
- working in a well-organized and competent way

CET Fire Pumps manufactures a variety of foam trailers from 150 to 2,000 gallons. These versatile trailers are ideal for use in industrial, commercial, municipal and forestry environments. Foam trailers provide a very effective tool for airport fuel storage and power plant installations.

- Completely designed, engineered and manufactured by CET craftsmen
- ISO 9001 Certification
- Customizable to your specific needs
- Know-How + Dependability + Efficiency = solid product at an affordable price.
- Class A Foam and Class B Foam increases efficiency and conservation of water supply

Customize Your **Foam** Trailer



**500 Gallons
Foam Trailer**



**1000 Gallons
Foam Trailer**



**1000 Gallons
Re-supply Foam Trailer**



**A & B Foam Trailers
with Two Monitors**



**Single Tote
Foam Trailer**



**Dual Tote
Foam Trailer**



The Flow Starts Here
Powerful, Portable, Pumps

MANUFACTURING
Since 1908





in-no-va-tive

*/'inə,vādiv/
adjective*

- introducing new ideas; original and creative in thinking.

CET offers quality and value with a unique Glider Kit program. Brush truck to Quick-Attack. Engineered, manufactured and assembled for your convenience. A Glider Kit is composed of a CET drop-in, CET polypropylene or aluminum compartments and a CET custom heavy duty Fire Application flatbed.

Advantages of A CET Glider Kit

- The Glider Kit package can be installed on a cab and chassis with supplied "U" bolts, Teflon "Dielectric" pads and brackets. This design allows the body and flatbed to withstand greater levels of stress that can distort other commercial style flat-beds. A truly "OFF ROAD" flatbed!
- A modular design allows removal from the chassis for major repair or mounting on a new chassis.
- The flatbed design offers unmatched, exclusive, CET features.
- Components are pre-assembled, pre-plumbed, pre-wired, and shipped to the OEM in a self-contained, tested unit.
- One manufacturer, one shipment to track, one service and warranty source.
- Quick delivery program.

Quality and Value Every Time



The Flow Starts Here
Powerful, Portable, Pumps

MANUFACTURING
Since 1908



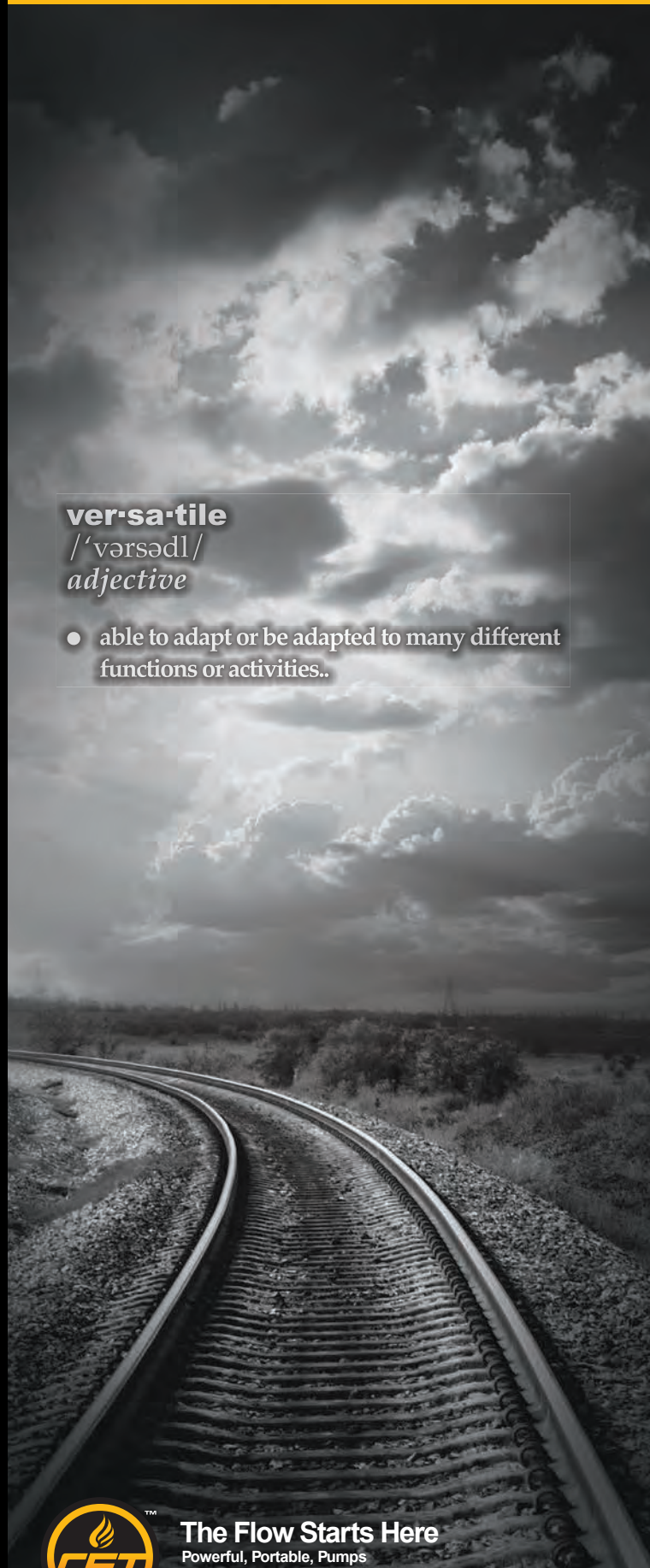

ver-sa-tile
/ˈvɜrsədɪl/
adjective

- able to adapt or be adapted to many different functions or activities..



Agriculture

CET products are routinely used for irrigation to move water where it is needed as well as application of the water. Cleaning of livestock pens, and wash down of animals as well as fire suppression are just a few notable uses.



Concrete

The possibility of mounting CET portable pumps on individual mixer trucks allows for immediate clean up after delivering concrete which saves fuel and time as the drivers then don't have to return to a centralized location for clean up – which allows for more deliveries or the course of days, weeks months and years.



Fire Fighting

Originally made for municipal fire fighting agencies, CET pumps can aid private sector companies with loss prevention by giving those companies quick fire response capability in remote locations where response time by government fire fighting agencies may be hampered by distance or environment/geographic obstacles.



Forestry

Timber related companies or agencies operating in remote woodland locations can benefit from the innovations, and rugged designs of CET



Marine

CET is well suited to aid the marine industries by providing pumps for fire boat operations, de-watering operations to get water out of the hull, to providing portable wash down capabilities.



Mining

CET's rugged portability has helped the mining industry with wash down of mining trucks and equipment, fire fighting at any level of a mine, de-watering to access submerged areas or equipment and more.



Petro-Chem

CET pumps provide versatility. With one purchase a CET pump can provide remote fire fighting and wash down capability, de-watering and water movement all in one unit. A good value for any company.



Race Track Safety

Whether rescuing a race car driver, protecting against fire in the food vendor section of any venue, or de-watering an infield, CET is there to help.



Railroads

The rail industry uses CET pumps and equipment for many of the reasons listed for other industries in general, but additionally, rail road companies apply CET pumps and foam systems on maintenance cars while working on the tracks to help prevent grass fires that routinely start due to sparks etc. caused by everyday operations in the field.



The Flow Starts Here
Powerful, Portable, Pumps



Know What You're Getting Into.®

3 **4** **0**

COR

 **Kappler**®

JUNE 2018



Zytron
100

Zytron
100XP



Two Excellent Fabric Choices For Dry Particulates To Light Splash.

- Ideal where workers need to be protected against hazardous particles or light chemical exposure.
- Excellent holdout against a range of common chemical hazards.
- Zytron 100XP offers greater fabric strength when needed.
- Bound seam styles include storm flap with pressure sensitive closure.
- Applications: Acid handling, tank cleaning, petrochemical operations, agrichemical mixing/applications.



Zytron 100 and 100XP Specific Chemicals Tested*

Chemical	Minutes	
	100	100XP
1,2-Dihydroxyethane	>480	>480
Aqua Fortis	NT	>480
Battery Acid	>480	>480
Black Liquor	>480	>480
Caustic Soda	>480	>480
Chromic Acid	>480	>480
Ethylene Glycol	>480	>480
Formaldehyde	>480	NT
Glutaric Dialdehyde	>480	>480
Gluteraldehyde	>480	>480
Green Liquor	>480	NT
Hydrofluoric Acid 48%	>480	>480
Hydrogen Peroxide	>480	NT
Methylene Oxide	>480	NT
Nitric Acid	NT	>480
Orthophosphoric Acid	NT	>480
Phosphoric Acid	NT	>480
Potassium Cyanide	>480	NT
Sodium Chloride Oxide	>480	NT
Sodium Hydroxide	>480	>480
Sodium Hypochlorite	>480	NT
Sulfuric Acid	>480	>480
White Liquor	>480	NT

* Industrial chemical testing was conducted in accordance with ASTM F 739 with normalized breakthrough times reported in minutes. For detailed technical data and physical properties see page 30 or visit kappler.com.

Zytron® 100/100XP



Shown above are typical garment types for this fabric. View standard styles at kappler.com and see page 29 for custom options.



Hooded coverall styles feature LongNeck™ extended neck design.

Zytron 100XP offers enhanced fabric strength.

ChemTape® is an essential accessory for most chemical scenarios – see page 26 for details.

Both Zytron 100 and 100XP hold out many common industrial hazards.



ChemScan® labels – quick, accurate and only from Kappler.
Scan the label with your phone's QR reader for a complete list of chemicals tested against your garment's protective fabric.

Zytron 200

When You Need More Strength And A Wider Range Of Protection.

- Offers protection from an expanded range of chemicals.
- Styles available with both bound and heat sealed/taped seams.
- Stronger fabric especially valuable where rip-out is a concern – offers greater physical strength for more demanding work applications.
- Applications: Chemical handling, petrochemical operations, hazardous material clean-up and remediation.



Zytron 200

Specific Chemicals Tested*

Chemical	Minutes
Acetic Acid	>480
Acetonitrile	52
Acrylonitrile	65
Aniline	>480
Battery Acid	>480
Benzene	36
Caustic Soda	>480
Chlorobenzene	38
Crude Oil	>480
Dimethyl Sulfate	>480
Ethanol	>480
Fuel Oil LS	>480
Hydrofluoric Acid 48%	>480
Hydrogen Peroxide	>480
Jet Fuel A	>480
Methanol	>480
Methyl Acetate	330
Methyl Bromide	59
N,N-Dimethylformamide	77
Nitric Acid	>480
Nitrobenzene	97
Phenol @43 C	287
Potassium Hydroxide	>480
Sodium Hydroxide	>480
Sodium Hypochlorite	>480
Sulfuric Acid	>480
Trifluoroacetic Acid	>480

* Industrial chemical testing was conducted in accordance with ASTM F 739 with normalized breakthrough times reported in minutes. For detailed technical data and physical properties see page 30 or visit kappler.com.

Zytron® 200



Shown above are typical garment types for this fabric. View standard styles at kappler.com and see page 29 for custom options.

Hooded coverall styles feature LongNeck™ extended neck design.

Heat-sealed/taped garments (shown) come with double storm flaps, and bound seam garments come with a single storm flap.

Tingley HazProof® boots are available from Kappler as an authorized distributor.



ChemScan® labels – quick, accurate and only from Kappler. Scan the label with your phone's QR reader for a complete list of chemicals tested against your garment's protective fabric.

Zytron 300

From Petro-Hazards To Warfare Agents, Zytron 300 Is A True Performance Fabric.

- Ideal for demanding applications with potential for chemical splash.
- Increased physical strength and broad chemical holdout take the protection level up a serious notch.
- Available in seven NFPA certified styles.
- Excellent for petrochemical operations including chemical handling and maintenance work – a favorite for military operations.
- A real workhorse of the Zytron family, available in a wide range of garment types and styles.



Zytron 300

ASTM F1001 Chemical Test Battery*

Chemical	Minutes
Acetone	>480
Acetonitrile	87
Carbon Disulfide	>480
Dichloromethane	70
Diethylamine	>480
Dimethylformamide	>480
Ethyl Acetate	>480
n - Hexane	>480
Methyl Alcohol	55
Nitrobenzene	>480
Sodium Hydroxide	>480
Sulfuric Acid	>480
Tetrachloroethylene	>480
Tetrahydrofuran	>480
Toluene	>480
Gases	
Ammonia Gas	39
1,3 Butadiene Gas	>480
Chlorine Gas	>480
Ethylene Oxide Gas	81
Hydrogen Chloride Gas	>480
Methyl Chloride Gas	>480

Chemical Warfare Agent Data**

Chemical Agent	Minutes	Criteria
Bis (2-chloroethyl) sulfide (Mustard:HD)	>480	4.0 ug/cm2
Isopropyl methylfluorophosphonate (Sarin:GB)	>480	1.25 ug/cm2
Chlorovinyl arsinedichloride (Lewisite:L)	>240	4.0 ug/cm2
O-ethyl S-(2-diisopropylaminoethyl) methylphosphonothiolate (Nerve:VX)	>480	1.25 ug/cm2

* Industrial chemical testing was conducted in accordance with ASTM F 739 with normalized breakthrough times reported in minutes. **Chemical Warfare Agent testing was conducted in accordance with MIL-STD-282 and/or NFPA 1994-2001 with breakthrough times reported based on total cumulative permeation. For detailed technical data and physical properties see page 30 or visit kappler.com.

Zytron® 300



Shown above are typical garment types for this fabric. View standard styles at kappler.com and see page 29 for custom options.

Large visor system on encapsulating suits for better field of vision.

Attached gloves are available on any heat sealed/taped seam garment.

Rear entry style shown provides protection in front-splash scenarios.

Attached sock booties with splash guards are standard.



Zytron 400

A Real Tough Guy With Great Physical Properties, Plus Broad Chemical Holdout.

- ASTM F1001 chemical holdout performance similar to Zytron 500 at an economical price.
- Excellent physical properties give Zytron 400 an advantage in garment strength.
- Styles include a variety of coveralls plus total encapsulating suits and hood/jacket/trouser combos.
- Applications: Chemical handling, petrochemical operations, hazmat response and clean-up.



Zytron 400

ASTM F1001 Chemical Test Battery*

Chemical	Minutes
Acetone	>480
Acetonitrile	>480
Carbon Disulfide	>480
Dichloromethane	88
Diethylamine	>480
Dimethylformamide	>480
Ethyl Acetate	>480
n - Hexane	>480
Methyl Alcohol	>480
Nitrobenzene	>480
Sodium Hydroxide	>480
Sulfuric Acid	>480
Tetrachloroethylene	>480
Tetrahydrofuran	>480
Toluene	>480
Gases	
Ammonia Gas	NT
1,3 Butadiene Gas	NT
Chlorine Gas	NT
Ethylene Oxide Gas	305
Hydrogen Chloride Gas	NT
Methyl Chloride Gas	NT

* Industrial chemical testing was conducted in accordance with ASTM F 739 with normalized breakthrough times reported in minutes. For detailed technical data and physical properties see page 30 or visit kappler.com.



ChemScan® labels – quick, accurate and only from Kappler.

Scan the label with your phone's QR reader for a complete list of chemicals tested against your garment's protective fabric.

Zytron® 400



Shown above are typical garment types for this fabric. View standard styles at kappler.com and see page 29 for custom options.



Tough fabric with excellent physical properties for demanding work applications.

Attached gloves are an available custom option.

Double storm flaps include hook and loop fasteners.

Attached sock booties with splash guards available on both coverall and encapsulating suit styles.

Available in
Orange or Charcoal

Zytron 500

Top Level Protection For Demanding Hazmat Response.

- Greater than 8-hour holdout against hundreds of chemicals, with proven holdout against Chemical Warfare Agents (CWA).
- NFPA 1994 Class 2 - 2012 Edition style available.
- Many features and options in a wide variety of encapsulating suits and coverall styles.
- Available in hi-viz orange and charcoal gray.
- Applications: Hazmat response, chemical handling, refueling operations, petrochemical operations, hazardous material clean-up and remediation, CWA incineration, remediation and disposal.



Zytron® 500

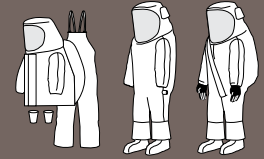

Shown above are typical garment types for this fabric. View standard styles at kappler.com and see page 29 for custom options.

Zytron 500 ASTM F1001 Chemical Test Battery*

Chemical	Minutes
Acetone	>480
Acetonitrile	>480
Carbon Disulfide	>480
Dichloromethane	>480
Diethylamine	>480
Dimethylformamide	>480
Ethyl Acetate	>480
n - Hexane	>480
Methyl Alcohol	>480
Nitrobenzene	>480
Sodium Hydroxide	>480
Sulfuric Acid	>480
Tetrachloroethylene	>480
Tetrahydrofuran	>480
Toluene	>480
Gases	
Ammonia Gas	>480
1,3 Butadiene Gas	>480
Chlorine Gas	>480
Ethylene Oxide Gas	>480
Hydrogen Chloride Gas	>480
Methyl Chloride Gas	>480

Chemical Warfare Agent Data**

Chemical Agent	Minutes	Criteria
Bis (2-chloroethyl) sulfide (Mustard:HD)	>480	4.0 ug/cm2
Isopropyl methylfluorophosphonate (Sarin:GB)	>480	1.25 ug/cm2
Chlorovinyl arsinedichloride (Lewsite:L)	>480	4.0 ug/cm2
O-ethyl S-(2-diisopropylaminoethyl) methylphosphonothiolate (Nerve:VX)	>480	1.25 ug/cm2

* Industrial chemical testing was conducted in accordance with ASTM F 739 with normalized breakthrough times reported in minutes. **Chemical Warfare Agent testing was conducted in accordance with MIL-STD-282 and/or NFPA 1994-2001 with breakthrough times reported based on total cumulative permeation. For detailed technical data and physical properties see page 30 or visit kappler.com.



New Expanded-View AntiFog Visor System is standard on all gas-tight suits.

All Hazmat styles include 2N1® Glove System which eliminates the problem of inner glove inversion.

HazMat styles include seams that are sewn then double heat sealed/taped.

Softer, pliable fabric enhances comfort for extended wear applications.

Frontline 300

Splash-And-Flash Protection For Petrochemical Environments.

- Three-way protection for chemical, flash-fire and radiant heat.
- Ideal for petrochemical line break operations – developed with input from petrochemical safety officers.
- Proven with demanding Pyroman Thermal Manikin testing.
- Multi-use, single-exposure garment provides economical alternative to expensive reusable FR apparel.
- Coverall and ensemble styles offer flexibility for a wide variety of work situations.
- Applications: Line maintenance, tank cleaning, refueling situations, clandestine lab response.



Frontline 300

ASTM F1001 Chemical Test Battery*

Chemical	Minutes
Acetone	>480
Acetonitrile	>480
Carbon Disulfide	>480
Dichloromethane	10
Diethylamine	>480
Dimethylformamide	>480
Ethyl Acetate	>480
n - Hexane	>480
Methyl Alcohol	>480
Nitrobenzene	>480
Sodium Hydroxide	>480
Sulfuric Acid	>480
Tetrachloroethylene	>480
Tetrahydrofuran	>480
Toluene	>480
Gases	
Ammonia Gas	>480
1,3 Butadiene Gas	>480
Chlorine Gas	>480
Ethylene Oxide Gas	>480
Other Chemicals Tested	
Benzene	>480
Diesel Fuel	>480
Diethylethanolamine	>480
Gasoline	>480
Hydrofluoric acid (48%)	>480
Kerosene	>480
Methanol	>480

* Industrial chemical testing was conducted in accordance with ASTM F 739 with normalized breakthrough times reported in minutes. For detailed technical data and physical properties see page 30 or visit kappler.com.

Frontline® 300



Shown above are typical garment types for this fabric. View standard styles at kappler.com and see page 29 for custom options.



Coverall styles feature special hood design for better fit against respirator.

Frontline 300 offers true "splash-and-flash" protection, plus excellent radiant heat protection.

Reinforced knee area for added confidence and work flexibility.

Frontline garments are designed for chemical flash-fire protection FOR ESCAPE ONLY in the event of a chemical flash fire.

ChemScan® labels – quick, accurate and only from Kappler.
Scan the label with your phone's QR reader for a complete list of chemicals tested against your garment's protective fabric.

Frontline 500

NFPA 1991 Certified Apparel For Chemical Flash-Fire Protection.

- Single suit provides three-way protection – chemical, flash-fire and radiant heat protection.
- Single garment eliminates need for two-suit NFPA 1991 configuration.
- Provides excellent “survivability” performance – 0% body burn in Pyroman Thermal Manikin testing.
- NFPA-certified multi-use, single-exposure garment provides economical alternative to expensive FR reusables.
- Applications: Hazmat response and chemical handling with potential for chemical flash-fire.



Frontline® 500

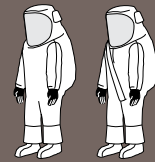

Shown above are typical garment types for this fabric. View standard styles at kappler.com and see page 29 for custom options.

Frontline 500 ASTM F1001 Chemical Test Battery*

Chemical	Minutes
Acetone	>480
Acetonitrile	>480
Carbon Disulfide	>480
Dichloromethane	253
Diethylamine	>480
Dimethylformamide	>480
Ethyl Acetate	>480
n - Hexane	>480
Methyl Alcohol	>480
Nitrobenzene	>480
Sodium Hydroxide	>480
Sulfuric Acid	>480
Tetrachloroethylene	>480
Tetrahydrofuran	>480
Toluene	>480
Gases	
Ammonia Gas	>480
1,3 Butadiene Gas	>480
Chlorine Gas	>480
Ethylene Oxide Gas	>480
Hydrogen Chloride Gas	>480
Methyl Chloride Gas	>480

Chemical Warfare Agent Data**

Chemical Agent	Minutes	Criteria
Bis (2-chloroethyl) sulfide (Mustard:HD)	>480	4.0 ug/cm2
Isopropyl methylfluorophosphonate (Sarin:GB)	>480	1.25 ug/cm2
Chlorovinyl arsinedichloride (Lewisite:L)	>240	4.0 ug/cm2
O-ethyl S-(2-diisopropylaminoethyl) methylphosphonothiolate (Nerve:VX)	>480	1.25 ug/cm2

* Industrial chemical testing was conducted in accordance with ASTM F 739 with normalized breakthrough times reported in minutes. **Chemical Warfare Agent testing was conducted in accordance with MIL-STD-282 and/or NFPA 1994-2001 with breakthrough times reported based on total cumulative permeation. For detailed technical data and physical properties see page 30 or visit kappler.com.



New Expanded-View AntiFog Visor System is standard on all gas-tight suits.

Removable knitted Kevlar overglove, plus field-replaceable 2N1® Glove System which eliminates the problem of inner glove inversion.

Highly flexible 48" gas-tight AquaSeal® zipper facilitates easier donning and doffing.

Frontline garments are designed for chemical flash-fire protection FOR ESCAPE ONLY in the event of a chemical flash fire.

Accessories And Specialty Products



ChemTape®

ChemTape is Kappler's patented chemical-resistant tape designed specifically for protective apparel. Provides added assurance for taping around gloves, boots, respirators and storm flaps, plus shelter-in-place applications. Rolls are 2" X 60 yd (48 mm wide and 55 meters long); 24 rolls per case. Style 99402 YW.

ChemTape® Responder ID Kit

Large, easy-to-read identification numbers enhance safety where worker identities are obscured. Self-adhesive, easy to apply, complete set includes numbers 0-9. 24 sets per case. Style 99415.



ChemTape

ASTM F1001 Chemical Test Battery*

Chemical	Minutes
Acetone	>480
Acetonitrile	>480
Carbon Disulfide	>480
Dichloromethane	>480
Diethylamine	160
Dimethylformamide	>480
Ethyl Acetate	>480
n - Hexane	>480
Methyl Alcohol	>480
Nitrobenzene	>480
Sodium Hydroxide	>480
Sulfuric Acid	>480
Tetrachloroethylene	>480
Tetrahydrofuran	>480
Toluene	>480

Chemical Warfare Agent Data**

Chemical Agent	Minutes	Criteria
Bis (2-chloroethyl) sulfide (Mustard:HD)	>480	4.0 ug/cm2
Isopropyl methylfluorophosphonate (Sarin:GB)	>480	1.25 ug/cm2
Chlorovinyl arsinedichloride (Lewisite:L)	NT	NT
O-ethyl S-(2-diisopropylaminoethyl) methylphosphonothiolate (Nerve:VX)	>480	1.25 ug/cm2

* Industrial chemical testing was conducted in accordance with ASTM F 739 with normalized breakthrough times reported in minutes. **Chemical Warfare Agent testing was conducted in accordance with MIL-STD-282 and/or NFPA 1994-2001 with breakthrough times reported based on total cumulative permeation.

Accessory and specialty products continue through page 28. For a complete list of Kappler accessories or additional details call customer service at 1.800.600.4019.

Kappler's Digital Pressure Test Kit Is Flexible, Easy To Use And Extremely Accurate.

Kappler's automated Digital Pressure Test Kit improves the efficiency and accuracy of gas-tight garment tests for both ASTM and CE methods. Our unique design features a digital readout for more accurate testing, while a large LCD touchscreen allows easy test criteria selection and data input. All fittings and hoses are included – the user simply provides a Grade D air supply with a 1/4 inch NPT fitting. Press START and the test is performed automatically, allowing the user to handle other duties while the test is in process. For easy and accurate record-keeping, test data can be copied to the provided USB stick via the built-in USB port. Style AKMOC.

A video of the test procedure and data formatting program can be found online at kappler.com/resources under "Training Videos."



USB port allows easy connection to a data storage device.

Large, easy-to-read touchscreen for selecting test criteria and data input.

2N1® Glove System Eliminates Inner Glove Inversion.

Kappler's 2N1® Glove System – a true innovation that eliminates the problem of inner glove inversion when the user removes a hand from the double-glove configuration common to gas-tight garments. This allows the user to easily remove or reinsert the hands into the glove without the annoying inversion. This is especially helpful when a user needs to free the hands inside the suit to adjust the respirator face piece, or access communication system or other equipment. The 2N1 Glove System also provides improved comfort and manual dexterity with a unique glove configuration. Contact Customer Service for style options.

The 2N1 Glove System is available on Kappler Zytron® 500 Hazmat styles and NFPA Certified styles in both Zytron® 300, 500 and Frontline® 500 fabrics.



Unique installation technique using rigid glove ring makes it easier to insert or withdraw hands.

Unique configuration also provides improved comfort and dexterity.

Accessories And Specialty Products

Zytron® 300 Half C Jacket

Kappler's Zytron 300 Half C Jacket is ideal for supplied-air work applications. The flat back design includes hood with PVC faceshield, double storm flaps with hook and loop fasteners and attached CP Cuff Option for easy glove taping. Loops for air system attached inside the hood. Style Z3H763 (Z3H763-30 includes tubes and Nupro valve), 6 garments per case.



Male Glove Insert Cones

Kappler's insert cones interface glove to suit and provide smooth taping surface. 1 pair per case, style AG0AR.



CP Cuff Option For Any Suit

Taping gloves with ChemTape® has become standard procedure for good protection. Our CP Cuff Option, available on any Kappler taped seam chemical garment, makes the job faster, easier and more effective. Eliminate chemical burns on hands and wrists – ask Customer Service about adding the CP Cuff Option to your next apparel order.



Attached CP Cuff Option makes taping fast and easy.

Cooling Vest

The Kappler Cooling Vest with patented Phase Change Material is lightweight and provides hours of cooling. Available in two cooling-capacity sizes, in mesh or FR Cotton. Contact Customer Service for style numbers.



For a complete list of Kappler accessories or additional details call customer service at 1.800.600.4019.

Decon Shower

Kappler's patented Decontamination Shower is made with Zytron 500 fabric to ensure hazardous material run-off is safely contained. The removable spray wand with adjustable shut-off valve and ergo-grip handle allow better water control during decon. Simple design and snap-lock components mean easy setup and take-down. Catch Basin w/ frame and shower wand, Style Z5HD0. Shower curtain and frame, Style Z5HD1.





FLEX 24-7

TOP OF ITS CLASS IN COMFORT AND PROTECTION

SHELBY KOALA GOLD SPLIT COWHIDE

Snag resistant 3M Scotchlite® reflective nail guards, CROSSTECH® Glove Inserts and SHELBY® #1 Glove In Fire® labels



SHELBY ENGINEERED

3M Scotchlite® Reflective Tips

CROSSTECH® Film Technology Insert

Hi-Tech KEVLAR® Knit / Nomex® Airlocking Thermal Barrier

Simplex® KEVLAR® Conforms To Fit Any Size Hand With Better Wearing Comfort

FINGERTIP ATTACHMENT SYSTEM -

Relays fantastic fingertip tactility & control. All layers & your fingertips lay snugly adjacent to each other! Patent Pending.

THERMAL PROTECTION ZONES -

A lightweight protection system that relays 50% more protection than other barrier / thermal liner layups of equal or greater thickness. This innovative system CONTINUALLY protects the hands at a high level! Patent Pending

NEW - DIRECT GRIP™ LINING

Direct Grip™ palm lining provides a strong athletic grip. This lining grips the hand vs the hand trying to grip the lining.

This is the only knit back NFPA 1971, 2013 Edition certified glove on the market with 3 layers of Kevlar® protection! Once again, Shelby is "Leading the field" in firefighter hand protection and it's made in the USA!

THIS STRUCTURAL FIRE FIGHTING PROTECTIVE GLOVE MEETS THE GLOVE REQUIREMENTS OF NFPA 1971, 2013 EDITION

BACK OF HAND PROTECTION

1. SIMPLEX® KEVLAR
2. HI-TECH KEVLAR / NOMEK KNIT
3. THERMAL PROTECTION ZONE
4. CROSSTECH® Film Technology
5. KEVLAR / TECH-FLEECE

SOMETIMES IT'S WHAT YOU CAN'T SEE THAT MATTERS MOST!

THE INVISIBLES -

At Shelby, Protection comes first, second, third, fourth...

A Thermal Protection System that continually protects the hands at a higher level!



WE ARE MADE IN THE USA

SHELBY

YOUR SINGLE SOURCE®

- 3M SCOTCHLITE REFLECTIVE TIPS
- 100% KEVLAR® SIMPLEX®
- SHELBY'S WASH & WEAR KOALA® TAN LEATHER
- 8.5 OZ. INSULAR KEVLAR®/NOMEX AIR LOCKING SPACER

THIS STRUCTURAL FIRE FIGHTING PROTECTIVE GLOVE MEETS THE GLOVE REQUIREMENTS OF NFPA 1971, 2013 EDITION



5284
WRISTLET

5285



5 LAYER

Back of Hand Protection
CONTINUALLY Relaying Excellent
TPP & Radiant Heat Protection
Where it's Needed Most!



- SIMPLEX® KEVLAR
- HI-TECH KEVLAR KNIT
- THERMAL PROTECTION ZONE
- CROSSTECH® FILM TECHNOLOGY
- KEVLAR / TECH-FLEECE

STYLE: 5284 & 5285

TOP OF ITS CLASS IN COMFORT AND PROTECTION

DESIGNED FOR BETTER PERFORMANCE AND FIT!

Shelby took all the elements in a glove that affect performance and dexterity, and re-engineered them. Durable wash & wear Koala® tanned leather was chosen for the palm for soft, flexible abrasion resistance. The highly engineered Insular textile construction for the back of the hand, provides thermal and flame resistance with increased pliability for added range of hand and finger motion. The total combination results in a glove with the ultimate in protection and dexterity.

FEATURES & BENEFITS

- A highly engineered insular construction that offers both a thermal and flame barrier already made famous in the automotive racing industry
- Shelby's innovative wash & wear Koala® tan leather palm stays soft and supple even after repeated washing.



www.shelbyglove.com - Toll Free 800-888-3598

SHELBY®

FLEX-TUFF®

Model #5291 and #5292

Masters in First Responder Hand Protection

First Responder Feedback



- ✓ Better Grip (Less Fatigue)
Direct Grip Palm Lining
- ✓ Better Fit with G-Block®
Prevents Glove Creep
- ✓ Most Durable 3D Glove

Back of Hand & Fingers (Layers)

1. Koala Gold® & Black Split Cowhide
2. Thermal Protection Zones (TPZ)
3. Crosstech® Film Technology Barrier
4. Kevlar® Blended Fleece

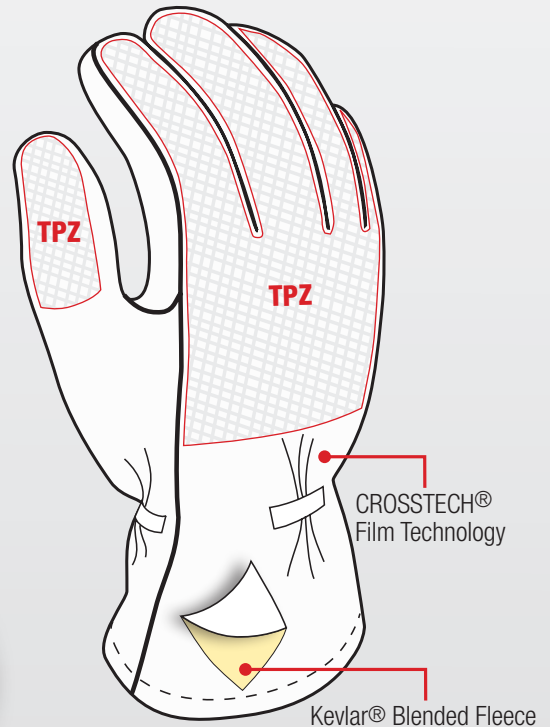

Model #5292



SHELBY SPECIALTY GLOVES • 800-888-3598 • FAX 901- 362-9127 • www.shelbyglove.com

HybridShield® is a registered trademark of NanoSonic, Inc., CROSSTECH® is a registered trademark of W.L.Gore and Associates, Nomex® and Kevlar® are registered trademarks of Dupont, SHELBY #1 Glove In Fire® and SHELBY FLEX-TUFF® are registered trademarks of Shelby Specialty Gloves

SHELBY®

FLEX-TUFF HS

Model #5293 and #5294

Masters in First Responder Hand Protection

First Responder Feedback



- ✓ Better Don and Doff (wet or Dry)
- ✓ Better Fit with G-Block® Prevents Glove Creep
- ✓ Better Flexibility

Back of Hand & Fingers (Layers)

1. Kevlar Simplex® Knit with HybridShield®
2. Thermal Protection Zones (TPZ)
3. Crosstech® Film Technology Barrier
4. Kevlar® Blended Fleece

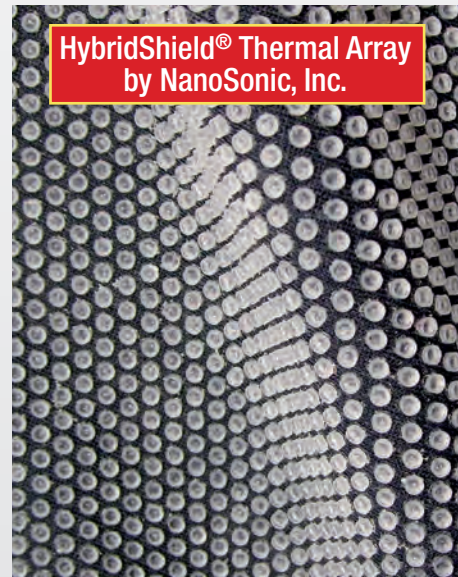

Military grade Materials for Structural Firefighters



Model #5294



SHELBY SPECIALTY GLOVES • 800-888-3598 • FAX 901- 362-9127 • www.shelbyglove.com

HybridShield® is a registered trademark of NanoSonic, Inc., CROSSTECH® is a registered trademark of W.L.Gore and Associates, Nomex® and Kevlar® are registered trademarks of Dupont, SHELBY #1 Glove In Fire® and SHELBY FLEX-TUFF® are registered trademarks of Shelby Specialty Gloves



#2533

Rescue Glove

Sizes: S, M, L, XL, J



Materials/Features

- Abrasion Resistant Brushed Pigskin
- Reinforced Keystone Thumb & Palm
- Lock-Stitch Sewn with Kevlar Thread
 - Elastic Snuggler at Wrist
 - Wash & Wear



SHELBY SPECIALTY GLOVES
 3035 Centre Oak Way
 Suite 102
 Germantown, TN 38138 USA
 901-360-8928 800-888-3598
 FAX 901-362-9127
 www.shelbyglove.com

SHELBY® RESCUE GLOVES

GUARANTEED TOUGH

SHELBY SPECIALTY GLOVES



SHELBY®

RESCUE GLOVES GUARANTEED TOUGH



#2500

Xtrication® Rescue Glove

Sizes: S, M, L, XL, J

Materials / Features

- Kevlar Reinforced Palm & Fingers
- Injection Molded TPR Padding Covering Back of Hand and Knuckles
- Cotton Terry Braw Wipe and Lining
- Reinforced Rubber Pull with Carabineer Loop
- Custom Finger-Back Rubber Guards
- Reflective Finger tips

Fit / Comfort

- Pre-Curved Glove with Two-Way Stretch
- Air Flow Cordura Back
- Soft Cotton Terry Lining with "Snuggler" and Taslon Debris Blocker

WASH & WEAR



#2511

Xtrication® With Barrier

Sizes: S, M, L, XL, J

Materials / Features

- Hipora Waterproof Barrier
- Breathable Insulation
- Kevlar Reinforced Palm & Finger Tips
- Armor-Dillo Knuckle Protection
- Cotton Terry Braw Wipe
- Reinforced Rubber Pull with Carabineer Loop
- Custom Finger-Back Rubber Guards
- Reflective Finger Tips and Trim

Fit / Comfort

- Pre-Curved Glove with Two-Way Stretch
- Air Flow Cordura Back
- Interior Fleece Lining and "Snuggler" with Taslon Debris Blocker

#2518

Rope Rescue Glove

Sizes: S, M, L, XL, J

Materials / Features

- Premium Grade Goatskin Leather
- Cotton Terry Braw Wipe
- Reinforced Rubber Pull with Hidden Cord Carabineer Loop
- Neoprene Cuff with Hook & Loop Closure
- Kevlar Reinforced Stitching

Fit / Comfort

- Pre-Curved Glove. Beveled Fingers with Wrap Around Sidewalls & Tips
- Two-Way Stretch & Air Flow Back with Custom Impact Protection

WASH & WEAR



#2520

Xtrication® Rescue Glove

Sizes: S, M, L, XL, J

Materials / Features

- Hi-Vis Chartreus Color
- Synthetic Mesh Material on Back
- Injection Molded TPR Padding Covering Back of Hand and Knuckles
- Grain Goat Leather Palm with Dual Stitched Synthetic Sure Grip Palm and Finger Pads
- Adjustable Hook and Loop on Cushioned Wrist Band with Carabineer Loop and ID Tag

Fit / Comfort

- Pre-curved Glove with Two-Way Stretch
- Synthetic Hand Soft Lining
- Cotton Terry Braw Wipe
- Alycore Inside Palm, Providing Improved Cut & Puncture Resistance



#2517

Rescue Work Glove

Sizes: S, M, L, XL, J

Materials / Features

- Seamless Knit
- Over the Fingertip Protection
- Super Tacky Non Slip Latex Palm
- Rubber Reinforced Hook & Loop Closure

Fit / Comfort

- Pre-Curved Glove
- Soft Brushed lining
- Snug Fit



SHELBY

SHELBY SPECIALTY GLOVES WILDLAND RESCUE 5002 & 5002F



SPECIFICATIONS



Outer Shell: heavy 3 to 3.5 oz, popcorn and black color abrasion resistant, multi-directional fiber structure, brushed pigskin. Tanned hide does not contain PCP (pentachlorophenol), it is salts or esters.

Wristlet: 4" Nomex wristlet, 5002F No Wristlet

Pattern: Gunn cut, keystone double layer thumb crotch protection. 1/8" wide, double row stitching around inset thumb.

Sizes: XS, S, M, L, XL, J (Jumbo)

Design and Construction: THIS WILDLAND FIREFIGHTING PROTECTIVE WORK GLOVE MEETS THE REQUIREMENTS OF NFPA 1977, STANDARD ON PROTECTIVE CLOTHING AND EQUIPMENT FOR WILDLAND FIREFIGHTING, 2016 EDITION.

Made in USA





No Straps. No Lever. No Hassle.

SmartDock, by IMMI®, is the first and **only** hands-free SCBA holder for fire apparatus. Firefighters no longer have to waste precious time fumbling with a cord or lever. With SmartDock, they simply stand up, exit the apparatus, and get to the fire faster.

Offering single-motion SCBA insertion and hands-free release, SmartDock is the clear choice for fire departments across the country. In the event of a crash, the top claws clamp down for a secure hold, preventing the tank from becoming a projectile.

Engineered so one model fits nearly all SCBAs used in today's U.S. fire departments, SmartDock is low profile and easily and quickly retrofits to a wide variety of seats.

A European model is also available.

90° Valve

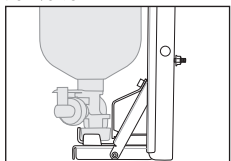

Inline Valve

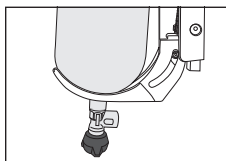



When seconds count.

When called into action, firefighters need to move quickly, and you shouldn't have to choose between sacrificing precious seconds to save others and your own safety. That's why more fire departments choose SmartDock, by IMMI, the first and only hands-free SCBA holder for fire apparatus. With no annoying straps or levers, SmartDock offers single-motion SCBA insertion and hands-free release when the firefighter stands up to exit the seat. In the event of a collision, the top claws clamp down for a secure hold, preventing the cylinder from becoming a projectile.

Availability

SmartDock is available for all major OEMs. Contact your dealer representative for more information or to buy SmartDock.



IMMI reminds you to always buckle up.

When seconds count, count on SmartDock.

How it Works:

1. Simply set the SCBA into the SmartDock base and gently push it into the upper claw.
2. Check to make sure the SmartDock SCBA holder is properly adjusted. The knob on top of the SmartDock allows for easy adjustment.
3. SmartDock holds the tank securely during transit and locks it in place in the event of a crash.
4. SmartDock releases the tank with no levers or straps. Once the SCBA is strapped on, simply bend at the waist and stand up to release the tank from the upper claw.



IMMI
imminet.com

Steve Ward
sward@imminet.com

18881 IMMI Way
Westfield, IN 46074
317.896.9531





FIRE LADDERS

Aluminum & Fiberglass

"Use a Good Ladder or Stay on the Ground"

Toll Free: 877-386-5377 (DUOLDERS)

www.duosafety.com



DUO-SAFETY LADDER CORPORATION



Solid Beam Aluminum Ladders

These incorporate Duo-Safety's exclusive tongue and groove arrangement. This outstanding construction design holds the sections firmly and rigidly, without brackets, hooks or obstructions of any kind. These compact ladders require a minimum of banking space - and have the extra advantage of being especially stable and rigid.

Series 1000-A

2 3/4" Channel Rail
750 lb Duty Rated

SPECIFICATIONS

SERIES 1000-A 2-SECTION

Size	Closed Length	Width	Banking Thickness	Weight
10'	7' 2.25"	18.5"	4.56"	29 lbs
12'	8' 2.25"	18.5"	4.56"	32 lbs
14'	9' 2.25"	18.5"	4.56"	34 lbs
16'*	9' 11.5"	18.5"	4.56"	40 lbs

All dimensions listed are N.F.P.A. Design Verification Standards. Variations occur in each product of approximately +/- .125" due to the type of rivets, nuts, bolts etc. used. If you require precise dimensions, please call our office and request a copy of our current field dimension sheets.

Weight listed is actual weight of product only. For shipping purposes, please call our office for packaged weight before obtaining freight estimates.

Prong Feet as Standard
Rubber safety shoes optional for hard surface use

*Only the 16' length has a pulley and 3/8" manila rope installed
All other lengths are raised manually

DUO-SAFETY LADDER CORPORATION 513 W 9th Avenue PO Box 497 Oshkosh WI 54903-0497

Toll Free: 877-386-5377

Fax: 920-231-2460

mail@duosafety.com

www.duosafety.com



DUO-SAFETY LADDER CORPORATION

Solid Beam Aluminum Ladders

These incorporate Duo-Safety's exclusive tongue and groove arrangement. This outstanding construction design holds the sections firmly and rigidly, without brackets, hooks or obstructions of any kind. These compact ladders require a minimum of banking space - and have the extra advantage of being especially stable and rigid.

Series 900-A

Series 925-A

3 1/4" Channel Rail
750 lb Duty Rated

SPECIFICATIONS

SERIES 900-A 2-SECTION

Size	Closed Length	Width	Banking Thickness	Weight
20'	12' 2.75"	21.75"	5.375"	60 lbs
24'	14' 2.75"	21.75"	5.375"	72 lbs

SERIES 925-A 3-SECTION

Size	Closed Length	Width	Banking Thickness	Weight
22'	10' 8.75"	24"	7.625"	82 lbs
26'	11' 8.75"	24"	7.625"	92 lbs

All dimensions listed are N.F.P.A. Design Verification Standards. Variations occur in each product of approximately +/- .125" due to the type of rivets, nuts, bolts etc. used. If you require precise dimensions, please call our office and request a copy of our current field dimension sheets.

Weight listed is actual weight of product only. For shipping purposes, please call our office for packaged weight before obtaining freight estimates.



Model 900A



Model 925A

Prong Feet as Standard
Rubber safety shoes optional for hard surface use

DUO-SAFETY LADDER CORPORATION 513 W 9th Avenue PO Box 497 Oshkosh WI 54903-0497

Toll Free: 877-386-5377

Fax: 920-231-2460

mail@duosafety.com

www.duosafety.com



DUO-SAFETY LADDER CORPORATION

Solid Beam Aluminum Ladders

These incorporate Duo-Safety's exclusive tongue and groove arrangement. This outstanding construction design holds the sections firmly and rigidly, without brackets, hooks or obstructions of any kind. These compact ladders require a minimum of banking space - and have the extra advantage of being especially stable and rigid.

Series 1200-A

Series 1225-A

3 3/4" Channel Rail
750 lb Duty Rated

SPECIFICATIONS

SERIES 1200-A 2-SECTION

Size	Closed Length	Width	Banking Thickness	Weight
28'	16' 3.25"	24"	6.5"	87 lbs
30'	18' 3.25"	24"	6.5"	107 lbs
35'	20' 3.25"	24"	6.5"	122 lbs

SERIES 1225-A 3-SECTION

Size	Closed Length	Width	Banking Thickness	Weight
28'	12' 11"	24"	9.125"	107 lbs
30'	13' 3"	24"	9.125"	108 lbs
35'	15' 3"	24"	9.125"	129 lbs

All dimensions listed are N.F.P.A. Design Verification Standards. Variations occur in each product of approximately +/- .125" due to the type of rivets, nuts, bolts etc. used. If you require precise dimensions, please call our office and request a copy of our current field dimension sheets.

Weight listed is actual weight of product only. For shipping purposes, please call our office for packaged weight before obtaining freight estimates.

Prong Feet as Standard

Rubber safety shoes optional for hard surface use



Model 1225A



Model 1200A

DUO-SAFETY LADDER CORPORATION 513 W 9th Avenue PO Box 497 Oshkosh WI 54903-0497

Toll Free: 877-386-5377

Fax: 920-231-2460

mail@duosafety.com

www.duosafety.com



DUO-SAFETY LADDER CORPORATION

Solid Beam Aluminum Ladders

Originally produced for the Forestry Departments for use on their brush pumps. This ladder was designed for a maximum closed length to fit in a restricted space. Due to the compact design, this ladder does not have a cable pulley to help extend the fly section. In order to extend the ladder, you must first extend the fly section by hand and use the rope and pulley to fully extend the ladder.

Series 912

3 1/4" Channel Rail
750 lb Duty Rated



SPECIFICATIONS

SERIES 912-86 3-SECTION

Size	Closed Length	Width	Banking Thickness	Weight
16'	86"	24"	8.125"	65 lbs

SERIES 912-100 3-SECTION

Size	Closed Length	Width	Banking Thickness	Weight
20'	100"	24"	8.125"	80 lbs

All dimensions listed are N.F.P.A. Design Verification Standards. Variations occur in each product of approximately +/- .125" due to the type of rivets, nuts, bolts etc. used. If you require precise dimensions, please call our office and request a copy of our current field dimension sheets.

Note: Due to compact size - you must manually extend fly/top section by hand and use the rope & pulley to fully extend the ladder.

Weight listed is actual weight of product only. For shipping purposes, please call our office for packaged weight before obtaining freight estimates.

Prong Feet as Standard
Rubber safety shoes optional for hard surface use

DUO-SAFETY LADDER CORPORATION 513 W 9th Avenue PO Box 497 Oshkosh WI 54903-0497

Toll Free: 877-386-5377

Fax: 920-231-2460

mail@duosafety.com

www.duosafety.com



DUO-SAFETY LADDER CORPORATION

Solid Beam Aluminum Ladders

These incorporate Duo-Safety's exclusive tongue and groove arrangement. This outstanding construction design holds the sections firmly and rigidly, without brackets, hooks or obstructions of any kind. These compact ladders require a minimum of banking space - and have the extra advantage of being especially stable and rigid.

Series 1500-A

Series 1525-A

5" Channel Rail
750 lb Duty Rated

SPECIFICATIONS

SERIES 1500-A 2-SECTION WITH POLES

Size	Closed Length	Width over Poles	Banking Thickness	Weight
40'	23' 4"	*26.5"	7.4"	213 lbs
45'	26' 4"	26.5"	7.4"	242 lbs

SERIES 1525-A 3-SECTION WITH POLES

Size	Closed Length	Width over Poles	Banking Thickness	Weight
40'	16' 10"	*26.5"	9.8"	215 lbs
45'	19'	26.5"	9.8"	240 lbs

All dimensions listed are N.F.P.A. Design Verification Standards. Variations occur in each product of approximately +/- .125" due to the type of rivets, nuts, bolts etc. used. If you require precise dimensions, please call our office and request a copy of our current field dimension sheets.

Weight listed is actual weight of product only. For shipping purposes, please call our office for packaged weight before obtaining freight estimates.

*Staypoles are optional on 40 ft length.

Base width is 24" standard plus 2.5" to go over poles.

Weight without poles deduct approx. 35 lbs each.

MFG Note: We do recommend Staypoles for 40' ladders even though NFPA has listed as optional

Prong Feet as Standard

Rubber safety shoes optional for hard surface use

All Extension ladders 40' and over are equipped with 1/2" manila rope as standard

DUO-SAFETY LADDER CORPORATION 513 W 9th Avenue PO Box 497 Oshkosh WI 54903-0497

Toll Free: 877-386-5377

Fax: 920-231-2460

mail@duosafety.com

www.duosafety.com



DUO-SAFETY LADDER CORPORATION

Aluminum Roof Ladders

Famous Duo-Safety Rail Construction provides the advantage of extra strength without cumbersome weight. Ideal for pumper use - these outstanding ladders have been proven and approved for many years by fire companies everywhere. Installed with standard 3/4" hooks or heavy duty 7/8" hooks for an additional fee.

Series 775-A

Series 875-A

Series 1275-A

Channel Rail Construction
750 lb Duty Rated

SPECIFICATIONS

SERIES 775-A ROOF

Size	Length	Width	Rail Size	Weight
10'	10' 2.25"	19"	2.75"	22 lbs
12'	12' 2.25"	19"	2.75"	24 lbs
14'	14' 2.25"	19"	2.75"	28 lbs

SERIES 875-A ROOF

Size	Length	Width	Rail Size	Weight
16'	16' 2.5"	19"	3.25"	39 lbs
18'	18' 2.5"	19"	3.25"	44 lbs
20'	20' 2.5"	19"	3.25"	48 lbs

SERIES 1275-A ROOF

Size	Length	Width	Rail Size	Weight
25'	25' 3"	19"	3.75"	64 lbs
30'	30' 3"	19"	3.75"	72 lbs

All dimensions listed are N.F.P.A. Design Verification Standards. Variations occur in each product of approximately +/- .125" due to the type of rivets, nuts, bolts etc. used. If you require precise dimensions, please call our office and request a copy of our current field dimension sheets.

Weight listed is actual weight of product only. For shipping purposes, please call our office for packaged weight before obtaining freight estimates.

Prong Feet as Standard

Rubber safety shoes optional for hard surface use

DUO-SAFETY LADDER CORPORATION 513 W 9th Avenue PO Box 497 Oshkosh WI 54903-0497

Toll Free: 877-386-5377

Fax: 920-231-2460

mail@duosafety.com

www.duosafety.com



DUO-SAFETY LADDER CORPORATION

Aluminum Double End Roof Ladders

Famous Duo-Safety Rail Construction provides the advantage of extra strength without cumbersome weight. This ladder was designed for firefighters so that no matter what end of the ladder is on top at the roof peak, there are hooks available. Installed with standard 3/4" hooks or heavy duty 7/8" hooks for an additional fee.

Series 775-DR

Series 875-DR

Channel Rail Construction
750 lb Duty Rated

SPECIFICATIONS

SERIES 775-DR DOUBLE END ROOF

Size	Length	Width	Rail Size	Weight
10'	10' 1.625"	19"	2.75"	29 lbs
12'	12' 1.625"	19"	2.75"	33 lbs
14'	14' 1.625"	19"	2.75"	35 lbs

SERIES 875-DR DOUBLE END ROOF

Size	Length	Width	Rail Size	Weight
16'	16' 2.125"	19"	3.25"	49 lbs
18'	18' 2.125"	19"	3.25"	53 lbs
20'	20' 2.125"	19"	3.25"	56 lbs

All dimensions listed are N.F.P.A. Design Verification Standards. Variations occur in each product of approximately +/- .125" due to the type of rivets, nuts, bolts etc. used. If you require precise dimensions, please call our office and request a copy of our current field dimension sheets.

MFG Note: We do not recommend retro fitting older ladders for double hooks.

Weight listed is actual weight of product only. For shipping purposes, please call our office for packaged weight before obtaining freight estimates.

Prong Feet as Standard
Rubber safety shoes optional for hard surface use

DUO-SAFETY LADDER CORPORATION 513 W 9th Avenue PO Box 497 Oshkosh WI 54903-0497

Toll Free: 877-386-5377

Fax: 920-231-2460

mail@duosafety.com

www.duosafety.com



DUO-SAFETY LADDER CORPORATION

Folding Roof Ladders

Equipped with directional folding roof hooks, the Folding Roof Ladder was designed to save space when stored on your fire truck unit. This ladder easily folds for side mounting on a standard engine, yet opens and locks into a long roof ladder for use.

****Please note: this ladder is NOT designed for use as an A-frame style ladder, refer to our 35B or 300A models.**

Series 1275-FR

3 3/4" Channel Rail
750 lb Duty Rated



Shown in a slightly open/closing position to demonstrate how it folds up for storage. **NOT intended to be used in this manner.**

SPECIFICATIONS

SERIES 1275-FR

Lengths	Extended Length	Closed Length	Width	Banking Thickness	Weight
8' - 16'	16' 4.75"	8' 3"	*19"	7.625"	65 lbs
10' - 20'	20' 4.75"	10' 3"	*19"	7.625"	72 lbs
12' - 24'	24' 4.75"	12' 3"	*19"	7.625"	80 lbs
14' - 28'	28' 4.75"	14' 3"	*19"	7.625"	86 lbs
15' - 30'	30' 4.75"	15' 3"	*19"	7.625"	97 lbs

* Overall width including bolt heads on hinge brackets = 20.25"

All dimensions listed are N.F.P.A. Design Verification Standards. Variations occur in each product of approximately +/- .125" due to the type of rivets, nuts, bolts etc. used. If you require precise dimensions, please call our office and request a copy of our current field dimension sheets.

Weight listed is actual weight of product only. For shipping purposes, please call our office for packaged weight before obtaining freight estimates.

Prong Feet as Standard

Rubber safety shoes optional for hard surface use

DUO-SAFETY LADDER CORPORATION 513 W 9th Avenue PO Box 497 Oshkosh WI 54903-0497

Toll Free: 877-386-5377

Fax: 920-231-2460

mail@duosafety.com

www.duosafety.com



DUO-SAFETY LADDER CORPORATION

Aluminum Wall Ladders

Famous Duo-Safety Rail Construction provides the advantage of extra strength without cumbersome weight. Ideal for pumper use - these outstanding ladders have been proven and approved for many years by fire companies everywhere.

Series 750-A

Series 850-A

Series 1250-A

Channel Rail Construction
750 lb Duty Rated

SPECIFICATIONS

SERIES 750-A WALL

Size	Length	Width	Rail Size	Weight
8'	8' 2.25"	19"	2.75"	14 lbs
10'	10' 2.25"	19"	2.75"	17 lbs
12'	12' 2.25"	19"	2.75"	20 lbs
14'	14' 2.25"	19"	2.75"	25 lbs

SERIES 850-A WALL

Size	Length	Width	Rail Size	Weight
16'	16' 2.5"	19"	3.25"	35 lbs
18'	18' 2.5"	19"	3.25"	43 lbs
20'	20' 2.5"	19"	3.25"	45 lbs

SERIES 1250-A WALL

Size	Length	Width	Rail Size	Weight
25'	25' 3"	19"	3.75"	62 lbs
30'	30' 3"	19"	3.75"	70 lbs

All dimensions listed are N.F.P.A. Design Verification Standards. Variations occur in each product of approximately +/- .125" due to the type of rivets, nuts, bolts etc. used. If you require precise dimensions, please call our office and request a copy of our current field dimension sheets.

Weight listed is actual weight of product only. For shipping purposes, please call our office for packaged weight before obtaining freight estimates.

Prong Feet as Standard

Rubber safety shoes optional for hard surface use

DUO-SAFETY LADDER CORPORATION 513 W 9th Avenue PO Box 497 Oshkosh WI 54903-0497

Toll Free: 877-386-5377

Fax: 920-231-2460

mail@duosafety.com

www.duosafety.com



DUO-SAFETY LADDER CORPORATION

Aluminum Truss Fire Ladders

The 500-C Series ladders represent great strength and extraordinary safety. All this is incorporated into the tubular rail construction of this ladder. Available in all standard sizes - see specifications below.

Series 500-C

Series 525-C

750 lb Duty Rated

SPECIFICATIONS

SERIES 500-C 2-SECTION

Size	Closed Length	Width	Width Over Poles	Banking Thickness	Weight
14'	9' .75"	24"		7"	74 lbs
16'	10' .75"	24"		7"	75 lbs
18'	11' .75"	24"		7"	76 lbs
20'	12' .75"	24"		7"	78 lbs
24'	14' .625"	24"		7"	90 lbs
28'	16' .625"	24"		8"	112 lbs
30'	18' .75"	24"		8"	131 lbs
35'	20'	24"		8"	153 lbs
40'	23' .75"	24"	*26"	8"	210 lbs
45'	26' .75"	24"	26"	9"	255 lbs
50'	28' .75"	24"	26"	9"	279 lbs

SERIES 525-C 3-SECTION

Size	Closed Length	Width	Width Over Poles	Banking Thickness	Weight
28'	13' .75"	26"		10.25"	140 lbs
30'	14' .75"	26"		10.25"	164 lbs
35'	15' 4"	26"		10.25"	179 lbs
40'	17' 7.75"	26"	*28.5"	10.25"	245 lbs
45'	19' .75"	26"	28.5"	11.25"	265 lbs
50'	21' 2.75"	26"	28.5"	11.25"	297 lbs

All dimensions listed are N.F.P.A. Design Verification Standards. Variations occur in each product of approximately +/- .125" due to the type of rivets, nuts, bolts etc. used. If you require precise dimensions, please call our office and request a copy of our current field dimension sheets.

Weight listed is actual weight of product only.
For shipping purposes, please call our office for packaged weight before obtaining freight estimates.

*Staypoles are optional on 40 ft length
 Weight without poles deduct approx. 35 lbs each

All Extension ladders 40' and over are equipped with 1/2" manila rope as standard

Prong Feet as Standard
 Rubber safety shoes optional for hard surface use

DUO-SAFETY LADDER CORPORATION 513 W 9th Avenue PO Box 497 Oshkosh WI 54903-0497

Toll Free: 877-386-5377

Fax: 920-231-2460

mail@duosafety.com

www.duosafety.com



DUO-SAFETY LADDER CORPORATION

Aluminum Truss Fire Ladders

The tubular construction of Duo-Safety's 500-C Series incorporates the inherent strength of a rectangle, a channel and an "I" beam combined to provide the ultimate in strength and safety. Construction features include: double parallel fins; double set of truss plates; ribbed, extruded rungs, electrically welded to outside of truss plates; and aluminum rivets.

Series 575-C Roof

Series 550-C Wall

750 lb Duty Rated

SPECIFICATIONS

SERIES 575-C ROOF

Size	Length	Width	Rail Size	Weight
10'	10' .5"	19.75"	4.5"	39 lbs
12'	12' .5"	19.75"	4.5"	43 lbs
14'	14' .5"	19.75"	4.5"	50 lbs
16'	16' .5"	19.75"	4.5"	55 lbs
18'	18' .5"	19.75"	4.5"	57 lbs
20'	20' .5"	19.75"	4.5"	63 lbs
25'	25' .5"	19.75"	4.5"	80 lbs
30'	30' .5"	19.75"	5.5"	100 lbs

SERIES 550-C WALL

Size	Length	Width	Rail Size	Weight
10'	10' .5"	22.5"	4.5"	31 lbs
12'	12' .5"	22.5"	4.5"	37 lbs
14'	14' .5"	22.5"	4.5"	44 lbs
16'	16' .5"	22.5"	4.5"	48 lbs
18'	18' .5"	22.5"	4.5"	55 lbs
20'	20' .5"	22.5"	4.5"	59 lbs
22'	22' .5"	22.5"	4.5"	67 lbs
24'	24' .5"	22.5"	4.5"	74 lbs
25'	25' .5"	22.5"	4.5"	77 lbs
26'	26' .5"	22.5"	5.5"	81 lbs
28'	28' .5"	22.5"	5.5"	88 lbs
30'	30' .5"	22.5"	5.5"	96 lbs

All dimensions listed are N.F.P.A. Design Verification Standards. Variations occur in each product of approximately +/- .125" due to the type of rivets, nuts, bolts etc. used. If you require precise dimensions, please call our office and request a copy of our current field dimension sheets.

Weight listed is actual weight of product only. For shipping purposes, please call our office for packaged weight before obtaining freight estimates.



Model 575C



Model 550C

Prong Feet as Standard - Rubber safety shoes optional for hard surface use

DUO-SAFETY LADDER CORPORATION 513 W 9th Avenue PO Box 497 Oshkosh WI 54903-0497

Toll Free: 877-386-5377

Fax: 920-231-2460

mail@duosafety.com

www.duosafety.com



DUO-SAFETY LADDER CORPORATION

Aluminum Folding Ladders

The ultimate in handy, convenient and light weight, these ladders fold into a compact bundle for storing or carrying. In the open position, special locking devices keep the ladders absolutely rigid. Equipped with Duo-Safety Ladder shoes as an extra precaution.

Series 585-A

300 lb Duty Rated

SPECIFICATIONS

SERIES 585-A ALUMINUM

Size	Open Length	Closed Length	Open Width	Banking Thickness	Weight
8'	8' .375"	8' 9.75"	13.325"	*2.75"x4.52"	13 lbs
9'	9' 1.87"	10' .25"	13.325"	*2.75"x4.52"	15 lbs
10'	10' 1.87"	11' .25"	13.325"	*2.75"x4.52"	16 lbs
12'	12' .375"	12' 10.75"	13.325"	*2.75"x4.52"	20 lbs
14'	14' .375"	14' 10.75"	13.325"	*2.75"x4.52"	22 lbs

*Overall width includes shoes

All dimensions listed are N.F.P.A. Design Verification Standards. Variations occur in each product of approximately +/- .125" due to the type of rivets, nuts, bolts etc. used. If you require precise dimensions, please call our office and request a copy of our current field dimension sheets.

Weight listed is actual weight of product only. For shipping purposes, please call our office for packaged weight before obtaining freight estimates.

Safety Warnings

This ladder folds side to side (together) - caution should be used when placing your hands/fingers for closing and opening ladder.

If the lock assembly is bent or does not properly lock
DO NOT USE ladder as it is not safe to climb



DUO-SAFETY LADDER CORPORATION

Combination Jackknife "A" & Single Ladders

An unusually versatile ladder with countless uses for both indoor and outdoor work. This combination ladder serves as a rugged single ladder - or can be easily converted into a sturdy "A" type ladder with a double climbing side. Strong, heavy gauge steel locking device makes changeover easy and fast. Equipped with famous Duo-Safety Ladder shoes for extra safety.

Series 35-B

3 1/4" Channel Rail
750 lb Duty Rated



SPECIFICATIONS

SERIES 35-B ALUMIUM

Size	Closed Length	Height as (A) Type	Length as single	Width	Banking Thickness	Weight
4' - 8'	4' 1.875"	3' 10.62"	8' 1.75"	*19.75"	**8.37"	35 lbs
6' - 12'	6' 1.875"	5' 10.62"	12' 1.75"	*19.75"	**8.37"	40 lbs
7' - 14'	7' 1.875"	6' 10.62"	14' 1.75"	*19.75"	**8.37"	45 lbs
8' - 16'	8' 1.875"	7' 10.62"	16' 1.75"	*19.75"	**8.37"	50 lbs

*Overall width including safety shoes = 20.5"

** Banking height includes safety shoes tilted in open position

All dimensions listed are N.F.P.A. Design Verification Standards. Variations occur in each product of approximately +/- .125" due to the type of rivets, nuts, bolts etc. used. If you require precise dimensions, please call our office and request a copy of our current field dimension sheets.

Weight listed is actual weight of product only. For shipping purposes, please call our office for packaged weight before obtaining freight estimates.

DUO-SAFETY LADDER CORPORATION 513 W 9th Avenue PO Box 497 Oshkosh WI 54903-0497

Toll Free: 877-386-5377

Fax: 920-231-2460

mail@duosafety.com

www.duosafety.com



DUO-SAFETY LADDER CORPORATION

Combination Step and Extension Ladders

The 300 Series Combination Ladder is ideal for indoor fire fighting. In attics and other confined spaces, this sturdy, ruggedly constructed ladder can be quickly and easily changed from an 8' step to a 13' extension. Extra strong rails and rungs are typical of the heavy duty construction that means extra safety and service provided by this practical, versatile ladder.

Series 300-A

2 3/4" Channel Rail
750 lb Duty Rated



SPECIFICATIONS

SERIES 300-A ALUMINUM

Size	Closed Length	Height as Step Ladder	Length Extended	Width	Banking Thickness	Weight
6' - 9'	6' 2"	5' 6"	9'	*23.25"	**5.68"	34 lbs
8' - 13'	8' 2.25"	7' 6"	13'	*23.25"	**5.68"	42 lbs
10' - 15'	9' 10.875"	9' 6"	15'	*23.25"	**5.68"	47 lbs

*Overall width including bolt heads on hinge brackets = 23.75"

** Overall banking height including rivet heads and spreader bar = 6.43"

All dimensions listed are N.F.P.A. Design Verification Standards. Variations occur in each product of approximately +/- .125" due to the type of rivets, nuts, bolts etc. used. If you require precise dimensions, please call our office and request a copy of our current field dimension sheets.

Weight listed is actual weight of product only. For shipping purposes, please call our office for packaged weight before obtaining freight estimates.

Prong Feet as Standard
Rubber safety shoes optional for hard surface use

DUO-SAFETY LADDER CORPORATION 513 W 9th Avenue PO Box 497 Oshkosh WI 54903-0497

Toll Free: 877-386-5377

Fax: 920-231-2460

mail@duosafety.com

www.duosafety.com



DUO-SAFETY LADDER CORPORATION

“FRESNO” Aluminum Attic Extension Ladder

“Fresno” Series 701 Aluminum Attic Extension Ladders have become very popular in many sections of the country. Specifically designed for indoor use where space is limited, they are particularly ideal for entering attics through ceiling trap doors and similar close-quarter situations.

The “Fresno” Attic Extension Ladder features strong, light weight channel construction and is only 13” wide, making carrying easier on narrow stairways where longer, bulkier ladders cannot be used.

Series 701 Attic Extension Ladders are available in the stock sizes shown below and in special sizes on request.

Series 701

2 3/4” Channel Rail
750 lb Duty Rated



SPECIFICATIONS

SERIES 701 ALUMINUM

Size	Closed Length	Over Rail Width	Inside Top Section	Banking Thickness	Weight
10'	7' 2"	13"	7.75"	4.563"	27 lbs
12'	8' 2"	13"	7.75"	4.563"	30 lbs
14'	9' 2"	13"	7.75"	4.563"	32 lbs

All dimensions listed are N.F.P.A. Design Verification Standards. Variations occur in each product of approximately +/- .125" due to the type of rivets, nuts, bolts etc. used. If you require precise dimensions, please call our office and request a copy of our current field dimension sheets.

Weight listed is actual weight of product only. For shipping purposes, please call our office for packaged weight before obtaining freight estimates.

Prong Feet as Standard
Rubber safety shoes optional for hard surface use

DUO-SAFETY LADDER CORPORATION 513 W 9th Avenue PO Box 497 Oshkosh WI 54903-0497

Toll Free: 877-386-5377

Fax: 920-231-2460

mail@duosafety.com

www.duosafety.com

A background image showing various fire equipment: a red fire hose nozzle with a black handle and a red band with 'CPM 30 40' printed on it; a yellow fire hose with 'SUPPLY' printed on it; and a silver fire hydrant nozzle. The text 'AMERICA'S PREMIER FIRE EQUIPMENT MANUFACTURER' is overlaid in large, white, bold, sans-serif font with a black outline.

AMERICA'S PREMIER FIRE EQUIPMENT MANUFACTURER

Tel: 800-420-4673
Fax: 800-772-0255
KOCHEK.COM

2017
Catalog

HYDRANT CONVERTERS

SZMC Storz Standard Style

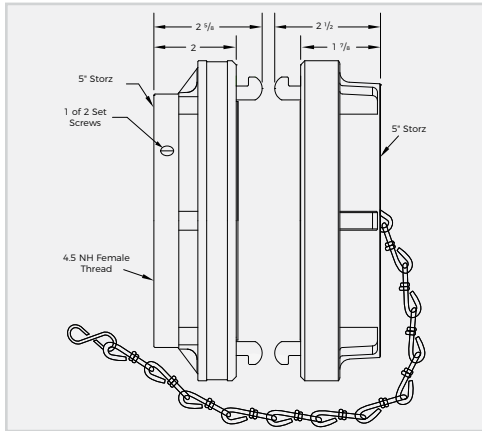

SZMC5045-2

Hardcoat Combination



Cover Color Options



Also available in Micralox, Quantum and Powder Coat options.

KEY FEATURES:

- Aluminum Alloy 6061-T6 extruded forging only.
- (2) Stainless steel set screws for mounting.
- Set screws must be mounted 180 degrees apart.
- The converter is hard anodized aluminum metal face seal and hard anodized aluminum Storz ramp and lugs.
- The NH thread female adapter contains a flat rubber gasket which seals against the male hydrant nozzle.
- The high torque, anti theft cap requires a Storz wrench for removal.

CAP CONSTRUCTION:

ASSEMBLY Both the center cap and the outer assembly containing the Storz ramps and lugs is Aluminum alloy 6061-T6 forged extrusion only. Cap is equipped with a chain. Once installed, the Storz Hydrant Converter with cap extends less than 3" from the hydrant nozzle.

CABLE 3/32", (7 x 7) Stainless steel aircraft cable w/ stainless steel eyelet end is supplied with the cap.

GASKETS Commercial grade neoprene & molded SBR rubber

SCREWS 304 stainless steel socket head screws



09K25225M



09KT25225M

Gate Valve 2.5 NH SW RL F x 2.5 NH M

09K GATE VALVE

Excellent shut off valve used on 2 1/2" Hydrant outlets to control water hammer and reduce hydrant main damage. Offering two styles of handles, traditional hand and crank, this valve has a lightweight, durable aluminum body construction which is powder coated for corrosion resistance.

Available LDH Gate Valves



KEY FEATURES:

- Non rising stem with crank
- Metal to metal seat
- Ideal for use in hose testing and on hydrants, stand pipes and pumps.

Maximum Operating Pressure	Weight (lbs.)	Length (inches)
300 PSI	4.2	13 x 5.25 x 5.25

Less than nine turns to open and close.

26K 2-WAY BALL VALVE

The Kochek **2-Way Ball Valve** is used for splitting a single water supply when two are desired on a fire scene. Valve can be installed between hose lays, on fire hydrants, trucks or standpipes.

Part Number	Working Pressure	Weight (lbs.)	Length (inches)	Width (inches)	Height (inches)
26K1525	200 PSI	4.1	5.5	9.125	4.5

Material: Cast Aluminum **Color:** Red & Black



26K 2-Way Ball Valve in use.

Available LDH Ball Valves



21K



23K



70K PISTON INTAKE VALVE

A compact, lightweight, powder coated aluminum body piston valve with a 45 degree valve. Corrosion resistant brass piston and designed for maximum flows.

Weight (lbs.)	Height (inches)	Width (inches)	Extends (inches)
25	16 ³ / ₄	7 ³ / ₄	10 ¹ / ₄
Friction Loss: 6 PSI at 1,500 GPM; 10 PSI at 2,000 GPM			

KEY FEATURES:

- Highly corrosion resistant chrome-plated brass internal piston.
- Large turbulence reducing oval waterway for minimal friction loss.
- Forged storz head with stainless steel locking mechanism.
- Pressure relief valve allows for easy adjustments from 75-250 PSI in increments of 25 with round 2 5/8" dump.
- Extends only 10 1/4" from pump panel.
- Available with full time swiveling storz heads to prevent hose kinking.

Tested per NFPA 1965

OTHER LDH APPLIANCES



32K
Manifold & Hydrassist Valve



51K
Manifold & Hydrassist Valve



80K
Manifold & Hydrassist Valve

SIAMESE VALVE

All four styles of Kochek's Siamese Valve feature an aluminum body and clapper valve. Several different configurations and valve discharge use may affect actual friction loss created in the field. The fire department should evaluate actual friction loss during training.



20K0525

20K - 2 Way-Siamese-Clappered



30K 3-Way Siamese - Clappered

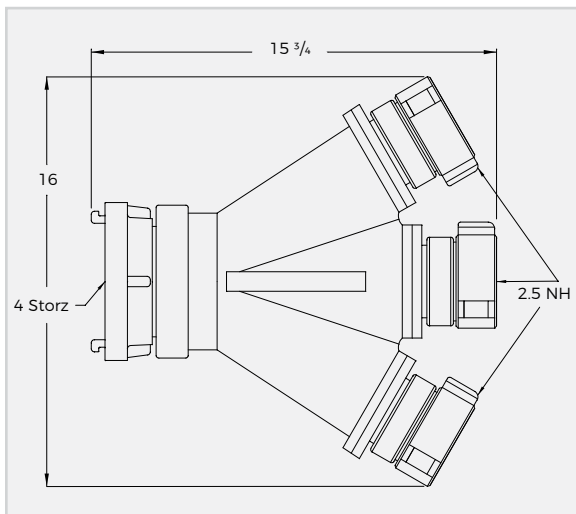
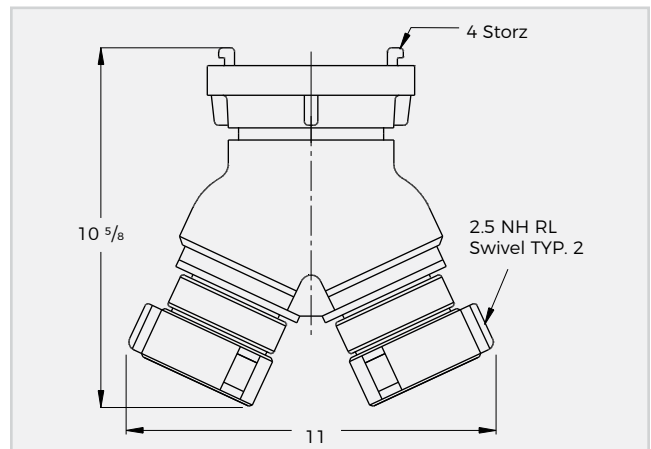

50K - Jumbo Siamese-Clappered





24K - 6" Suction Siamese



Examples of: Kochek Caps & Plugs

CAPS & PLUGS

Caps		
		
CC Storz Cap with Chain	CC Hydrant Storz Cap with Cable	CC 201 Deep Throat Storz Cap with Chain
		
CC Cap Gauge	CC Camlock Cap with Chain	CC or CP British Instantaneous Cap

Plugs

PL or PC Plug

PC Camlock Plug with Chain

PL or PC British Instantaneous Plug



Examples of: Micralox and Quantum Hardcoat Color
Other Colors Available

KOCHEK ADAPTERS

Kochek offers a variety of adapters. They are available in a variety of configurations such as rocker lug, long handle, rigid, swivel, storz and special thread. They come in a many sizes and different finishes. The adapter lines meet or exceed all NFPA Standards.

FINISHES:

K-COAT Tough, durable powder coating that is non conductive to help inhibit electrolysis, color consistent to delta 0.5, and available in many vivid colors.

NATURAL HARDCOAT High quality durable finish that is most often specified by manufacturing engineers. Satin finish meeting Mil Spec 8625 Type III Class I.

GASKETS High quality, durable finish that is most often specified by manufacturing engineers. Satin finish that meets Mil Spec 8625 Type III Class I.

QUANTUM® Vibrant anodized color, attractive, versatile, durable, even coverage, meets Mil Spec 8625 Type III Class II.

MICRALOX® A patented micro-crystalline anodizing process, offering long lasting colorized color hardcoat that offers superior resistance to abrasion and chemical corrosion. It extends the life of aluminum parts up to 10 times compared to conventional aluminum anodic coatings having withstood 15,000 hours of salt spray with no pitting. Ideal for harsh environments, coastal areas, marine applications or roadways where salt corrosion is a concern. Meets Mil Spec 8625 Type III Class II.

Threaded Adapters



Storz Adapters



All adaptors are available in all finishes.

THREADED ELBOWS

Threaded Elbow Options



KE-R 30° Elbow SW RL Female to Male Threads SW RL F X M 30° Elbow



KE-L 30° Elbow SW LH Female to Male Threads SW RL F X M 30° Elbow



HPKE-R & RC 45° Elbow SW RL Female to Male Threads 45° High Pressure Elbow

STORZ ELBOWS

Storz Elbow Options



SKE-R 30° Elbow Swivel Rocker Lug Female to Storz



SKE-TR 30° Elbow Full time Swivel Storz to Rocker Lug Female



SKE-L 30° Elbow Swivel Long Handle Female to Storz



SKE-TL 30° Full time SW Storz to SW LH Female

SUCTION ELBOWS



KEP-R SW RL Female to Male

HIGH PRESSURE ELBOWS

High Pressure Elbow Options



HPKE25R2590
K-Coat



HPKE25R2590-Y
Powder Coat

FLANGE STYLES & OPTIONS

Kochek flanges are made from carbon steel and can be used by in a variety of industries, including: firefighting, waste water & water management and industrial applications. They're a great way to designate proper hook up.



Flange X Male

Flange X Camlock



Flange X Storz



Flange X RL F SW



Flange X Groove

Our powder coat finish offers a broad selection in color

					
Robin's Egg	Dark Blue	Lavender	Evergreen	Silver Fern	Purple
					
Fire Engine Red	Light Burgandy	Silvadillo	Yellow/ Lime	Safety Yellow	Safety Orange
					
Sky White	Almond	Black Wrinkle	Lucy Brown	Bronze	Black

LAZER ENGRAVING:



Custom laser engraving of company's names and logos